



## International Journal of Control Theory and Applications

ISSN : 0974-5572

© International Science Press

Volume 10 • Number 22 • 2017

### PO-SEAT Design for Medicare Applications

Chennapanaidu Harshitha<sup>1</sup>, Krishna Chennakesava Rao M.<sup>1</sup> and Ketankumar Vadodaria<sup>2</sup>

<sup>1</sup> Department of Electronics and communication engineering, VFSTR University, India, E-mail: harshithasindhuc@gmail.com

<sup>2</sup> SITRA, Medical Textile - COE

**Abstract:** Due to recent developments in wireless medical care communication and electronics industry leads to wide variety of real time applications. Introduction of small scale embedded processors and flexible systems have provided a new path for mobile communication and constant interaction from day to day life. Detection of sitting posture and monitoring can be analysed by PO-SEAT. It is a smart cushion which is deployed for prevention of back pain. The important cause for back pain is due to the improper sitting posture and position. The po-seat can hook on to the cushion which will collect various types of signals from the user's sitting position, temperature, and duration of time and send the data to person's mobile phone and also displayed on the LCD screen. The users sitting position and leaning direction such as leaning left, right, forward, backward, straight can be continuously monitored and detected, if the value exceeds the threshold limit, alert is sent to person's portable device. The vibration strength of the seat can be known by three axis acceleration sensor, With the help of six force sensitive resistors the posture can be analysed and message alert is sent to user's mobile phone using GSM communication and displayed on LCD Screen. This system is efficient and provides real time monitoring which has a great future scope.

**Keywords:** PO-SEAT, Cushion, Posture, Arduino, Force sensitive resistor.

#### 1. INTRODUCTION

Due to recent developments in wireless medical care communication and electronics industry leads to a wide variety of real time applications. Introduction of small scale embedded processors and flexible systems have provided a new path for mobile communication and constant interaction from day to day life. There exists a lot of changes in the living environment and lifestyle of a person which provides a lot of improved services with a combination of information technologies and embedded processors. Sitting is the most important action in daily life, such as in offices, schools, hospitals and work places with HCI (Human Computer Interface). Sitting posture in constant angle leads to adverse effects to health and tends to back pain.

#### Improper seated posture can have effects on back pain

- (1) A person involved in offices, classrooms, home etc.
- (2) Farmers during tractors and truck driving.

(3) Pilot's during driving aircrafts.

- Now a day working place is complete with HCI, an average person spends more than 50,000 hours in sitting position in his work life. Due to inimical effects 40% of office working people face back problems.<sup>1</sup>
- Experiencing back pain is common in the occupations such as driving a tractor and truck. It involves exposure of vibration to the whole body and twisting of the spinal cord. Long exposure of these increases health risks.<sup>2</sup>
- Back pain may be caused due to vibration of aircraft, the posture of the pilot during aircraft control, muscle fatigue of pilot and improper construction of cushion.<sup>3</sup>

These are the few cases in the real time world which experiences the effects of back pain these can be prevented by the development of a POSEAT. When cervical, thoracic, lumbar, sacrum and coccyx vertebrae get affected, leading to back pain, if pain exceeds more than a limit it becomes chronic. Types of back pains are low back pain, transient low back pain, chronic low back pain, sciatic pain, acute low back pain. According to the survey and doctors' reports says that constant posture without any moments influences back pain.

### **Causes for back pain include**

- Sitting characteristics of human beings.
- Seat positions.
- Vibration of seat, posture and workload

When the person is at work he doesn't concern about their body positions, sitting characteristics and seat positions like left leaning, right leaning, backward leaning, constant sitting, and frontward leaning more than the certain duration leads to changes in the spine vertebrae.

- Vibration strength of the seat influences a lot. Resonant frequency in the spinal system which leads to unnecessary disturbance's and discomfort to the person.
- Improper sitting posture will straighten the normal curved spine and pressure will be increased
- The posture of the person and workload involved, stress is also considerable factors.

One best way to prevent back pain is by having your muscles strong and by proper exercise, here we implement a cushion cover which involves sensors and processors which determine the posture of the person during sitting and intimates the person. So prevention can be possible and it is flexible without causing any discomfort to the person.

## **2. DEVELOPMENT OF POSEAT**

Here we developed a PoSeat. It is a smart cushion cover which prevents the back pain. It is a new way which gives detection and prevention. It recognizes the posture of the person. It consists of six force sensitive resistors to measure the amount of pressure exerted by the person on the cushion. Here number of force sensitive resistors can be increased, but to determine the posture six sensors which are 5 inches are sufficient. A three axis acceleration sensor is used to determine the vibration strength of the seat when the person is at the risk of back pains

Important features of this cushion cover:

1. It is cheaper and easily developed with low cost sensors when compared to buying an advanced chair.
2. It is portable.
3. Smart posture detection and prevention of back pain
4. More flexible and convenient ease of communication with mobile phone.

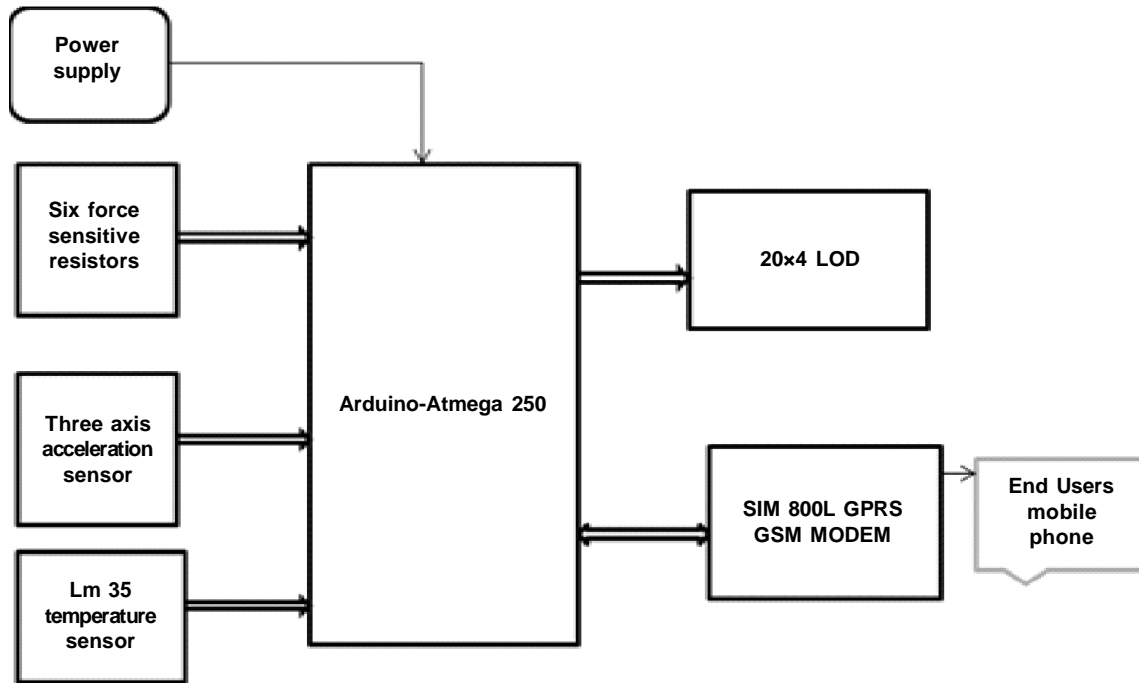

Figure 1: Block diagram of PoSeat implementation

1. The Force Sensitive Resistor (FSR)<sup>9</sup> used here is of 0.5" diameter, depending on the amount of pressure applied to the area which is to be sensed the resistance will be varied. If there is more the amount of force there will be low resistance. Whenever no force is exerted on the FSR, it will vary more than 1M $\Omega$ .



Figure 2: Force Sensitive Resistor

2. The accelerometer used is ADXL335 Three axis acceleration sensor which will read x, y and z acceleration and is very easy to interface with the Arduino micro controller. Accelerometers measure the acceleration due to the gravity and find the tilted angle with reference to the earth. Dynamic acceleration and static acceleration can be measured. The static acceleration can be obtained in tilt sensing applications, whereas dynamic acceleration can be known by vibration, motion, and shock and by this it can find out how fast the device moves and the direction of the moving device.

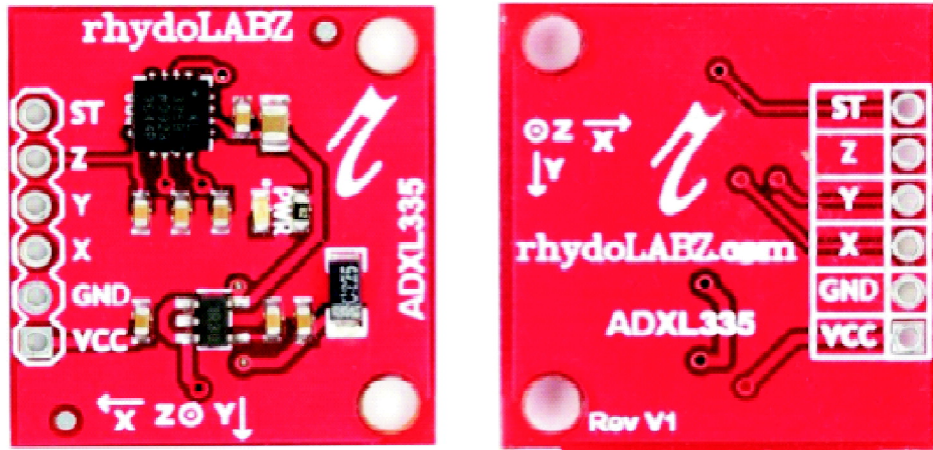

Figure 3: ADXL335 Three axis acceleration sensor

3. An ideal temperature sensor is LM35 is used to measure ambient temperature, it has linear output. The LM35 can be easily interfaced with Arduino and it does not require any signal conditioning because they have linear characteristics. Instead of thermocouple and Thermistors these are easy to use.
4. Arduino – Atmega 2560<sup>8</sup> has 16 analog inputs, 54 digital input and output pins, 4 hardware serial ports (UARTS), crystal oscillator of 16MHZ, power button along with USB connection, ICSP header and reset button. The operating voltage is 5v flash memory of 256 KB in which 8KB is used by the boot loader. It is an open source. Programing can be written in c or c++.

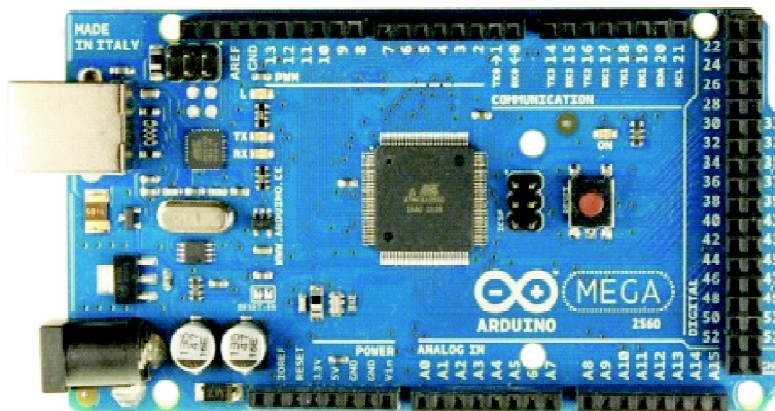

Figure 4: Arduino-Atmega 2560

5. A 20 character by 4 line display is used. It uses parallel interface chip set data. In order to interface with LCD Screen 11 general input, output pins are required.  
A SIM800L GPRS, GSM Modem is used, the unique features of GPRS include wide coverage, GPRS activated services as long as online, high speed transmission peak transfer rate of 85.6Kbps
6. This module supports 900MHZ band. The GSM module can be directly connected with the Arduino because it is inbuilt enabled with TTL pins. If not present we have to convert RS232 data to TTL data using MAX232 cable which is a level convertor.

In general, most common painful areas include 36% for shoulders and 63% of low back pain, 52% for neck due to improper postures.

Sitting angle of 110°- 130° is optimal for spine comfort.

Leaning back angle of 135° is ideal for back pain prevention.

Here we can add extra features like providing alerts to the user like drink water rotate head, walk for a minute. To identify 10 real time postures a sample input should be taken tested and the received is transmitted as the input of the recognizer.

It includes:

- Understanding the values obtained by the Force sensitive resistors and
- Posture information



Figure 5: General sitting posture

Table 1  
Posture types and their angles

Type of posture	Abbreviation	Threshold Angle
Leaning left	LL	75°
Leaning right	LR	290°
Leaning backward	LB	135°
Leaning forward	LF	0° or 360°
Leaning left forward	LLF	60°
Leaning right forward	LRF	310°
Leaning left backward	LLB	140°
Leaning right backward	LRB	240°
Straight sitting	SS	110°
No one sitting	N	NA



### 3. SYSTEM ANALYSIS

The electronic components attached to the PoSeat (cushion cover) performs pre-processing and signal conditioning provides complete analysis.

The six FSR (Force sensitive resistors) is used, four sensors are placed at the back side of the cushion and two sensors are placed on the bottom side of the cushion. The sensor data is sent continuously to the Arduino board. The six sensor data is collected from the FSRs and given to Arduino module, here no need of analog to digital convertor because the Arduino module has analog input pins and its converts into digital data.

It works based on the power supply of 3.3v CMOS battery can last for a week without any power management techniques. The three axis acceleration sensor is kept at the back of the cushion cover, the vibration strength can be known by change in frequency from the accelerometer reading, and the leaning angle of the cushion can be obtained based on the back four FSR sensors and accelerometer.

1. Both sensed data from 1 and 2 are received by Atmega- 2560 Arduino module; it can be powered with the help of a USB cable and program written with c or c++ due its advantage of open source.
2. The leaning angles and alert are displayed on the LCD screen and communicates with the end user with GSM mode of communication to the prescribed mobile number.

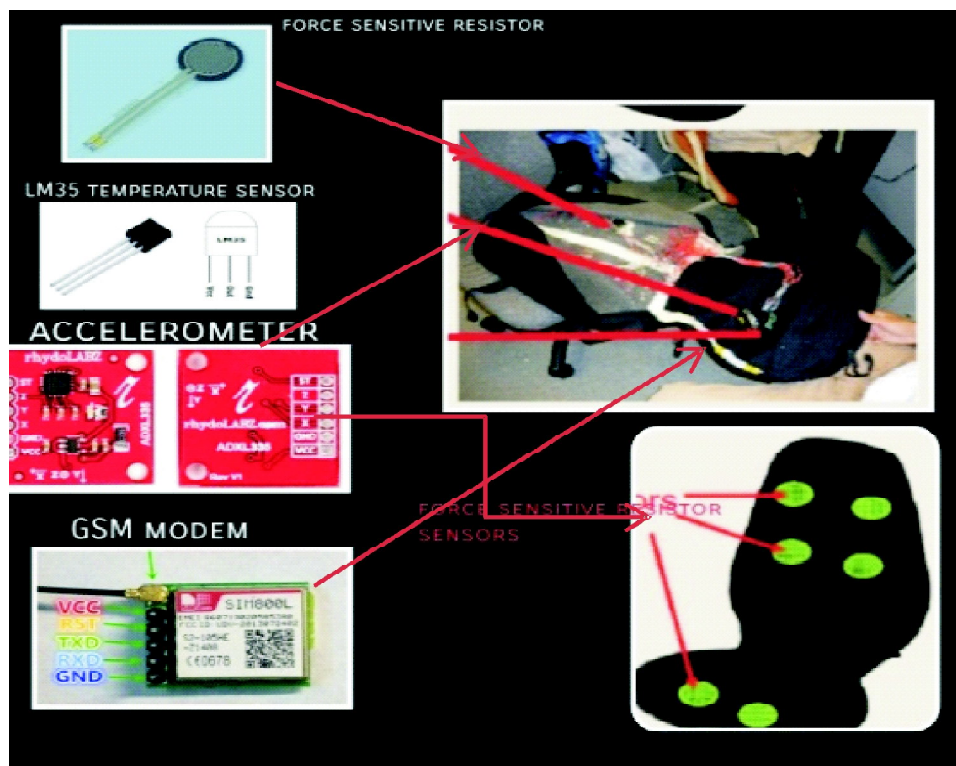

Figure 6: Assembling of hardware

### 4. EXPERIMENTS AND RESULTS

The aim of this paper is to obtain the sitting posture indications, amount of force applied and temperature in the form of warning message to the end user using GSM so that it can be a prevention for back pain. This paper also suggests proper actions like drinking water, rotate head, walk for a while can be performed such that necessary Medicare can be provided. When the user sits on this PoSeat cushion cover, the Following results are obtained

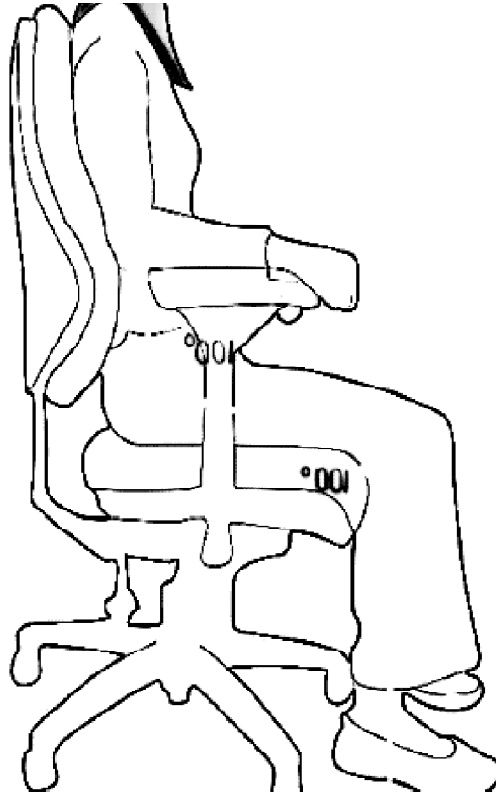
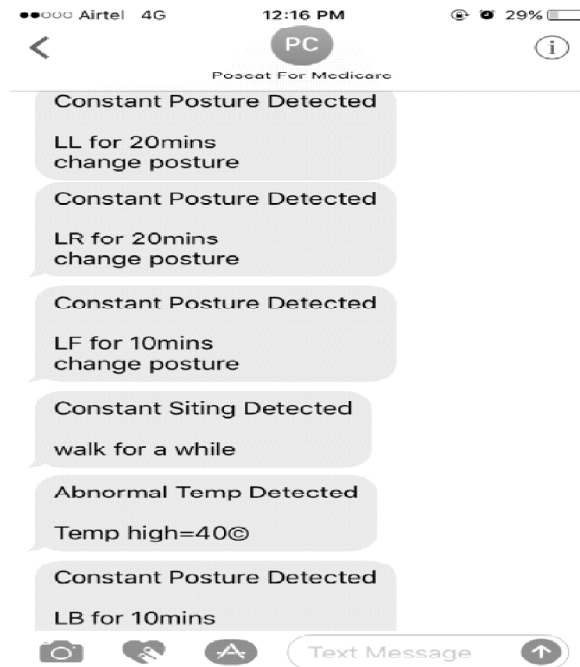
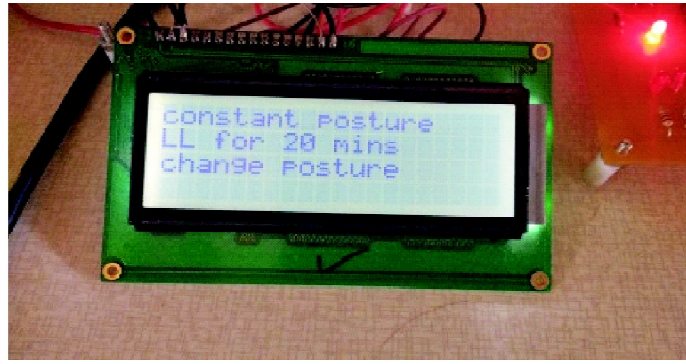
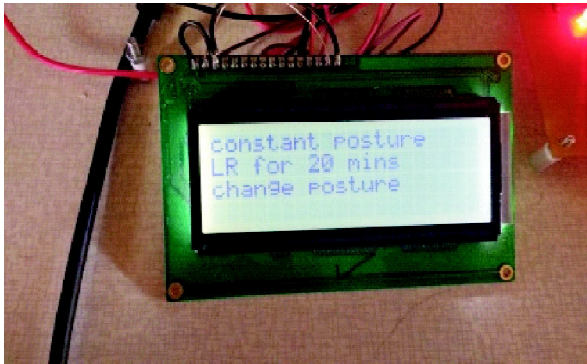

Figure 7: Person sitting on chair

As shown in fig. 7, when a user sits on the chair the following images shows the obtained results. And provides alert to the user to change the posture and to change normal activities.



Result 1: User alert with GSM communication



**Result 2: Posture alert messages displayed on LCD screen**

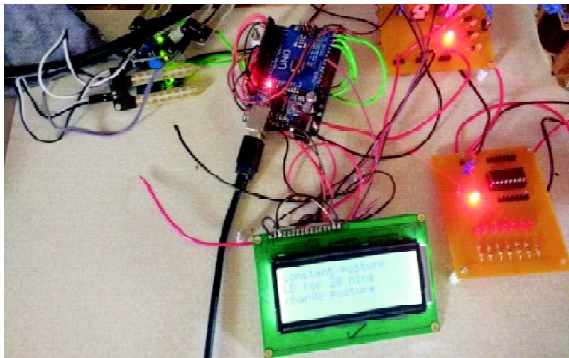

## 5. CONCLUSION

Here we presented a wireless Medicare application PoSeat cushion cover which will prevent the back pain issues based on the sensing and recognizing of sitting posture of the person. Our deployed system is highly cost effective and portable and easy operate and also reducing development of hardware cost. The designed system has lot of future scope with the use of Nano sensors, MEMS sensors and hetro core fiber optic sensors have greater flexibility.

## REFERENCES

- [1] M. Ertel, G. Junghanns, E. Pech, and P.Ullsperger. Effects of vdu-assisted work on health and well-being. Research Report 762, Federal Institute for Occupational safety and Health(BauA), 1997.
- [2] Sheila Scutter”The effects of an air-filled cushion on back pain experienced by farmers driving tractors,”6<sup>th</sup> National Rural Health Conference.
- [3] Yu Hu, Stoelting A., Yi- Tao Wang, Yi Zou and Sarrafzadeh M., “Providing a cushion for wireless healthcare application development,” Potentials, IEEE, vol.29, no.1, pp.19-23, Jan.-Feb.2010.
- [4] Yue Li and Aissaoui R., “Smart Sensor, Smart Chair, Can it predicts Your Sitting Posture?” Industrial Electronics, 2006 IEEE International Symposium on, vol.4, pp.2754-2759, 9-13 July 2006.
- [5] Wenyao Xu, Zhinan Li, Ming-Chun Huang, Amini N. and Sarrafzadeh M., “ecushion: An eTextile Device for Sitting Posture Monitoring,” Body Sensor Networks (BSN), 2011 International Conference on, pp.194-199, 23-25 May 2011
- [6] Lishuang Xu, Gang Chen, Jiajun Wang, Ruimin Shen Zhao, “A Sensing Cushion Using Simple Pressure Distribution Sensors”2012 IEEE International Conference on Multisensor Fusion and Integration for Intelligent Systems(MFI)September 13-15,2012. Hamburg, Germany
- [7] JanMeyer, Bert Arrrich, Johannes Schumm, and Gerhard Troster,Design and Modeling of a Textile Pressure Sensor for Sitting Classification, IEEE Sensors Journal, vol. 10, no. 8, pp.131-1398, August 2010.
- [8] Arduino-Atmega 2560. <https://www.arduino.cc/en/Main/arduinoBoardMega2560>. Date accessed: 08/08/2016.
- [9] Force sensitive resistor, state of art pointing solutions of OEM, Version 1.0, 90-45632 Rev. D.