

## International Journal of Control Theory and Applications

ISSN : 0974-5572

© International Science Press

Volume 9 • Number 50 • 2016

### Harmonic Elimination of Seven Level Inverter with Switching Pattern Reconfiguration Technique Using Hybrid BBO/MAS Algorithm

R. Kavitha, Rani Thottungal

Department of Electrical and Electronics Engineering, Kumaraguru College of Technology

**Abstract:** A hybrid optimization algorithm is proposed in this paper to find the optimum switching angles in a Cascaded Multilevel Inverter (CMLI). A seven level cascaded inverter is considered and optimum switching angles are found by hybrid Biogeographical Based Optimization search (BBO) / Mesh Adaptive Direct Search (MAS) algorithm. The fundamental frequency Selective Harmonic Elimination-Pulse Width Modulation (SHE-PWM) technique is applied in order to reduce the switching losses. Reconfiguration technique is also proposed to achieve harmonic elimination for entire Modulation index (M). The various performance indices like phase THD, line THD, lower order harmonics eliminated in a CMLI are calculated based on the optimized switching angles. A seven level CMLI is simulated in MATLAB/SIMULINK by using switching angles calculated from BBO/MAS algorithm and the FFT analysis of traditional SHE-PWM and reconfiguration SHE-PWM methods are compared and verified with the calculated values from BBO/MAS algorithm.

**Keyword:** Cascaded Multi-level Inverter, Biogeographical Based Optimization (BBO), Modulation Index (M) Mesh Adaptive Direct Search, Selective Harmonic Elimination

#### 1. INTRODUCTION

In recent decades, the research on Multilevel Inverters (MLI) have been increasing as it becomes a viable solution for high power applications, such as large motor drives, railway traction applications, High-Voltage DC transmissions (HVDC), STATCOM and static VAR compensators [1], [2]. The output voltage of MLI has a stepped waveform. As the number of voltage level increases, there is less distortion in output voltage waveform and size of the output filter is reduced.

It is necessary to eliminate undesired low frequency harmonics in electrical power systems as it leads to power quality problems. There are several modulation techniques to control the output voltage of MLI. The drawback of using high frequency control [3] [4] is that it provides high switching losses and also lower order harmonics cannot be eliminated. The proposed CMLI employ SHE-PWM technique [5] as it is operated at fundamental switching frequency. By SHE-PWM method the switching angles are determined to eliminate the

low frequency harmonics and to maintain desired fundamental voltage [6]. In SHE-PWM the harmonic elimination is based on number of Degrees of Freedom (DOF). In case of 7-level inverter, three switching angles are controllable variables and DOF is 3.

The SHE equation is non linear transcendental and it can be solved by mathematical technique [7]. This can also be solved by various conventional iterative methods like Newton Raphson method and resultant theory. The drawback of Newton Raphson method is, it requires good guess of initial value and it consumes more time to converge.

Optimization techniques like Genetic Algorithm (GA) [8], Bacterial Foraging Algorithm (BFA) [9], Particle Swarm Optimization (PSO) [10], Teaching Learning based Algorithm (TLBO) , and Differential Evolution [11] have been proposed in literature to find optimum values of switching angles for MLI. Global search methods get trapped with local optima when the number of dimension increases. Hence the hybridization of two algorithms enhance the performance of CMLI in order to have very minimum specific lower order harmonics. In this paper, BBO/MAS optimization techniques are chosen to find optimum values by solving the nonlinear transcendental equations where the BBO is a global search method and MAS is a local search method. BBO has better global optimization ability than PSO so faster convergence rate is achieved.

## 2. CASCADED MULTILEVEL INVERTER

Among the various kinds of MLI [12], the CMLI has been receiving more attention especially in the motor drives and utility applications because it has less number of devices than other categories of MLI.

The basic structure of CMLI has several H-bridges connected in series with separate DC source [13]. The output voltage of CMLI is sum of voltages across each bridge as in (1). The advantage of CMLI is, the output voltage level can be increased by connecting an additional H-bridge with S number of DC sources. The N output levels generated by S H-bridge cell is given by  $N = 2S + 1$ , where S is the number of DC sources. Therefore to synthesize seven-level, three H-bridges with separate DC sources are required which is shown in Figure 1.

$$V_o = V_{o1} + V_{o2} + V_{o3}$$

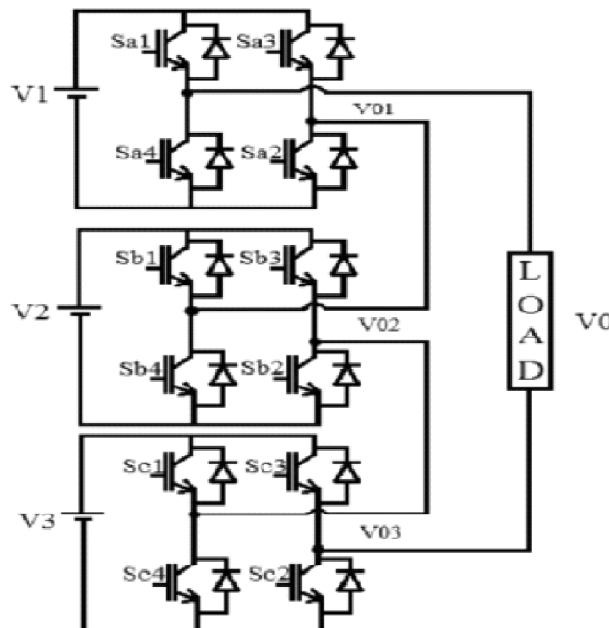

Figure 1: Cascaded Seven Level Inverter

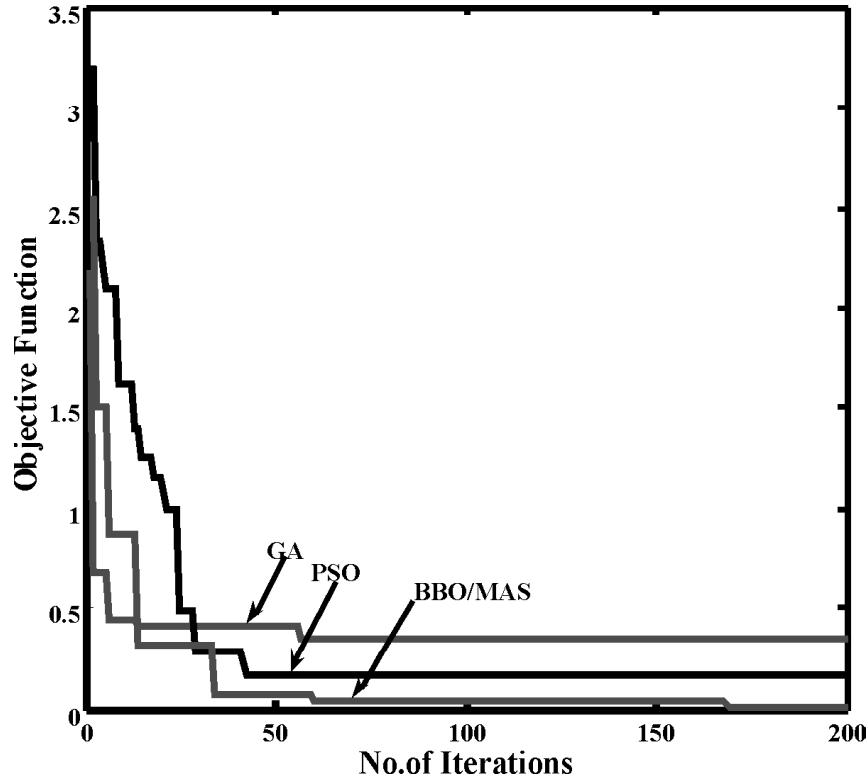

Figure 2: Convergence Plot of BBO/MAS, PSO, GA

### 3. SHE-PWM METHOD

#### Fourier Analysis of Seven Level inverter

The output waveform of MLI obeys quarter wave symmetry. By Fourier analysis, the voltage amplitude of fundamental and harmonic voltages is given by the (2). In balanced three phase system, triplen harmonics in the line-to-line voltage automatically cancel each other. Therefore for an m-level MLI, S-1 odd non-triplen harmonics are eliminated. In the case of a seven-level inverter, h5, h7 are the two odd non-triplen harmonics that are desired to be eliminated. Further higher order harmonics can be easily eliminated by using passive filter.

$$\frac{4V_{dc}}{3\pi}(\cos\theta_1 + \cos\theta_2 + \cos\theta_3) = V_{hn} \quad (2)$$

where  $V_{hn}$  is the amplitude of the harmonic term of order n.

$V_{dc}$  is amplitude DC source across each bridge, n is odd harmonic order

The objective function of SHE-PWM method is shown in (3) which has given more priority to its fundamental component with relatively moderate priority has given to the harmonics that are to be eliminated. The optimized switching angles should minimize the objective function.

$$f = \min \left\{ \left( 100 \frac{v_1^* - v_1}{v_1^*} \right) + \sum_{n=5,7}^S \frac{1}{n} \left( 50 \frac{V_{hn}}{v_1} \right)^2 \right\} \quad (3)$$

Subject to  $\theta_1 \leq \theta_2 \leq \theta_3 \leq \pi/2$

Where the fundamental voltage  $V_1 = V_{h1}$   
 $V_1^*$  is the desired fundamental voltage

## 4. HYBRID BBO/MAS OPTIMIZATION TECHNIQUE

### 4.1. Introduction of BBO/MAS Optimization Techniques

Biogeography Based Optimization (BBO) deals with the study of the distribution of species from one island to another [14]. The features like rainfall, vegetation, climate are characterize habitability are called Suitability index variables (SIV). Habitat suitability index (HSI) indicates the best region for the species to survive which is based on SIV. The emigration rate ( $\mu$ ) and immigration rate ( $\lambda$ ) are used to determine best region for immigration and emigration to improve the poor solution having low HSI. Mutation is performed to prevent the solution from trapping into local minimum.

MAS is a local search algorithm. MAS searches around the point which is calculated from the previous stage of algorithm i.e. current point and creates a set of points called mesh which is formed by adding set of vectors called patterns to the current point. The comparison of optimization techniques like BBO/MAS, PSO, GA is shown in the Figure 2 which proved that the BBO/MAS have achieved minimum objective function.

### 4.2. Algorithm of Hybrid BBO/MAS Optimization Technique

- Step 1: Initialize the parameters of BBO such as No.of Habitats, Probability of Modification, Probability of Mutation, No. of iterations  $I_{max}$ ,  $E_{max}$ , Immigration rate ( $\lambda$ ), Emigration rate ( $\mu$ ).
- Step 2: Initialize the Switching angles with boundary constraint  $\theta_1 \leq \theta_2 \leq \theta_3 \leq \pi/2$
- Step 3: The objective function of SHE-PWM as in (3) is calculated for each habitat set.
- Step 4: The habitats are sorted based on minimum value of objective function and elite habitats are kept without modification.
- Step 5: Perform the migration operation on the SIV of every non-elite Habitats.
- Step 6: Upload the species count.
- Step 7: Perform the mutation operation on non-elite Habitats. The selected habitat set is replaced by random habitat set.
- Step 8: Proceed with the step3 for the next iteration and the loop continues for given number of iterations. The optimum switching angles found by BBO algorithm are then applied to MAS algorithm.
- Step 9: Initialize a random variable  $X_0$  as current point with the optimum values obtained by BBO algorithm.
- Step 10: Create the mesh points in random and evaluate the objective function and find minimum value.
- Step 11: If the objective function has minimum value, then previous mesh size is reduced .Proceed with the step9 for the next iteration.
- Step 12: If the objective size is maximum than previous value, then the mesh size is doubled and proceeds with step9 for next iteration.

## 5. ANALYSIS OF SHE-PWM METHOD FOR A SEVEN LEVEL INVERTER

The performance indices of seven level inverter like optimized switching angles, phase THD (%), harmonics eliminated are calculated for all M by hybrid BBO/MAS algorithm in MATLAB. The switching angles are feasible for range of M from 1 to 0.5 and desired fundamental voltage is achieved. Because one or two switching

angles of seven level inverter are converging to  $90^\circ$  for  $M$  below 0.5. Thus SHE-PWM technique does not provide solution for  $M$  below 0.5 as the switching angles do not satisfy its constraint.

### 6. PROPOSED RECONFIGURATION SHE-PWM METHOD

To achieve harmonic elimination for wide range of  $M$ , reconfigured switching pattern [15] is proposed. The range of modulation indices can be divided into sectors based on number of switching angles. In seven level inverter as there are three switching angles, the modulation indices can be divided into three sectors i.e., high range (1 to 0.67), middle range (0.66 to 0.34), and low range (0.33 to 0.1).

The switching pattern of seven level waveform will be replaced by Figure 3(b) to achieve harmonic elimination for middle range of  $M$ . For Low range of  $M$ , the output waveform will be replaced by Figure 3(c). For reconfiguration method, the fundamental component amplitude and harmonics voltage amplitude are expressed by changing the polarity of cosine terms in voltage equation as in (4). In (4) rising and falling edge of reconfigured switching pattern is represented as positive and negative sign.

$$\frac{4V_{dc}}{3\pi}(\cos\theta_1 \pm \cos\theta_2 \pm \cos\theta_3) = V_{hm} \tag{4}$$

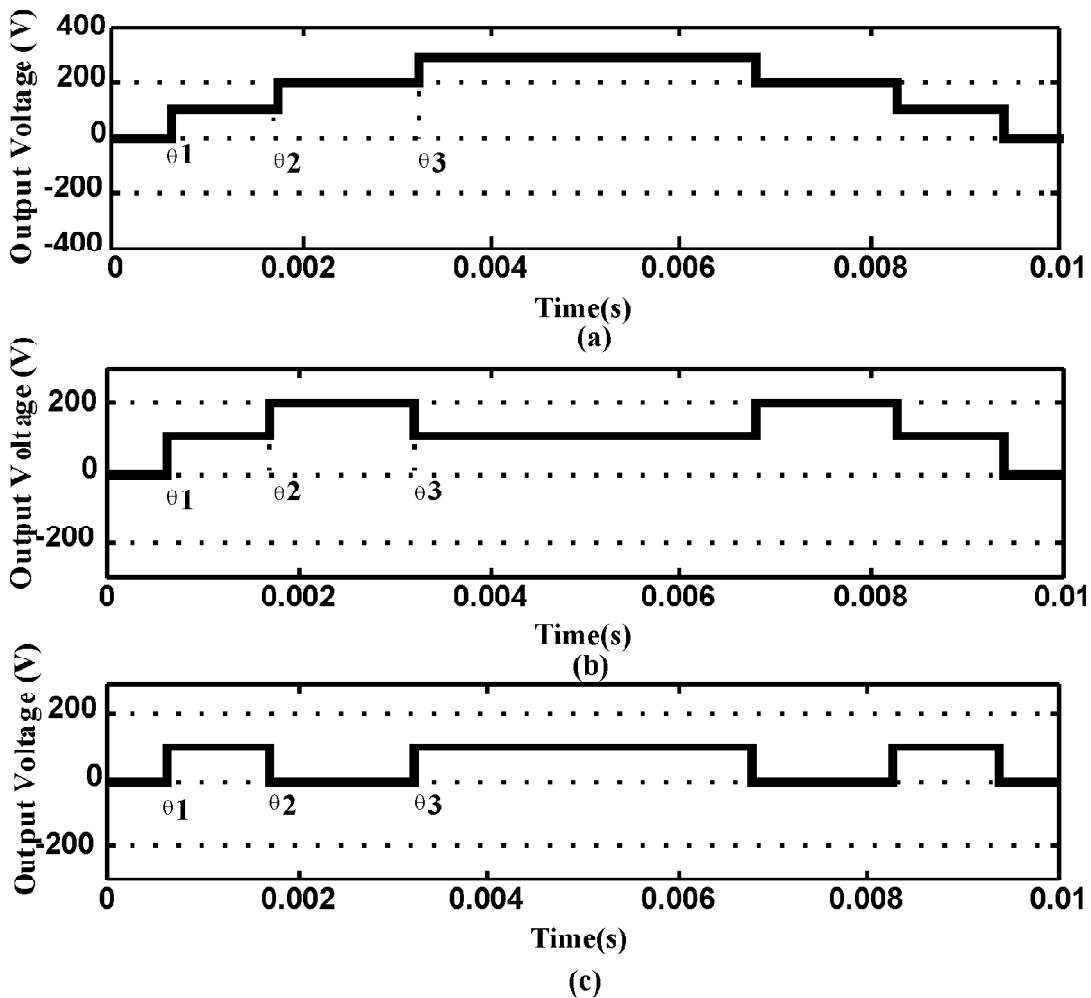

Figure 3: Reconfiguration Switching Pattern SHE-PWM (a)High Range M (b) Middle Range M (c) Low Range M

## 7. RESULTS AND DISCUSSION OF RECONFIGURATION SHE-PWM METHOD

### 7.1. Simulation Results

The performance indices of seven level inverter with traditional and reconfiguration SHE-PWM method are tabulated for each category of M as in Table 1. Unlike traditional Method, the switching angles are not converging to 90°. The control over the harmonics is improved than traditional SHE-PWM method.

**Table 1**  
Tabulation of Performance Indices of Seven Level Inverter for both Methods

SHE-PWM METHOD	M	$\theta_1$	$\theta_2$	$\theta_3$	$V_1$	THD%	SHE%
TRADITIONAL	1	11.68	31.18	58.58	3.00	12.79	4.34E-05
RECONFIGURATION	1	11.68	31.18	58.58	3.00	12.79	4.34E-05
TRADITIONAL	0.4	46.32	75.52	90.00	1.20	58.90	9.63
RECONFIGURATION	0.4	44.15	74.56	87.70	1.20	50.54	1.03
TRADITIONAL	0.2	62.3	90	90	0.60	86.53	35.21
RECONFIGURATION	0.2	50.96	63.70	73.41	0.60	88.61	1.67

Phase THD (%) of traditional and reconfiguration SHE –PWM Method is compared in the Figure 4 for various range of M. It is clearly understood that THD (%) for the range of M from 0.66 to 0.2 is improved than traditional SHE-PWM method. For the range of M below 0.2 eventhough phase THD (%) is slightly higher than the traditional SHE- PWM method, the lower harmonic profile is improved. Figure 5 clearly represent the improvement of selective individual harmonics by using reconfiguration method.

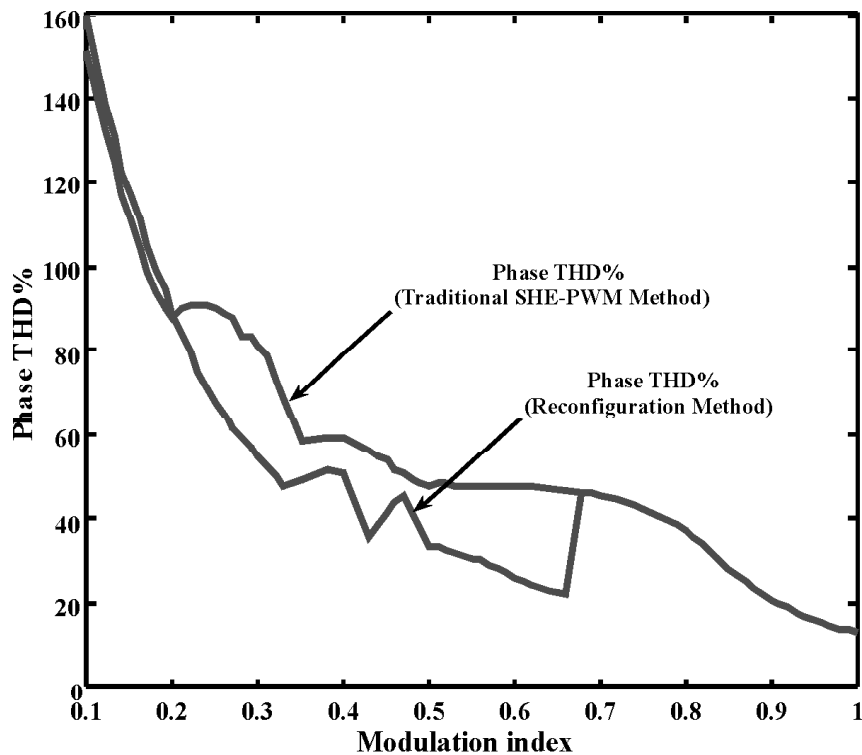

Figure 4: M Vs Phase THD%

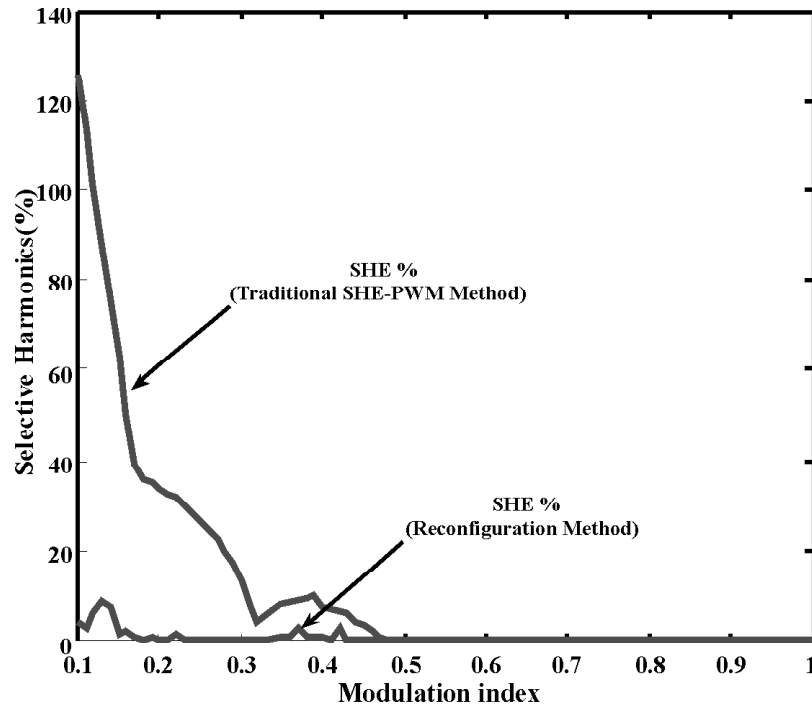

Figure 5: M Vs SHE %

### 6.2. Comparison of Traditional She-PWM and Reconfiguration Method

A 7-level CMLI is designed with 300V DC in the ratio of 1:1:1 in MATLAB/SIMULINK. The CMLI is then simulated by applying switching angles found by BBO/MAS algorithm for both traditional and reconfiguration SHE-PWM method. FFT analysis of both method are compared for each category of modulation index. The phase voltage and harmonic spectrum of both methods are shown in the Figure 6 for M=1. Fundamental component is nearer to 300V at fundamental frequency with THD 12.27%. The h5% and h7% are below 1%.

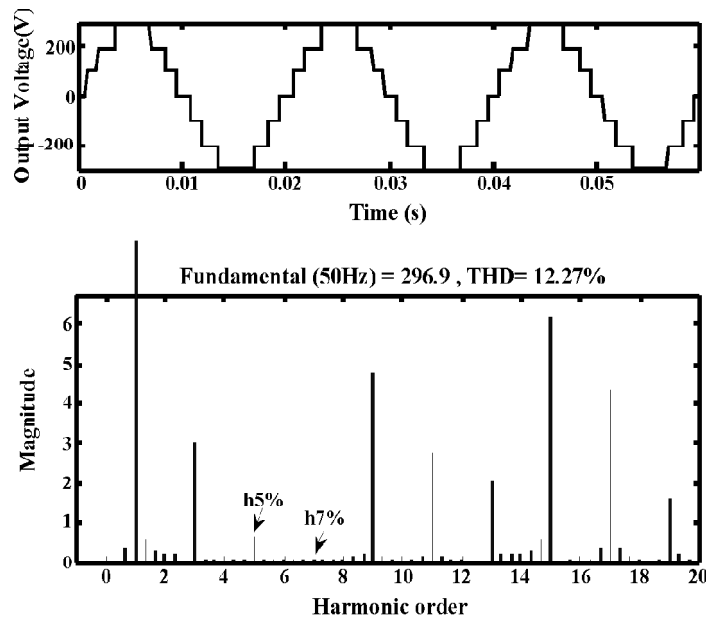

Figure 6: FFT Analysis for M=1

In case of  $M=0.4$  the output voltage level is reduced to 5 level in SHE-PWM method as in Figure 7(a). In Figure 7(b), reconfiguration switching pattern is shown and fundamental voltage is nearer to 120V. In traditional method for  $M=0.4$  the THD is 58.34%,  $h5\%$   $h7\%$  are below 10% but in reconfiguration method the THD% is reduced to 55.41% ,  $h5\%$  and  $h7\%$  are below 2% with complete elimination of lower order harmonics. The reconfiguration SHE-PWM completely eliminates  $h5\%$  and  $h7\%$  as shown in Figure 8 for  $M=0.2$ .

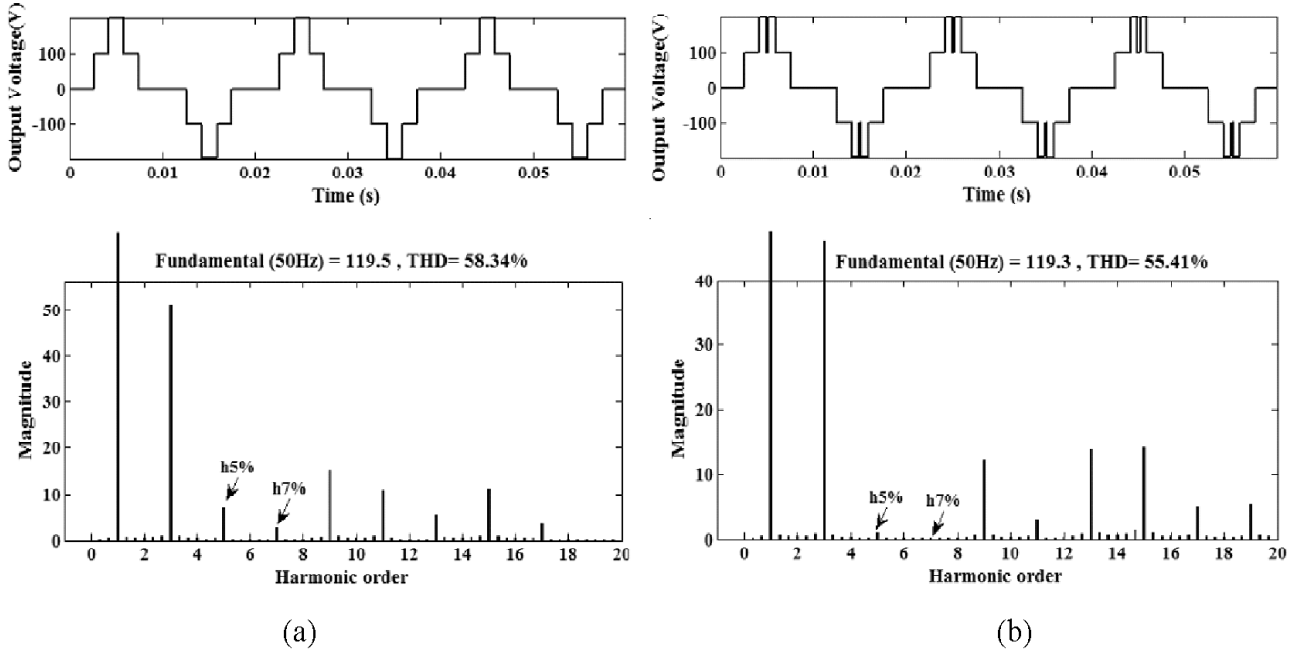

Figure 7: FFT Analysis for  $M=0.4$  (a) Traditional SHE-PWM Method (b) Reconfiguration SHE-PWM Method

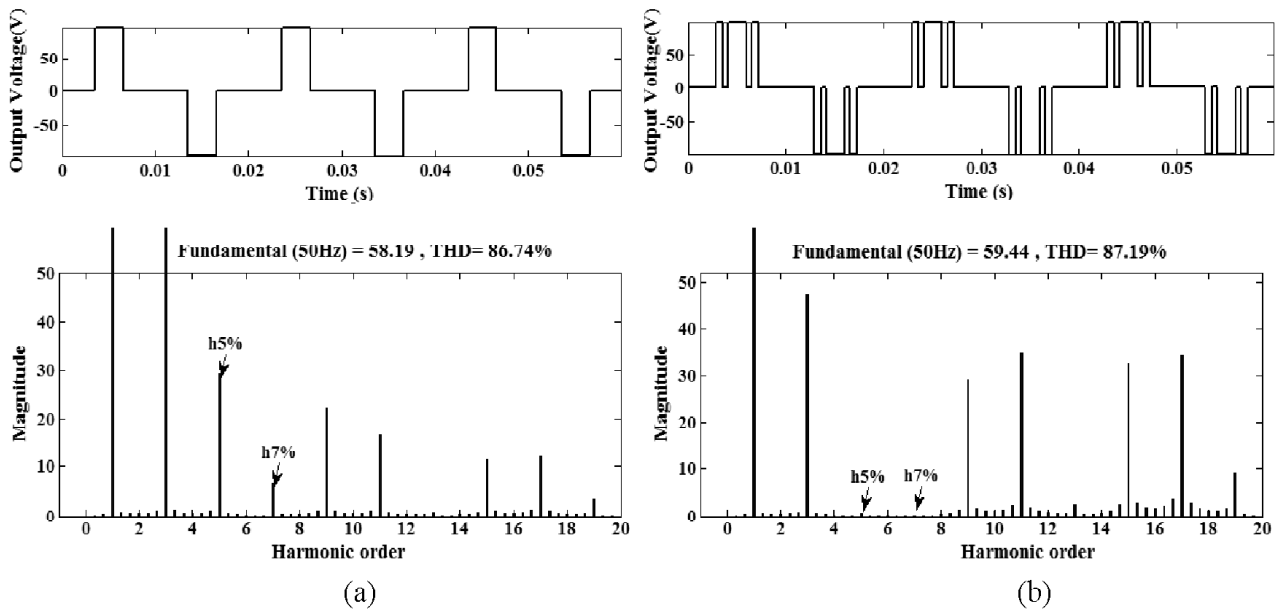

Figure 8: FFT Analysis for  $M=0.2$  (a) Traditional SHE-PWM Method (b) Reconfiguration SHE-PWM Method



## 8. CONCLUSION

Thus a novel Hybrid algorithm is proposed to improve the performance of seven-level cascaded multilevel inverter. The hybrid BBO/MAS algorithm was proven to have better convergence rate than PSO. Reconfigured switching pattern is proposed to achieve harmonic elimination for wide range of M. The simulated waveforms for both SHE-PWM and reconfiguration SHE-PWM method are compared. The reconfiguration method enhance the performance and completely eliminates the specified harmonics in the entire range of modulation index.

## REFERENCES

- [1] T. A. Meynard and H. Foch, "Multi-level Choppers for High Voltage Applications," *European Power Electronics and Drives Journal*, vol. 2, no. 1, pp. 45-50, Mar. 1992.
- [2] V. S. Bharath and Gopinath Mani, "Closed Loop Analysis of Multilevel Inverter Fed Drives," *International Journal of Power Electronics and Drive System*, vol. 4, no. 3, pp. 337-342, Sep. 2014.
- [3] D. G. Holmes and T. A. Lipo, "Pulse Width Modulation for Power Converters," Piscataway, NJ: *IEEE Press*, 2003.
- [4] M. Saeedifard, H. Nikkhajoei, R. Iravani, and A. Bakshshai, "A Space Vector Modulation Approach for a Multi-Module HVDC converter system," *IEEE Transactions on Power Delivery*, vol. 22, no. 3, pp. 1643-1654, Jul. 2007.
- [5] J. N. Chiasson, L. M. Tolbert, K. J. McKenzie and Z. Du "A Complete Solution to the Harmonic Elimination Problem," *IEEE Transactions on Power Electronics*, vol. 19, pp. 491-499, Mar. 2004.
- [6] Y. Liu, H. Hong and Q. Huang, "Real-Time Calculation of Switching Angles, Minimizing THD for Multilevel Inverters with Step Modulation," *IEEE Transactions on Industrial Electronics*, vol. 56, no.2, pp.285-293, Feb.2009.
- [7] W. Fei, X. Du, and B. Wu, "A Generalized Half-Wave Symmetry SHE-PWM Formulation for Multilevel Voltage Inverters," *IEEE Transactions on Industrial Electronics*, vol. 57, no. 9, pp. 3030-3038, Sep. 2010.
- [8] K. L. Shi and H. Li, "Optimized PWM Strategy Based On Genetic Algorithms," *IEEE Transactions on Industrial Electronics*, vol. 52, no. 5, pp. 1458-1461, Oct. 2005.
- [9] D.H. Kim, A. Abraham, and J.H. Cho, "A Hybrid Genetic Algorithm And Bacterial Foraging Approach For Global Optimization" Elsevier, *An International Journal of Information Sciences*, vol. 177, no. 18, pp.3918-3937, Sep. 2007.
- [10] M.T. Hagh, H. Taghizadeh and K. Razi, "Harmonic Minimization in Multilevel Inverters Using Modified Species- Based Particle Swarm Optimization", *IEEE Transactions on Power Electronics*, vol.24, no.10, pp. 2259-2267, Oct. 2009.
- [11] Ayong Hiendro, "Multiple Switching Patterns for SHEPWM Inverters Using Differential Evolution Algorithms", *International Journal of Power Electronics and Drive System*, Vol. 1, no. 2, pp. 94-103, Dec.2011.
- [12] Muhammad Jamil, "Comparison of Multilevel Inverters for the Reduction of Common Mode Voltage," *International Journal of Power Electronics and Drive System*, Vol. 3, no. 2, pp. 170-178, Jun. 2013.
- [13] M. Malinowski, K. Gopakumar, J. Rodriguez, and M. A. Pérez, "A Survey On Cascaded Multilevel Inverters", *IEEE Transactions on Industrial Electronics*, vol. 57, no. 7, pp. 2197-2206, Jul. 2010.
- [14] D. Simon, "Biogeography-based optimization," *IEEE Transactions on Evolutionary Computation*, vol.12, no. 6, pp. 702-713, Dec. 2008.
- [15] Sirioj Sirisukprasert, Jih-Sheng Lai and Tian-Hua Liu, "Optimum Harmonic Reduction With a Wide Range of Modulation Indexes for Multilevel Converters", *IEEE Transactions on Industrial Electronics*, vol. 49, no. 4, pp. 875-881, Aug. 2002.