

Solar Photovoltaic Powered Refrigeration: A Review

M. K. Ghosal*, S. K. Mohanty, N. Sahoo and R. K. Das

Abstract: Providing cooling by utilizing renewable energy such as solar energy is a key solution to the energy and environmental issues. In recent years, scientists have increasingly paid more attention to solar energy. There is a sudden demand in the utilization of solar energy for various applications such as water heating, building heating/cooling, cooking, power generation and refrigeration. Solar refrigeration technology engages a system where solar power is used for cooling purposes. Cooling can be achieved through four basic methods: solar photovoltaic cooling, solar thermo electrical cooling, solar thermo-mechanical cooling, and solar thermal cooling. The first is a photovoltaic (PV) based solar energy system, where solar energy is converted into electrical energy and used for refrigeration much like conventional methods. Out of the above four methods of cooling, solar photovoltaic cooling is gaining more momentum now-a-days due to its easy installation, operation, absence of any thermal process, very little maintenance and long durability. The feasibility in the applications of cooling through solar photovoltaic system has therefore been discussed in this paper through the work undertaken by various researchers.

Key words: Solar cooling, Storage of horticultural produce, Renewable Energy, Solar Photovoltaic applications, Evaporative cooling.

INTRODUCTION

One of the important applications of solar refrigeration is the preservation of fruits and vegetables due to the major concern of about 30-35 % of their annual post harvest losses in the leading vegetable growing country like India. India is the second largest producer of vegetables having 9.20 million ha under vegetable crops, with a production of 162 million tones (Jain 2007). Vegetables are required to be stored at lower temperature because they are highly perishable in nature. There are many methods to cool the environment. Preserving them in their fresh form demands that the chemical, biochemical and physiological changes are restricted to as minimum as possible by close control of space temperature and humidity. The high cost involved in developing cold storage or controlled atmosphere storage is a pressing problem in several developing countries. Several simple practices are useful for

cooling and enhancing storage system efficiency wherever they are used, and especially in developing countries, where energy availability may be critical. The refrigeration and other commercial cold storage systems are the solution of the problem, but could not be fully exploited due to heavy initial cost and demand high input of energy. Mechanical refrigeration is also energy intensive and expensive, involves considerable initial capital investment, and requires uninterrupted supplies of electricity which are not always readily available, and cannot be quickly and easily installed. Available cold storage in India is used primarily for the storage of potatoes. Appropriate cool storage technologies are therefore required in India for on farm storage of fresh horticultural produce in remote and inaccessible areas, to reduce losses. The favorable environment for storage of fruits and vegetables is low

* Department of Farm Machinery and Power, College of Agricultural Engineering and Technology, O.U.A.T., Bhubaneswar-751003

Corresponding E mail: mkghosal1@rediffmail.com

temperature and high humidity due to their high moisture contents. Combination of both temperature and relative humidity to the recommended storage condition is very important to enhance the shelf life of vegetables. Recommended temperature may be achieved due to mechanical refrigeration but desired humidity cannot be maintained. Hence to maintain both the parameters, mechanical refrigeration as well as evaporative method of cooling are required.

Cooling through evaporation is an ancient and effective method of lowering temperature. Both plants and animals use this method to lower their temperatures. Trees, through the method of evapotranspiration, for example, remain cooler than their environment. The basic principle relies on cooling by evaporation. When water evaporates, it draws energy from its surroundings which produce a considerable cooling effect. Evaporative cooling occurs when air that is not too humid passes over a wet surface: the faster the rate of evaporation, the greater the cooling. The efficiency of an evaporative cooler depends on the humidity of the surrounding air. Evaporative cooling is dependent on the conditions of the air and it is necessary to determine the weather conditions that may be encountered to properly evaluate the possible effectiveness of evaporative coolers. On the other hand, the amount of water vapor that can be taken up and held by the air is not constant: it depends on two factors: the first is the temperature (energy level) of the air, which determines the potential of the air to take up and hold water vapor. The second involves the availability of water: if little or no water is present the air will be unable to take up very much. The operational effectiveness of an evaporative cooler is made up of a porous material that is fed with water. Hot dry air is drawn over the material. The water evaporates into the air raising the humidity and at the same time reducing the temperature of the air. However, required drop of temperature in the cool chamber compared to ambient condition may not be obtained in evaporative cooling method, but desired humidity may be achieved if active method of using a motor for water circulation and a fan for sucking outside air are integrated in the system.

But reliable source of power to operate such a system comprising mechanical refrigeration system and active evaporative cooler is a major constraint in rural and off-grid areas. To make the system sustainable with respect to energy independence and reliability in grid-isolated remote areas for short-term on-farm storage of vegetables, there is the necessity of a device integrating both mechanical compressor and passive or active evaporative cooling system which can be powered by an environment-friendly and renewable source of energy. Among the various renewable energy sources, application of solar energy may be a viable option because of its adequate availability in a tropical country like India. Hence, in this paper, current status of research and recent developments in solar refrigeration systems has been reviewed for their application in various sectors including storage of vegetables. For storage of vegetables, the developments of cool chambers should be such that the temperatures in the range of 10–15 °C and relative humidity from 85 to 95 % can be maintained for obtaining better performance from the device.

REVIEW OF LITERATURES

Navigant, 2006 has provided with a broad overview of the various technologies available to use solar energy for refrigeration purposes which include the solar electric, thermo-mechanical, sorption and also some newly emerging technologies. He has also compared the potential of these different technologies in delivering competitive sustainable solutions. He has discussed the possibility of using photovoltaic powered vapour compression systems; continuous and intermittent liquid or solid absorption system and adsorption systems for refrigeration purpose in rural or remote locations of developing countries, and concluded that with probable increase in the costs of conventional energy sources, solar cooling technologies are expected to become competitive with the conventional systems in future.

Modi *et al*, 2009 studied the feasibility of operating a domestic electric refrigerator with solar photovoltaic system. They chose a conventional domestic refrigerator for this purpose and redesigned by adding battery bank, inverter and transformer, and powered by solar photovoltaic

(SPV) panels. Various performance tests were carried out to study the performance of the system. The coefficient of performance (COP) was observed to decrease with time from morning to afternoon and a maximum COP of 2.102 was observed at 7 AM. They concluded that it was technically feasible to convert an existing 165 l refrigerator to photovoltaic refrigerator. Under normal operating conditions, the modified refrigerator performed similar to a conventional domestic refrigerator working on grid electricity. The normal running test and pull down test indicated that 140Wp photovoltaic capacity and two 12 V-135 A h battery bank was the least possible configuration required for this converted system to work properly under normal ambient conditions. However, for a sustainable system, larger PV module capacity or larger battery bank are required which currently make the system economically unviable because of their high initial cost.

A PV cell is basically a solid-state semiconductor device that converts light energy into electrical energy. To accommodate the huge demand for electricity, PV-based electricity generation has been rapidly increasing around the world alongside conventional power plants over the past two decades. Figure below shows a line diagram of a solar PV system. While the output of a PV cell is typically direct current (DC) electricity, most domestic and industrial electrical appliances use alternating current (AC). Therefore, a complete PV cooling system typically consists of four basic components: photovoltaic modules, a battery, an inverter circuit and a vapour compression AC unit. The PV cells produce electricity by converting light energy (from the sun) into DC electrical energy. The battery is used for storing DC voltages at a charging mode when sunlight is available and supplying DC electrical energy in a discharging mode in the absence of daylight. A battery charge regulator can be used to protect the battery from overcharging. The inverter is an electrical circuit that converts the DC electrical power into AC and then delivers the electrical energy to the AC loads. The vapour compression AC unit is actually a conventional cooling or refrigeration system that is run by the power received from the inverter.

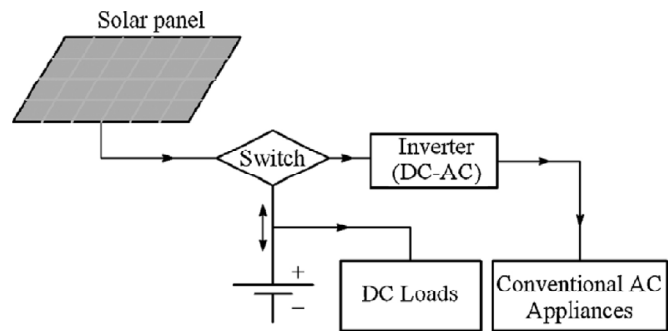

SOLAR ELECTRIC REFRIGERATION

A solar electric refrigeration system consists mainly of photovoltaic panels and an electrical refrigeration device. Solar cells are basically semiconductors whose efficiency and cost vary widely depending on the material and the manufacturing methods they are made from. Most of the solar cells commercially available in the market are made from silicon. The efficiency of a solar panel is defined by the ratio of power W (kW) to the product of solar panel surface area and the available solar radiation. Although higher efficiencies are reported from laboratories, a high-performance solar panel sold in the market yields about 15% efficiency under the midday sun in a clear day. A study on building-integrated solar panels reported an overall efficiency of 10.3%. Price of a solar panel varies widely in the market. The biggest advantage of using solar panels for refrigeration is the simple construction and high overall efficiency when combined with a conventional vapour compression system. A schematic diagram of such a system is given in the figure below. The work W is consumed by the mechanical compressor to produce the cooling power Q_c . Refrigeration machine efficiency is defined as the cooling power Q_c divided by the work input W . COP (Coefficient of Performance) is an alternative term to efficiency commonly used in thermodynamics. Solar electric vapour compression refrigeration systems are limited and only a few systems are found in literature. Several solar electric refrigeration systems were designed for autonomous operation and packaged in standard containers. Cooling COPs of the vapour compression machines in those systems ranged from 1.1 to 3.3 for different evaporator temperatures and condenser temperatures.

Monocrystalline PV modules and variable-speed compressors are used with batteries or generators as a backup.

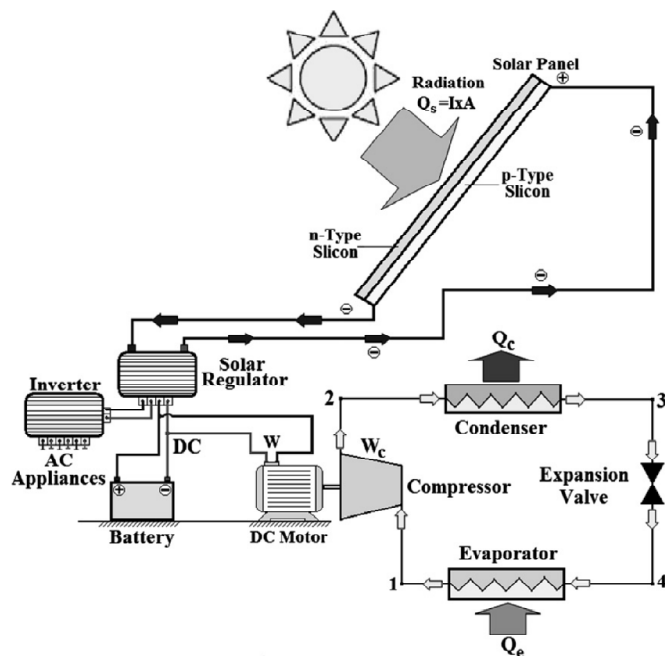

The direct use of solar energy as a primary energy source is quite interesting because of its universal availability and low environmental impact. Solar heating applications are intuitive; on the contrary, the solar energy used to obtain refrigeration is less intuitive (Mastrullo and Renno, 2010).

Solar cooling can be broadly categorized into solar electric refrigeration, solar thermal refrigeration and solar thermal air-conditioning. In the first category, the solar electric compression refrigeration uses photovoltaic (PV) panels to power conventional refrigeration machine. In the second category, the refrigeration effect can be produced through solar thermal gain. Here, the solar mechanical compression refrigeration, solar absorption refrigeration and solar adsorption refrigeration are the three common options. In the third category, the conditioned air can be directly provided through the solar thermal gain by means of desiccant cooling (Fong *et al.*, 2010).

As for the solar electrical systems, the photovoltaic solar is the most popular technology. In fact referring to traditional vapor plant, the

compressor motor can be electrically supplied by photovoltaic modules that allow the direct conversion of solar radiation into direct current. The PV system is most appropriate system for small capacity refrigeration plants used for food or medical applications in areas far from conventional energy sources, where a high level of solar radiation is present (Mastrullo and Renno, 2010).

EI Tom *et al.* (1991) presented a field test performance of PV refrigerator in the Sudan tropical climate. The PV solar refrigerator consisted of a PV solar generator, two batteries and charge regulator and refrigeration cabinet. The solar generators consisted of six pV modules of 40 W each. Each three modules were connected in parallel forming two main branch circuits each having an open voltage circuit of about 18 V. Two batteries of 12 V and 105 AH capacity each were used for energy storage to meet night and cloudy day load requirements. The energy is then supplied to the refrigerator by using charge regulator which acted as controller for charging and discharging of the batteries and protected them from overcharging as well as deep discharging. The refrigerator consisted of two deep top-open compartments (freezing and refrigerating) of 180 litre capacity. A 24 V DC motor compressor operated the refrigerator with R 12 as refrigerant.

From the data recorded, it was observed that, the water could be cooled to 273.16 K in 6 hours. During the night, the water temperature started to rise as the refrigerator stopped working due to non-availability of stored energy. The refrigerator efficiency was found to be around 77 per cent low cooling and at about 64 per cent at maximum cooling level and varied between these two values in both cases unloaded and loaded.

A solar powered refrigerated trailer has been developed by Southampton University in conjunction with industry for J. Sainsbury plc. The size of the PV array was constrained by the dimensions of the roof of the trailer. This also imposed a certain restriction for the full integration of sub-arrays within the roof. The integration design was made flexible so that sub-array could be removed for inspection and maintenance. The solar array was made of appropriately sized solar

modules of 12% conversion efficiency. A monocrystalline silicon cell solar array covering an approximate area of 35 m², was installed generating approximately 4.4 kWp power under standard conditions. The array was coupled to a charge controller and battery. An inverter was used to drive an optimized refrigeration unit. The operation of the solar-trailer was monitored using an on-board data logging system coupled to a cellular phone-modem link (Bahaj, 1998).

Nagaraju and Murthy (1999) developed a test facility to evaluate PV vaccine refrigerators under different environmental conditions. The hold over tests revealed that the refrigerator has maintained a temperature of 281.16 K in the cooling compartment even after six days without sun under an ambient temperature of 305.16 ± 1 K.

Toure and Fassinou (1999) studied the first model of SPV refrigerator with three compartments: One for vaccine and medicines storage, the second one for the personal use of the medical staff, and the third one for water freezing. A cold storage is made around the evaporator in order to give the system several days of autonomy. The cold autonomy of refrigerators in remote areas depends on several factors such as the capacity of the accumulator, the ambient temperature, insulation and air tightness. They found that at a steady rate, the mean temperatures were 277.16 and 278.16 K for vaccine compartment and medical staff compartment, respectively. The autonomy of the system due to the cold storage was about three days. The capacity of the battery used was 150 Ah. The thermodynamic study of the refrigerator was realized with a particular emphasis on exergetic analysis. The exergetic efficiency was 17%.

Eltawil and Samuel, 2007 studied the performance and economic evaluation of a solar photovoltaic (SPV) powered vapour compression refrigeration system to attain favourable conditions for potato storage under different operating conditions. The system is consisted of PV panel (490 W), lead acid battery, 1 kW inverter and 0.18 TR (tonnes refrigeration) vapour compression system. The 2.50 m³ cold storage structure was constructed and insulated with proper materials. An

evaporatively cooled storage structure (1.0 m³) was used for curing process. The cured potato cultivar (Kufri Chandermukhi) was stored for 5 months. The power output of the panel was measured under no-load, on-load, with and without recirculation of air inside cold store. The average daily SPV energy output and energy consumption by the load were 5.65 and 4.115 kWh, respectively, under full load. It was found that the output power was oversized the load demanded by the cooling system on full load by an average of 26.53%. The obtained results indicated that, the average daily actual COP for loaded and air circulated cold storage structure was 3.25. The average temperature and relative humidity maintained inside the loaded and air circulated storage structure were 283.13 K and 86 %, respectively. The total cost of curing and storing 1.0 kg of potatoes inside 2.5 m³ cold store operated by subsidized PV system, considering the weight loss of potatoes at 6%, would be Rs. 9.02 (1US \$ = 46 Rs). While the total cost for the same system operated by grid electricity (Rs. 3.5/kWh) and petrol-kerosene generator (Rs. 10.47/kWh) would be 7.66 and 14.63 Rs./kg, respectively.

Sharma and Samuel (2014) studied the feasibility of using solar photovoltaic system for lighting and refrigeration purposes in rural areas. Power from photovoltaic system was used for operation of lights, fan and a refrigerator. A solar panel of 315W (open circuit voltage 18 V) was used to operate the system. The direct current (DC) power of the solar panel was converted into single phase alternating current (AC) with the help of an 800 VA inverter. A battery was used to provide back up to the system in the absence of solar energy. With this system a load of 268 W consisting of three tube lights, one fan and a refrigerator was operated successfully.

CONCLUSION

Various solar technologies available with us today can be broadly classified into two parts: solar thermal and solar electric. Out of these, solar photovoltaic (SPV) systems from the solar electricity categories, have found widespread application because they are simple, compact and have high power-to weight ratio. Also, the SPV system has no

moving parts and in the field, SPV systems require only modest amount of skilled labour to install and maintain, making them well suited for village power systems. In order to supply the required power, the arrays should be capable of producing sufficient current and voltage to run the applications, and it can be connected in series and in parallel to obtain the desired voltage and current, respectively. The use of solar photo voltaic systems may provide good solution not only for all energy related problems of the present society but also perform excellently in terms of productivity, reliability, sustainability and environmental protection ability. With the cost of solar PV system falling steadily and price of diesel/ gasoline soaring, SPV electricity may be an appropriate and economically feasible option. Utilization and popularization of solar photovoltaic system is recognized as an important part of the future energy generation, because it is non-polluting, free in its availability, and is of high reliability. These facts therefore make the PV energy resource attractive for many applications, especially in rural and remote areas of most of the developing and tropical countries like India where there are high levels of solar radiation.

References

- Bahaj, A.S. (1998), World's first solar powered transport refrigeration system. *Renewable Energy*, 15(1-4): 572-576.
- Eltawil M. A. and D. Samuel (2007), "Performance and Economic Evaluation of Solar Photovoltaic Powered Cooling System for Potato Storage" *Agricultural Engineering International: the CIGR Ejournal*. Manuscript EE 07 008. Vol. IX. November.
- EI Tom, O.M.M. Omer, S.A., Taha, A.Z. and Sayigh, A.A.M. (1991), Performance of a photovoltaic solar refrigerator in tropical climate conditions. *Renewable Energy*, 1(2):199-205.
- Fong, K.F., Chow, T.T., Lee, C.K., Lin, Z., Chan, L.S., (2010), Comparative study of different solar systems for buildings in subtropical city. *Solar Energy* 84, 227-244.
- Jain .D (2007), Development and testing of two-stage evaporative cooler. *Building and Environment* 42 (2007) 2549-2554.
- Mastrullo, R., Renno, C., (2010), A thermoeconomic model of a photovoltaic heat pump. *Applied Thermal Engineering* 30, 1959-1966.
- Modi Anish, Anirban Chaudhuri, Bhavesh Vijay, Jyotirmay Mathur. Performance analysis of a solar photovoltaic operated domestic refrigerator. *Applied Energy* 86 (2009) 2583-2591.
- Nagaraju, J. and Murthy, M.V.K. (1999), A test facility for Photovoltaic refrigerators. *SESI Journal*, 9(1): 11-22.
- Navigant, (2006), A review of PV inverter technology cost and performance projections. In: National Renewable Energy Laboratory.
- Sharma P.K. and D V K Samuel. (2014), Solar Photovoltaic (PV) powered system for lighting and refrigeration for use in rural areas. *Agricultural Engineering Today*, vol. 38(2), 2014: 18-21.
- Toure, S. and Fassinous, W.F. (1999), Cold storage autonomy in a three compartments photovoltaic solar refrigerator: Experimental and thermodynamic study. *Renewable Energy*, 17(4): 587-602.