

# Detection and Prediction of Seizures using a Wrist-based Wearable Platform

Ganesh Raam K\* and Sasikala R\*\*

**Abstract:** Seizure is a neurological disorder that occurs due to sudden electrical activity in the brain. A number of physiological signals can be used to detect seizure. This paper describes a wrist-based platform that uses a combination of physiological signals and other parameters such as irregular, uncoordinated motion for the detection of seizure. The proposed device is capable of constant evolution by updating of its algorithms, leading to a device capable of predicting seizures before their actual onset.

**Index Terms:** Seizure, Epilepsy, Detection, Prediction, Febrile seizure, Physiological Signals, Motion, Electrodermal Activity, Photoplethysmogram.

## 1. INTRODUCTION

Seizure is a sudden surge of electrical activity in the brain triggered due to complex chemical changes that occur in nerve cells. The causes for these changes are widespread and vary from patient to patient. Causes of seizures can include fever (particularly in young children), brain injury, abnormal levels of sodium or glucose in the blood, brain infection including meningitis, brain tumor, head injury, heart disease, stroke, malignant hypertension, withdrawal from alcohol to name a few. In some cases of seizure occurrence, no cause can be found and these seizures being termed as idiopathic seizures [29][30].

Febrile seizure is a seizure associated with a high body temperature that most commonly occurs in children between the ages of 6 months and 5 years. Most seizures are less than five minutes in duration but some may last as long as 30 minutes [31]. Febrile seizures are believed to occur due to an immature / hypersensitive hypothalamus in the brain [28]. The hypothalamus is the portion of the brain responsible for core temperature regulation. In young children it is still a developing portion of the brain, and it is susceptible to hypersensitive reactions to slight increases in body temperature [32].

Epilepsy is a chronic disorder of the brain characterised by recurrent, unprovoked seizures (single seizure is not considered to be epilepsy). It is the fourth-most common neurological disorder that affects people of all ages, after migraine, stroke and Alzheimer's [13]. Around 60 million people in the world are affected by epilepsy, with almost 200,000 being added every year [33]. An estimated 3 million Americans suffer from epilepsy, putting the number at 1 in every 26 [34]. A meta-analysis of published and unpublished studies conducted in 2003 approximated the overall prevalence rate of epilepsy in India at 5.59 per 1,000 population [10]. The worldwide prevalence of active epilepsy is between 4 and 10 per thousand population. Studies from developed countries and a few developing countries suggest that the incidence of epilepsy is higher in developing countries - more than 100/100,000 population versus fewer than 100/100,000 in developed countries [19].

Febrile seizures are the most common type of convulsions in infants and young children and occur in 2 to 5 percent of American children before age 5. In Japan the rate of incidence was found to be between 6% to 9% and 14% in India and Guam [1]. A study conducted in Calicut district, Kerala in 1997 found out

\* Department of Electronics and Instrumentation Engineering, SRM University, Chennai, India. Email: ganesh\_kumarasamy@srmuniv.edu.in

\*\* Department of Electronics and Instrumentation Engineering, SRM University, Chennai, India. Email: sasikala.r@ktr.srmuniv.ac.in

that 10.1% of the total screened children had at least one instance of febrile seizure, with 2.7% going on to develop epilepsy [24].

## **2. RISKS OF SEIZURE AND EPILEPSY**

It is estimated that up to 50,000 deaths occur annually in the U.S. from status epilepticus (prolonged seizures), Sudden Unexpected Death in Epilepsy (SUDEP), and other seizure-related causes such as drowning and other accidents. SUDEP accounts for 34% of all sudden deaths in children [2].

Studies have found that complications associated with the occurrence of febrile seizures include loss of consciousness, injury and aspiration of saliva or vomit into the lungs during a seizure [35]. Potential risks include a high rate of recurrence and a slightly increased risk of epilepsy later in life [36].

## **3. PHYSIOLOGY OF SEIZURES**

Different types of seizures have different symptoms. Grand mal or generalised seizures are characterised by unconsciousness, convulsions and muscle rigidity. Tonic seizures involve muscle stiffness and rigidity whereas clonic seizures involve repetitive jerking movements. Myoclonic seizures on the other hand involve sporadic, jerking movements [15].

During a febrile seizure, a child often loses consciousness and starts moving limbs on both sides of the body in an uncontrolled and uncoordinated manner. In some instances, the child becomes rigid or has twitches in only a portion of the body, such as an arm or a leg, or on the right or the left side only. Most febrile seizures last a minute or two, although some can be as brief as a few seconds while others last for more than 15 minutes. The majority of children with febrile seizures have rectal temperatures greater than 100.4 F (38.0 C). Most febrile seizures occur during the first day of a child's fever. Thus seizure is the first indication of an illness in the patient [36].

An age-related study of seizures reveals that epilepsy has a bimodal distribution within infancy and old age (over 65 years of age). This has been attributed to certain causes of seizures and epilepsy being more common in children (such as difficulties during birth, brain's sensitivity to small changes in temperature, childhood infections and accidents) and in the older population (stroke, hypertension) [2].

## **4. TREATMENT**

Treatment for seizure and epilepsy consists of two phases during the seizure (immediate/emergency treatment) and after the seizure (treatment plan).

### **Immediate Treatment and First Aid**

First aid during seizure involves protecting the person from physical injury such as falls, bruises, cuts and burns. It is advisable to position the patient on his or her side so that fluid that collects in the back of the throat can flow out from the mouth and not get aspirated. This position is termed as "recovery position."

When the seizure exceeds 5 minutes in duration or when a cluster of seizures occur within a span of 30 minutes, additional measures have to be taken to administer certain medication to the patient. The primary purpose of this treatment is to prevent the onset of status epilepticus in patients. It involves the use of medicines such as oral or anal gel suppositories. To treat seizures, midazolam is mainly administered to the patient in two forms – buccal and intranasal. Diazepam is another benzodiazepine which is injected to the patient rectally. A rectal dose of 0.5 mg/kg (maximum 10 mg) of injectable diazepam can stop seizures in up to 80% of children [22]. Since diazepam is lipid soluble, it can enter the brain readily, enabling it to terminate seizures quickly. The side effects of midazolam and diazepam include drowsiness, amnesia, and tiredness [9].

## Long-term Treatment

Epilepsy is usually treated with medications called anti-epileptic drugs (AEDs). AEDs aim to stop seizures from happening, but they do not cure epilepsy.

Treatment of febrile seizures involves reduction of temperature of the body in addition to the above-mentioned steps. This is done with the help of antipyretics such as ibuprofen and paracetamol. Removal of unnecessary clothing and bedding and application of cold washcloths will help in improving circulation and reduction of temperature.

## 5. PRODUCT REVIEW

The following section gives a state-of-the-art review of the existing products in the market available for detecting febrile seizures as well as seizures in general.

Seizure alert devices are available in three types or form factors:

- A. Mattress-based
- B. Wrist-based
- C. Camera/Video-based

### Mattress-based Devices

Mattress-based devices generally function as sleep monitoring devices that detect anomalies in movement during sleep. They are placed under the mattress and on top of the bed on which the patient under observation sleeps. They detect vibrations and sound the alarms when seizure-like movements are detected. Some devices also include a microphone for sound detection since some patients may vocalise during or preceding a seizure.

#### Emfit Movement Monitor (Emfit MM)

Emfit MM is a device that detects muscle jerking movements. When the duration of continued jerking movements exceeds a preset time (over 10 seconds), a quick and high-frequency alert is sounded. The product consists of two components – a flexible and durable bed sensor and a bed-side monitor/control unit.

The sensor is made of an electromechanical film which functions as a quasi-piezoelectric material [3]. Sensitivity can be adjusted for a range of weights from children aged 2 years to adults. The sensor is capable of picking up micro-movements, including heartbeat and breathing, and fast movements such as muscle spasms. When movements on the bed are faster than normal movements, such as turning over, the monitor detects this as the clonic phase of a tonic-clonic seizure. The bed sensor is placed under the mattress and can detect heavy as well as light movements, making it suitable for placement under children's beds.

Studies found out that when compared to other bed monitor devices designed for nocturnal seizure detection [4], the Emfit monitor performed better than its counterparts. It was able to capture 85% of generalised tonic-clonic seizures during sleep and 75% when the patient was awake [5].

#### Medpage MP5 Tonic/Clonic Seizure Movement Alarm and its Variants

The Medpage MP5 is a tonic/clonic seizure movement alarm placed under the bed for detection of seizure-like movements. The device consists of a patented movement sensor placed under the mattress of the patient at shoulder height position along with a monitor which controls the sensor parameters such as sensitivity for patient body weight and mattress type. To aid reliable detection of minor convulsive seizures, a built-in microphone, with frequency tuned to detect human sounds, continually monitors for sound. A gain (sound

level) control allows the optimum sound detection level to be set, with the setting also digitally stored to prevent tamper and for analysis at a later stage. Detected sounds result in an alarm transmission to the caregiver's pager.

During a convulsive tonic-clonic seizure the sensor identifies the unusual prolonged movements. Seizure movement can be detected as quickly as 5 seconds, depending on settings as described above. The monitor then transmits an alarm signal to the caregiver's pager supplied as part of the system.

The MP5 is suitable for people aged 3 and above with a minimum weight of 18lbs. Variants of the Medpage MP5 include the MP5V2 as well as the MP5 Ultra.

### **Wrist-based Devices**

Mattress-based devices can only be used for nocturnal monitoring but wrist-based devices offer a compact form factor and continuous monitoring of the patient.

#### ***Smart Watch***

The Smart Watch is a watch-like device developed by Smart Monitor Inc., that detects irregular, repetitive movement of an extremity [7]. On detection, the device sends a signal via Bluetooth link to a computer, alarm device, or smart phone, which logs the event date and time, duration of the movements, and complete motion data which can be viewed in a graphic plot [7].

When a seizure-like movement is detected, it sends out an alert consisting of a short series of high-pitched audible beeps and an alarm indicator on the Smart Watch lights up. The device can be worn on the wrist or ankle of the patient. A miniaturized three-dimensional motion/accelerometer sensor detects fine and gross movements of the body part on which the watch is worn. The Smart Watch has an algorithm embedded inside it that uses pattern recognition and feature analysis to detect a seizure.

The device has a "Help" button that when pressed immediately sends an alert to a caregiver, even in the absence of a seizure. It also consists of a buzzer to indicate an audio alarm [7].

#### ***Embrace***

Embrace from Empatica Inc., is a bracelet-like wrist-worn device that is used to detect epileptic movements such as convulsive seizures. The device comprises of several sensors that help in comprehensive detection of several parameters involved in the detection of epilepsy and seizures [2]. The device consists of an accelerometer, gyroscope, temperature sensor and an electrodermal activity sensor embedded in an analogue watch-like device.

The Embrace watch is suitable for use by people of all ages since it has no weight restrictions such as those present in mattress devices. The device is used for detection of febrile seizures since it has a temperature sensor included.

#### ***EpiLert***

EpiLert is a watch-like sensor unit worn by the patient on the hand or the foot that warns caregivers of an ongoing epileptic seizure. The sensor unit consists of a 3-axis accelerometer whose movement is used for detection of seizure.

The device transmits the GPS coordinates to facilitate patient location identification and uses cellular network for transmitting alerts to caregivers.

## Camera-based

Camera devices record audio and video information from a remote infrared video camera. The recorded information is sent to a smart phone and an application records and analyses the video for seizure-like activity. When an unusual event is detected, an alarm is sounded, followed by live sound and video streaming from the camera.

### *SAMi Sleep Activity Monitor*

SAMi is a night-time camera that pairs with a smartphone application through a Wi-Fi connection. When the person under observation is sleeping, infrared and nearly invisible LED lights illuminate the bed. A night-time camera records video and when it recognises sufficient continued motion, it triggers an alarm on the caretaker's smartphone. The smartphone then switches to video and audio mode automatically. Additionally, all movement is recorded and suspected seizures are highlighted within the application. The motion-sensitive camera is programmed to ignore short movements such as rolling over, leg twitching, etc.

## 6. REVIEW OF PHYSIOLOGICAL SIGNALS AND OTHER PARAMETERS

There is a need for ambulant seizure-detection systems that can be used for seizure detection at home as well as for long periods of time. The primary method of seizure detection or gold standard is the use of video/EEG (electro-encephalography), which involves the measurement of the electrical activity of the brain. But this method is not patient-friendly as EEG electrodes are attached to the scalp. An automated and real-time method for measurement of EEG signals is yet to be found.

The other methods for seizure detection involve two main categories – irregular movement detection and measurement of various physiological or body signals. The parameters to be measured depend on the type of seizure affecting the patient as well as the patient's age.

### **Detection of Abnormal Movement**

Abnormal movement detection is primarily done using video, accelerometers, gyroscopes, magnetometers and electromyography (EMG). When attached to one of the four limbs of the body, a combination of accelerometer, gyroscope and magnetometer can be used to detect rapid, uncoordinated movements that occur during seizures.

### **Video**

Using video recording is one of the gold standards for seizure detection [2]. The advantages of video detection include its non-invasive nature, the ability to analyze video in order to detect patterns associated with previous occurrences of seizure. Possible downsides include obstruction of video signal by use of blankets, since detecting body movements inside a blanket is difficult. The patient must also be in the field of view of the camera at all times of recording, which limits the locations where this method can be used.

An alternative could be the use of thermographic or infrared camera which detects infrared waves from the body and can consequently be used to detect body movements through clothing. These cameras have the option of wall-mounting as well as wireless connectivity with a mobile phone or tablet. Some cameras have infrared illuminators that help in getting a good-quality image even in complete darkness. The disadvantages include low resolution of the camera when compared to optical cameras and the cost.

### **Using Accelerometer, Gyroscope and EMG**

An accelerometer is a device used to measure proper acceleration or g-force, which is the acceleration relative to a free-fall, or inertial observer who is momentarily at rest relative to the object being measured

and is different from coordinate acceleration. Accelerometers generally measure acceleration in three axes X, Y and Z and are used for detection of movements when placed on the patient's extremities. They consume low power, come in small form factor and are low in cost. They can be used for detecting clonic seizures which involve muscle spasms and jerky movements.

Gyroscopes are devices that can measure rotational acceleration or tilt. Thus they are used to detect seizures where the patient's limbs suffer a rotational acceleration such as during a fall.

EMG or electromyography involves the measurement of electric signals due to muscular activity. EMG signals are generally obtained from the forearm or deltoid muscles. Since they measure muscular activity or movement, they are used for the detection of the tonic phase of a tonic-clonic seizure, helping in early detection.

### **Temperature**

In case of febrile seizures, temperature is an important parameter to be measured since the primary cause of seizure is the occurrence of fever. Since a child's brain is more susceptible to fever than an adult brain, febrile seizures occur in children below 6 years of age, mostly between 12 and 18 months [12].

In many cases, febrile seizures are due to viral and bacterial infections such as chicken pox, influenza, etc. Thus a febrile seizure may be the first indication of manifestation of an infection. Febrile seizure is generally associated with a sudden increase in core temperature rather than the absolute temperature itself [32].

Febrile seizures are believed to be due to an immature/hypersensitive hypothalamus in the brain. The hypothalamus is the portion of the brain responsible for homeostatic core temperature regulation and in young children it is still a developing portion of the brain, meaning it is susceptible to hypersensitive reactions to slight raises in body temperature [32].

Conventional methods of temperature measurement include the use of a digital thermometer placed in the mouth of the child below the tongue. Disadvantages to this method include its difficulty in use, inability to provide continuous measurement and discomfort caused to the child.

Life Patch, a small, non-invasive real-time temperature monitoring system has been designed for children who suffer from febrile seizures. Using an infrared thermometer, the device is used to measure the core body temperature of children. When the temperature becomes too high, the patch sends an alert to the Relay Unit which is placed in the same room as the child.

### **Electrodermal Activity (EDA)**

Electrodermal activity or galvanic skin response is the measurement of the arousal of the sympathetic nervous system. Skin conductance or impedance is measured by using galvanometers or ohm-meters in the form of electrodes.

The autonomic nervous system is subdivided into sympathetic and parasympathetic nervous systems. Sympathetic nervous system controls the fight-or-flight response of the human body. Sympathetic activation increases while experiencing excitement or stress, be it physical, emotional or cognitive. Sympathetic activation also shows significant increases that correspond to the activation of specific brain structures.

Sympathetic activation can be measured by measuring subtle electrical changes across the surface of the skin that occur due to sympathetic activation. Since the skin is not affected by parasympathetic activation, this measurement is a reliable parameter for the detection of epilepsy. A study established that the distal forearm is a viable alternate location for EDA measurements than the traditional finger or palmar sites [10].



Another aspect of EDA measurement was the detection of the PGES (Post-ictal generalised EEG suppression) in cases of SUDEP (sudden unexpected death in epileptic patients), leading to the conclusion that PGES was an important biomarker for SUDEP. The duration of PGES which occurred as a suppressed or flat EEG signal was associated with PGES greater than 20 seconds after a convulsive seizure was associated with higher SUDEP risk, which increased proportionally with PGES duration [11]. The duration of PGES correlates with the size of the EDA measured on the wrist.

A study done between biofeedback and epilepsy found out that patients who were able to control their EDA using biofeedback were able to reduce the occurrence of seizures [8].

## Heart Rate

Seizure-related heart rate changes are common in occurrence. In most cases seizure-related cardiac changes are transient and do not appear to cause clinically significant abnormalities for the patient. Seizure-related cardiac changes have assumed greater importance in the recent years due to a possible connection with sudden unexpected death in epilepsy (SUDEP). The serious ones are very high rates that interfere with the heart filling with blood, or pauses in the heart rate.

A study found out that the most common pattern of heart rate changes during complex partial seizure was steep increase at the onset of the seizure followed by variations during and after the seizure [26]. The study also found that the pattern of changes of heart rate during and after seizure were markedly similar for seizures within the same patient.

Another study found that out of 106 occurrences of lateralized and general seizures, 93% of them were characterised by an ictal tachycardia of greater than 100 beats per minute [27].

A study found that there was an increase of at least 10 beats per minute in heart rate in 73% of seizures and in 93% of patients. The findings were in concurrence with a previous study [26] and concluded that heart rate changes occur frequently around the onset or even before the earliest electrographic or clinical change. The specific patterns in changes in heart rate may aid in automated seizure detection. Sinus rate change is the most common cardiac phenomenon that accompanies ictal discharge with sinus tachycardia reported in 50–100% of seizures [17] [25].

HRV (heart rate variability, the physiological phenomenon of variation of time interval between heartbeats), is an indicator of autonomic nervous activity. HRV analysis has been used for stress analysis as well as cardiovascular disease monitoring. Changes in heart rate variability have been found in patients with juvenile myoclonic epilepsy [23] as well as in temporal lobe epilepsy [6].

## 7. SUMMARY OF REVIEW

Despite there being several devices for the detection of seizures and febrile seizures in particular, each device has its own pros and cons owing to the large number of parameters associated with seizure detection. The first devices for seizure detection were based on accelerometry, either in the form of a wearable (wrist or ankle) device or mattress-based. Due to breakthroughs in research, certain physiological signals were determined to be indicators for the onset of seizure and epilepsy, as a result of which these parameters were incorporated into seizure-detection devices [2]. It was found that those devices that had a combination of motion detection and detection of changes in associated physiological parameters were found to be more efficient in detecting seizures than those devices that measured a single factor alone [2].

Thus the need of the hour is a multimodal system that has the ability to measure changes in those physiological parameters, mainly cardiac and autonomic signals that are indicators of seizures.

## 8. PROPOSED METHODOLOGY

As mentioned in the summary of the review of existing techniques (see Section VII), a device that measures all the vital parameters that indicate the occurrence of seizure has not been fabricated. The proposed device (see Figure 1) aims to build a wrist-based comprehensive system with multimodal seizure detection methods. The goal is to build a platform that deals with febrile seizures as well as seizures in a comprehensive manner consisting of three main phases - (i) Detection of seizures (ii) Continuous monitoring and data collection and (iii) Prediction of future occurrences of seizures.

After reviewing existing devices and methods for detection of seizures and considering the advantages and disadvantages of every method, it was concluded that seizure detection would primarily involve the measurement of the following parameters - (i) motion, (ii) electrodermal activity (EDA), (iii) skin temperature and (iv) heart rate. A simultaneous measurement of all the aforementioned parameters would increase the efficacy of the seizure detection.

### Skin Temperature Measurement

Since temperature is a vital parameter to be measured while detecting a febrile seizure (see Section VI), the device has a skin temperature sensor (a calibrated thermistor) with an accuracy of  $\pm 0.1^{\circ}\text{C}$ . The sensor continuously monitors the skin temperature for any sudden increase or decrease in value.

### Motion Detection

Motion detection is performed using two sensors – a 3-axis accelerometer and a gyroscope (see Section VI). A motion detection algorithm is used that factors in plausible daily activities that could trigger false alarms and ignore them. These activities include scratching the head, opening of a bottle, shaking a bottle, bathing, to name a few [7]. Provision to snooze the device's alarm during activities such as exercise is provided in the form of a button so as to prevent false alarms.

### Electrodermal Activity (EDA)

Since skin is the only organ that is affected by the sympathetic nervous system and not by the parasympathetic nervous system, electrodermal activity (EDA) can be used for seizure detection. When sweat glands are aroused, the electrical conductance of the skin changes. These changes can be detected by measuring EDA. EDA is measured using electrodes attached to the strap/band of the device. Stainless steel/silver electrodes can be used for this purpose. A small alternating current is sent to the skin through these electrodes. The electrodes then measure change in skin conductance due to changes in the autonomic nervous system. The sampling rate for this method is 4 samples per second (S/s) for EDA at an excitation frequency of 100 Hz.

### Heart Rate

Heart rate of a patient is measured using reflectance photoplethysmography (PPG). In reflectance photoplethysmography, light is emitted onto the tissue and the reflected light is measured by the detector (a photo diode). The detected light reflected from the body part will fluctuate because of the pulsatile blood flow caused by the beating of the heart [14]. Heart rate is calculated using the time interval between two successive peaks of maximum light absorbance and reflectance. The wavelength of LED used as light source in PPG is 570nm with a sampling rate of 30 S/s. A challenge in using this method is the occurrence of motion artifacts due to the movement of the device from an optimal position as well as the movement of the patient/user [21].



### Connectivity

The device connects to a mobile phone application through Bluetooth Low Energy (BLE), which is a wireless personal area network technology with low power consumption. The application sends data to a cloud-based server, which has an advantage of access from anywhere. This data can be accessed by a physician or doctor periodically, to check for any abnormalities. The device also has a rechargeable battery that can be charged via a USB port, thereby also providing connectivity with a PC for data transfer to the server.

### Data Analysis and Seizure Prediction

The proposed device is a continuously upgrading platform that evolves from a seizure detection device to a seizure prediction device by performing large-scale data collection from people of all ages suffering from different types of seizures and epilepsy. Seizure-affected people are analyzed for long periods that include before the occurrence of seizure, during a seizure and after a seizure. Data is stored in the cloud (see Fig. 2) for use by physicians. Data obtained is then analysed using data analytics methods to identify and detect patterns in the various individual physiological parameters, thus enabling the device to learn and modify seizure detection algorithms from the acquired data.

Studies have shown that heart rate and heart rate variability show variability prior to the onset of seizure. The results of a study performed in 2002 show that the heart rate increased by at least 10 beats per minute in 73% of the seizures, occurring mostly during the onset of the seizure. The study also found that in 23% of seizures and 49% of patients, the changes in heart rate happened prior to the signs of electrographic and clinical seizures [20]. The findings of another study indicated that tachycardia preceded the onset of seizure in some patients with temporal lobe epilepsy, thus helping in prediction of seizures [16][18].

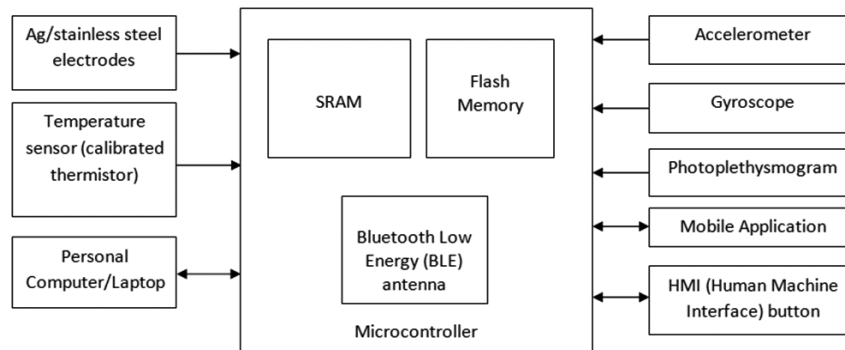

Figure 1: Generalised block diagram

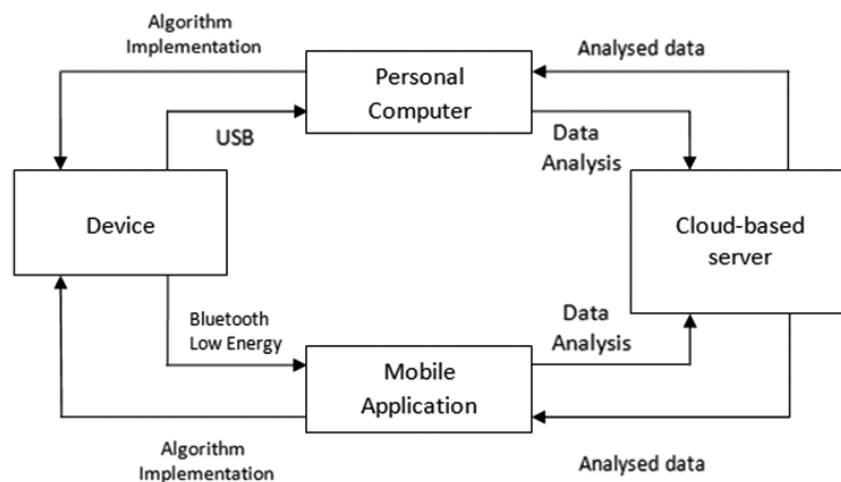

Figure 2: Cloud-based server connectivity

## 9. CONCLUSION

The existing methods of detection of febrile seizures and seizures in general generally focus on a single modality of detection and do not take into consideration all the parameters that can cause a seizure. This paper proposes the design, development and validation of a wrist-based wearable device that can not only detect seizure efficiently, but over time can also predict a seizure before the actual onset.

## References

1. Nikhil Patel, Dipak Ram, Nina Swiderska, Leena D Mewasingh, Richard W Newton, Martin Offringa, *Febrile seizures*, *BMJ* 2015;351:h4240
2. Anouk Van de Vel, Kris Cuppens, Bert Bonroy, Milica Milosevic, Katrien Jansen, *Non-EEG seizure-detection systems and potential SUDEP prevention: State of the art*, *Seizure* 22 (2013) 345–355
3. Aditi P. Narechania, Irena I. Garic, Indranil Sen-Gupta, Mícheál P. Macken, Elizabeth E. Gerard, Stephan U. Schuele, *Assessment of a quasi-piezoelectric mattress monitor as a detection system for generalised convulsions*, *Epilepsy & Behavior* 28 (2013) 172–176
4. Fulton S, Van Poppel K, McGregor A, et al, *Prospective study of 2 bed alarms for detection of nocturnal seizures*, *J Child Neurol* November 2013 vol. 28 no. 1
5. Kate Van Poppel, Stephen P. Fulton, Amy McGregor, Michelle Ellis, Andrea Patters, and James, *Prospective Study of the Emfit Movement Monitor*, *Wheless Journal of Child Neurology* 28(11) 1434-1436, 2013.
6. Ponnusamy A, Marques JL, Reuber M, *Comparison of heart rate variability parameters during complex partial seizures and psychogenic non-epileptic seizures*, *Epilepsia* 2012;53(8):1314–21.
7. Lockman J, Fisher RS, Olson DM, *Detection of seizure-like movements using a wrist accelerometer*, *Epilepsy and Behavior* 2011; 20:638-41
8. Nagai, Y. (2011). Biofeedback and epilepsy. *Current Neurology and Neuroscience Reports*, 11(4), 1-8. doi:10.1007/s11910-011-0201-3.
9. Uzun S, Kozumplik O, Jakovljević M, Sedić B, *Side effects of treatment with benzodiazepines*, *Psychiatr Danub*. 2010 Mar; 22(1):90-3.
10. Poh, M. Z., Swenson, N. C., & Picard, R. W., (2010), *A wearable sensor for unobtrusive, long-term assessment of electrodermal activity*, *IEEE Transactions on Biomedical Engineering*, 57(5), 1243-1252
11. Lhatoo SD, Faulkner HJ, Dembny K, Trippick K, Johnson C, Bird JM, *An electroclinical case-control study of sudden unexpected death in epilepsy*, *Ann Neurol* 2010;68:787–796.
12. Mogens Vestergaard, Jakob Christensen, *Register-based studies on febrile seizures in Denmark*, *Brain Dev.* 2009 May; 31(5)::372-7
13. Hirtz D, Thurman DJ, Gwinn-Hardy K, Mohamed M, Chaudhuri AR, Zalutsky R, *How common are the “common” neurologic disorders?*, *Neurology* 2007; 68(5):326–337
14. J. Allen. *Photoplethysmography and its application in clinical physiological measurement*. Physiological measurement, Vol. 28, No. 3, p. R1, 2007.
15. Bromfield EB, Cavazos JE, Sirven JI, editors. *An Introduction to Epilepsy*. West Hartford (CT): American Epilepsy Society; 2006. Chapter 2, Clinical Epilepsy
16. Weil S, Arnold S, Eisensehr I, Noachtar S, *Heart rate increase in otherwise subclinical seizures is different in temporal versus extratemporal seizure onset: support for temporal lobe autonomic influence*, *Epileptic Disord* 2005; 7:199–204.
17. Rugg-Gunn FJ, Simister RJ, Squirrell M, Holdright DR, Duncan JS, *Cardiac arrhythmias in focal epilepsy: a prospective long-term study*, *Lancet* 2004; 364:2212–19.
18. Di Gennaro G, Quarato PP, Sebastiano F, Esposito V, Onorati P, Grammaldo LG, et al., *Ictal heart rate increase precedes EEG discharge in drug-resistant mesial temporal lobe seizures*, *Clin Neurophysiol* 2004; 115:1169–77.
19. N. E. Bharucha, *Epidemiology of Epilepsy in India*, *Epilepsia* Vol. 44, Suppl. 1, 2003
20. Zijlmans M, Flanagan D, Gotman J, *Heart rate changes and ECG abnormalities during epileptic seizures: prevalence and definition of an objective clinical sign*, *Epilepsia* 2002 Aug; 43(8):847-54.

21. P. Renevey, R. Vetter, J. Krauss, P. Celka, and Y. Depeursinge, *Wrist-located pulse detection using IR signals, activity and nonlinear artifact cancellation*, Engineering in Medicine and Biology Society, 2001, Proceedings of the 23rd Annual International Conference of the IEEE, Vol. 3. IEEE, 2001, pp. 3030–3033.
22. Charles O’Sullivan, A. Simon Harvey, *The use of rectal diazepam for the treatment of prolonged convulsions in children*, Australian Prescriber 1998; 21:35-6 | 1 April 1998
23. Torbjörn Tomson, Mats Ericson, Christina Ihrman, Lars Erik Lindblad, *Heart rate variability in patients with epilepsy*, Epilepsy Research, (1998), 30 (1), pp.77-83.
24. Hackett R, Hackett L, Bhakta P, *Febrile seizures in a south Indian district: incidence and associations*, Developmental Medicine and Child Neurology, 1997 Jun; 39(6):380-4.
25. Galimberti CA, Marchioni E, Barzizza F *et al*, *Partial epileptic seizures of different origin variably affect cardiac rhythm*, Epilepsia 1996; 37:742–7.
26. Smith PEM, Howell SJL, Owen, Blumhardt LD, *Profiles of instant heart rate during partial seizures*, *Electr Clin Neurophys* 1989; 72:207–217.
27. Keilson MJ, Hauser WA, Magrill JP, *Electrocardiographic changes during electrographic seizures*, Arch Neurol 1989; 46:1169–1170.
28. William G. Lennox, *Significance Of Febrile Convulsions*, Pediatrics, April 1953, Volume 11/Issue 4
29. What Causes Epilepsy and Seizures? – Epilepsy Foundation [Internet]. <http://www.epilepsy.com/learn/epilepsy-101/what-causes-epilepsy-and-seizures>
30. Seizures - MedLine Plus U.S. National Library of Medicine [Internet]. <https://www.nlm.nih.gov/medlineplus/ency/article/003200.htm>
31. Febrile Convulsion - The Royal Children’s Hospital Melbourne [Internet]. [http://www.rch.org.au/clinicalguide/guideline\\_index/Febrile\\_Convulsion/](http://www.rch.org.au/clinicalguide/guideline_index/Febrile_Convulsion/)
32. Causes of Febrile Seizures – FebrileSeizuresOrgUK [Internet]. <http://febrileseizures.org.uk/latest-research/causes/>
33. What is Epilepsy? – The Epilepsy Centre [Internet]. <http://www.epilepsycentre.org.au/what-is-epilepsy/>
34. Epilepsy by the Numbers: Facts, Statistics, and You - Healthline [Internet]. <http://www.healthline.com/health/epilepsy/facts-statistics-infographic#1>
35. Epilepsy - overview - MedLine Plus U.S. National Library of Medicine [Internet]. <https://www.nlm.nih.gov/medlineplus/ency/article/000694.htm>
36. Febrile seizure Fact sheet - NINDS [Internet]. [http://www.ninds.nih.gov/disorders/febrile\\_seizures/detail\\_febrile\\_seizures.htm](http://www.ninds.nih.gov/disorders/febrile_seizures/detail_febrile_seizures.htm)

