



## International Journal of Control Theory and Applications

ISSN : 0974-5572

© International Science Press

Volume 9 • Number 48 • 2016

### Control Methods of Stand-alone Wind Based Energy Sources for Small Scale Power Grid Applications

P. Sai Sampath Kumar<sup>1</sup>, K. Jagadeesh<sup>2</sup> and K. Raja Sekhar<sup>3</sup>

<sup>1</sup> Assistant Professor, Department of Electrical & Electronics Engineering, Rajeev Gandhi Memorial College of Engineering & Technology, Nandyal, Andhra Pradesh, India

<sup>2</sup> Assistant Professor, Department of Electrical & Electronics Engineering, GPCET, Kurnool, Andhra Pradesh, India

<sup>3</sup> Assistant Professor, Department of Electrical & Electronics Engineering, Rajeev Gandhi Memorial College of Engineering & Technology, Nandyal, Andhra Pradesh, India.

**Abstract:** In recent studies the usage of non-conventional energy sources, such as solar, wind and hydraulic stations, for generation of electricity has been enhanced. Where as in case of aero energy conversion system (AECS), the curiosity is also concentrated on the small units, for providing electricity use in rural areas that are away from the grid and are not cost-effectively connected to a grid. The large scale turbines reach their technical maturity, where as small scale AECS have to be additional modified to achieve assimilation in flexible micro-grids and improved reliability. In this control structure for 1kw wind turbine along with the storage device are proposed. In general due to high variable amount of the wind, the power extracted from it also highly variable. From the load point of view, load could effect from this wind variations. So we require some control strategy to maintain load power constant even though wind is variable. Energy devices are used for stability of power supply. Here speed control is done fuzzy control. The simulations results are show in the proposed control structure have good potential to maintain load power constant and by changing loads using MATLAB

**Keywords:** Stand-alone wind Turbine, Variable speed permanent-magnet generator, Fuzzy Control, Energy Storage System, Small Grid.

#### I. INTRODUCTION

It has been expected that 2 percent of all solar radiations falls on the surface of the earth is transformed to kinetic energy in the atmosphere. Conversions of the K.E of the wind to mechanical energy that can utilize to generate electricity. By using this wind energy we could able to rotate wind turbine. The wind turbine coupled with generator which is converted turbine rotational (mechanical) energy into electrical energy. There is a drastic change of global climate by flaming of fossil fuels. Efficient enhancement of climate alter will need deep reduction in greenhouse gas emission, with world estimates of a 50 to 80 percent cut being essential by 2050. Hence the use of cost-effective and consistent low-carbon emission generating sources.

Wind aerogenerators are generally classified as two types on their axis of rotation. Horizontal axis wind and vertical axis wind turbines. Horizontal axis wind turbines are having high wind energy conversion efficiency then the vertical axis wind turbines.

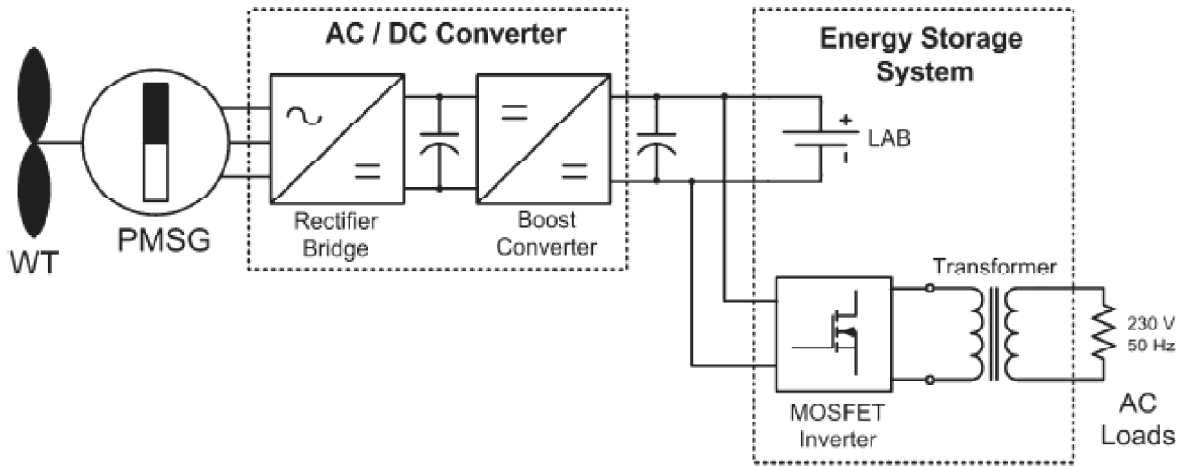

Figure 1: Wind turbine generator with energy storage scheme

The proposed stand alone wind energy scheme is supply power to the Low Tension consumer's. It is especially for domestic loads and it is for 1KW wind aeroturbine set with the following: a) PMSG, b) AC-DC converter for MPPT from the wind source with resistive loads.

## II. MODELING OF STAND ALONE WIND TURBINE GENERATOR

To study this system usually the energy in the wind can be treated as the K.E of a huge quantity of air particles with mass ( $m$ ) with velocity of wind,  $V_w$ . The potential of available K.E stores at the wind can be expressed in eqn (1),

$$E = \frac{1}{2} m V_w^2 \quad (1)$$

Where,  $E$  is K.E of the air particles,  $V_w$  is speed of the air particles, the mass of air for a time period( $t$ ) can be written in eqn (2),

$$m = \rho A V_w t = \rho \pi r^2 V_w t \quad (2)$$

Substituting expression (2) into (1), the K.E of the air particles can be represent in eqn (3),

$$E = \frac{1}{2} \rho \pi r^2 V_w^3 t \quad (3)$$

Here,  $\rho$  is density of air,  $A$  is swept area and  $r$  is radius.

From equation (3), at any instant of time actual wind power is stand for in eqn(4)

$$P_{wind} = \frac{E}{t} = \frac{1}{2} \rho \pi r^2 V_w^3 \quad (4)$$

Where  $P_{wind}$  is the wind potential energy. From expression (4), it is observe that the power of the wind is cube times of the wind speed ,that means a small change in the wind speed will tends to huge change in the wind power. Moreover, this power can also be increase by expanding the radius of the wind turbine rotor.

However, the power represented in equation (4) can stands for the maximum potential power. In the year 1919, a Albert Betz(German scientist) had made an attempt to express movement of air particles. In his view, there is still some K.E left in the wind as wind flows through the blades. The relation between the wind turbine power and the maximum potential power in the wind can be shown in eqn(5).

$$C_p = \frac{P_{Turbine}}{P_{Wind}} \quad (5)$$

Where,  $P_{turbine}$  is mechanical power and  $C_p$  power coefficient as mention in eqn(6)

$$C_p = C_1(C_2 \frac{1}{\alpha} - C_3\beta - C_4\beta^x - C_5)e^{-C_6\frac{1}{\alpha}} \quad (6)$$

Where,

$$\frac{1}{\alpha} = \frac{1}{\lambda + 0.08\beta} - \frac{0.035}{1 + \beta^3} \quad (7)$$

And,

$$\lambda = \frac{\omega_m r}{V_w} \quad (8)$$

## POWER AND TORQUE EQUATIONS

For an PMSM, the power input in the *abc* reference frame is,

$$P_{abc} = v_{as}i_{as} + v_{bs}i_{bs} + v_{cs}i_{cs} \quad (9)$$

or in the *dq* reference frame is,

$$P_{dq} = \frac{3}{2}(v_d i_{ds} + v_q i_{qs}) \quad (10)$$

The power in motoring mode is from eqn (11) to eqn (13).

$$P_{em} = \frac{3}{2}(e_d i_{ds} + e_q i_{qs}) \quad (11)$$

Where,

$$e_d = -\omega_e L_q i_{qs} = -\omega_e \lambda_q$$

and,

$$e_q = \omega_e L_d i_{ds} + \omega_e \lambda_r = \omega_e \lambda_d$$

The active power re-expressed as,

$$P_{em} = \frac{3}{2} \omega_e (\lambda_d i_{qs} - \lambda_q i_{ds}) \tag{12}$$

Hence, the electro-magnetic torque is represent in eqn(13)

$$T_e = \frac{3}{2} \left(\frac{p}{2}\right) (\lambda_r i_{qs} + (L_d - L_q) i_{qs} i_{ds}) \tag{13}$$

Where,  $p$  is number of poles.

### III. FUZZY CONTROL

Fuzzy logic having more importance in a machine control. Fuzzy logic can perform same as genetic algorithms and neural networks, the main advantage of fuzzy logic is user friendly to the human operators. A control method for a PMSG is by using the fuzzy logic controller. By using this method turbine aerodynamic efficiency can be optimized in the outer speed loop. The SVPWM technique is implemented to control the generator side converter.

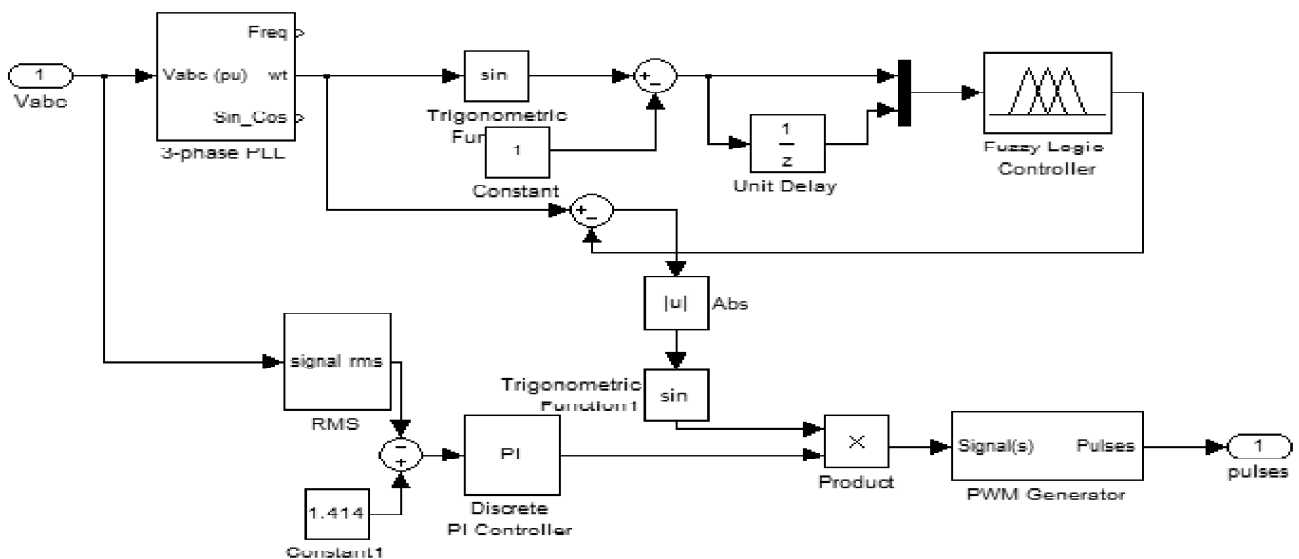

Figure 2: Schematic diagram of fuzzy logic controller

Table 1  
Fuzzy-Rule Matrix

Change of Error	LN	MN	SN	VS	SP	MP	LP
Error							
LN	LN	LN	LN	LN	LN	LN	LN
MN	LN	LN	LN	LN	LN	LN	LN
SN	LN	LN	LN	LN	LN	LN	LN
VS	LN	LN	LN	LN	LN	LN	LN
SP	LN	LN	LN	LN	LN	LN	LN
MP	LN	LN	LN	LN	LN	LN	LN
LP	LN	LN	LN	LN	LN	LN	LN

In fig.3 the regulating speed of the PMSG is fed by back to back converter.

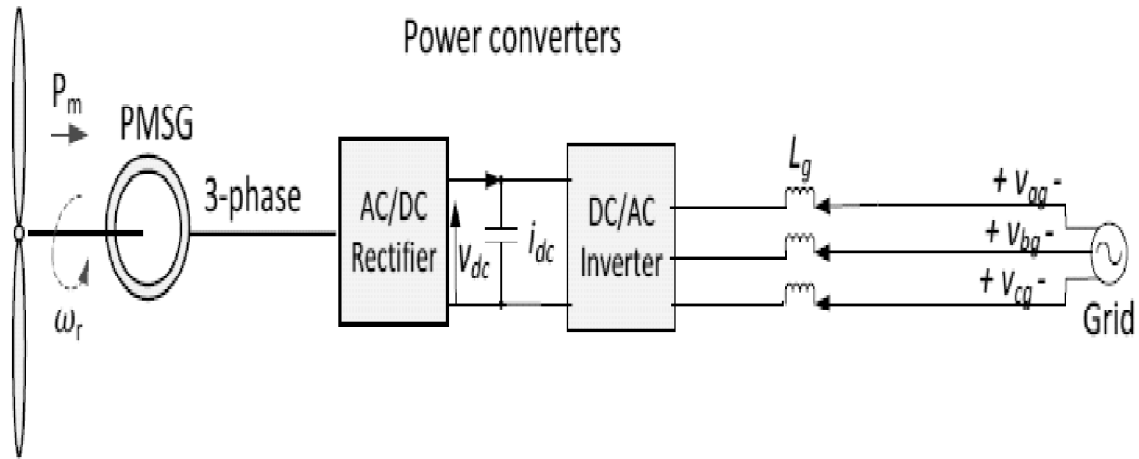

Figure 3: Direct-drive PMSG system

Fig.4 shows the boost-converter diagram for rapid transfer of power from battery to the rectifier capacitor.

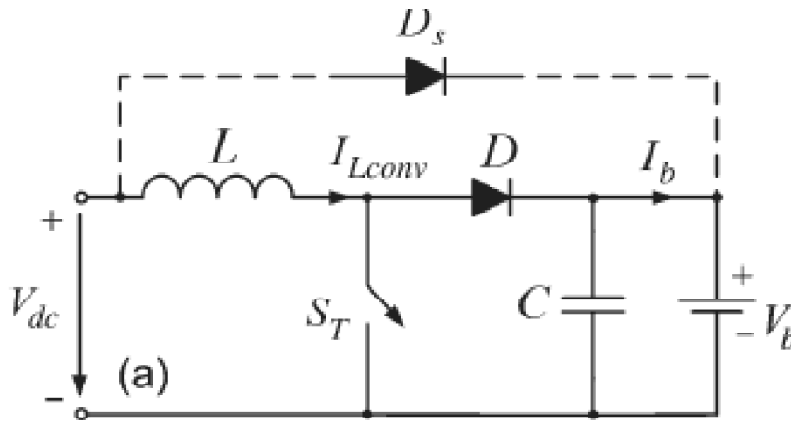

Figure 4: Boost converter diagram

The boost-converter control diagram of simplified form is as shown fig.5

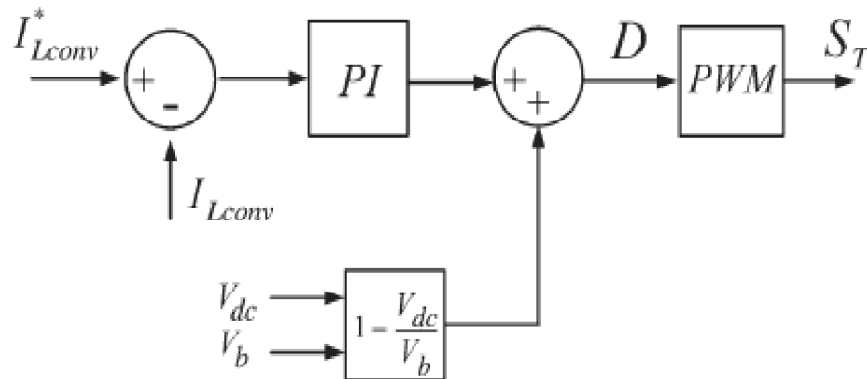
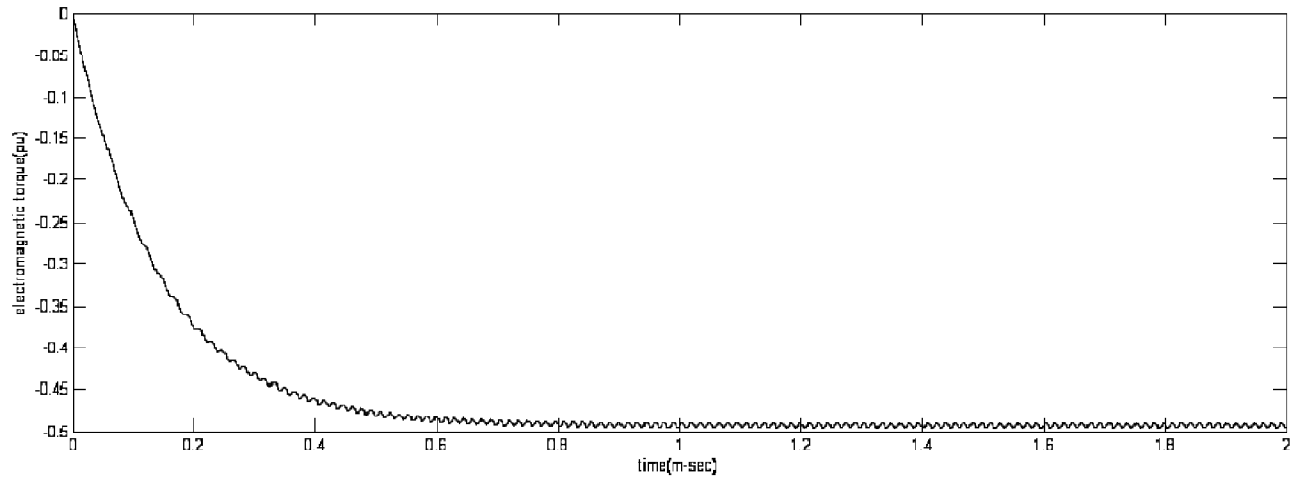

Figure 5: Boost converter control diagram

## IV. SIMULATION RESULTS AND DISCUSSION

### (A) Simulation Result of Wind Turbine at Constant Wind Speed



(a)

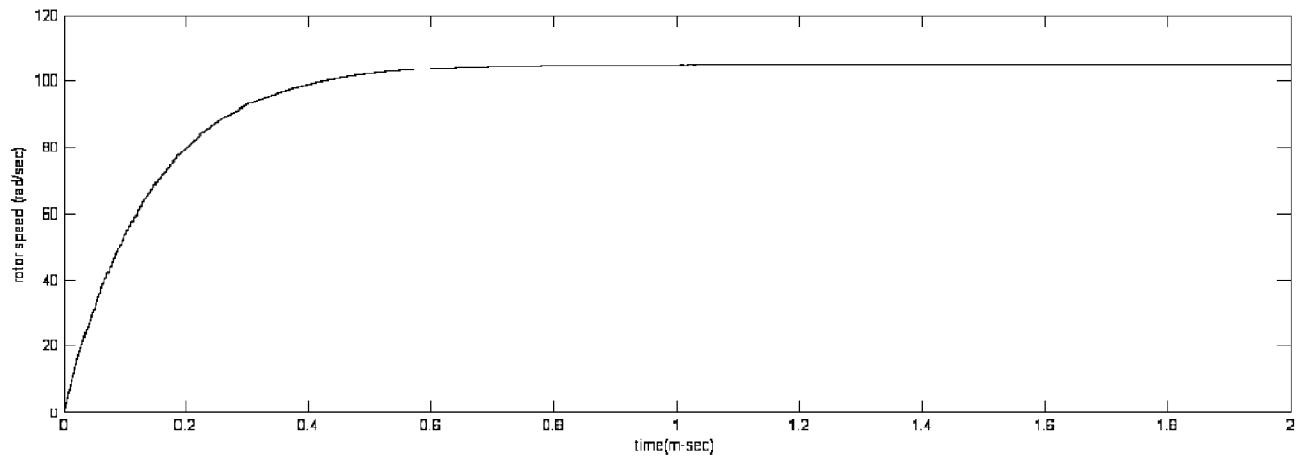

(b)

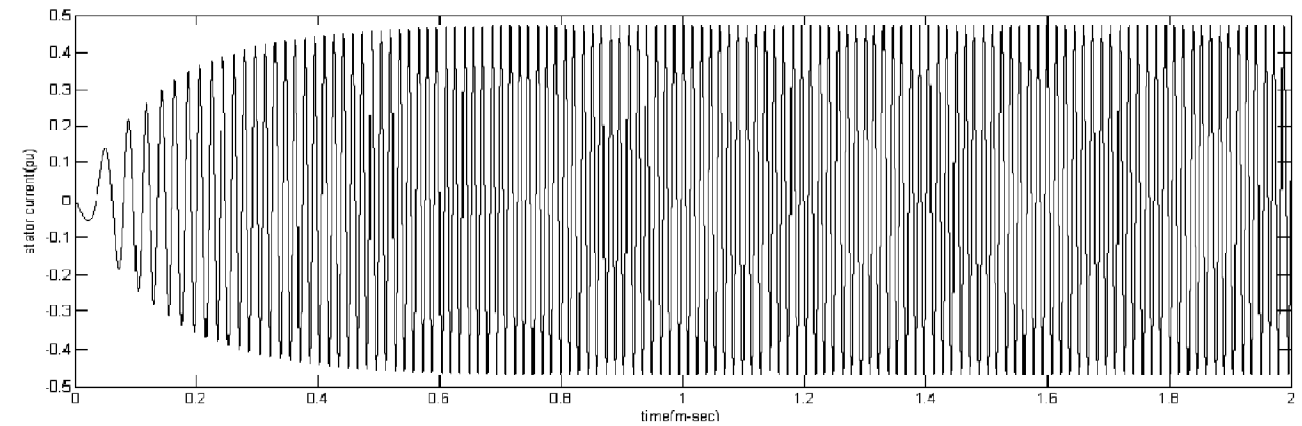

(c)

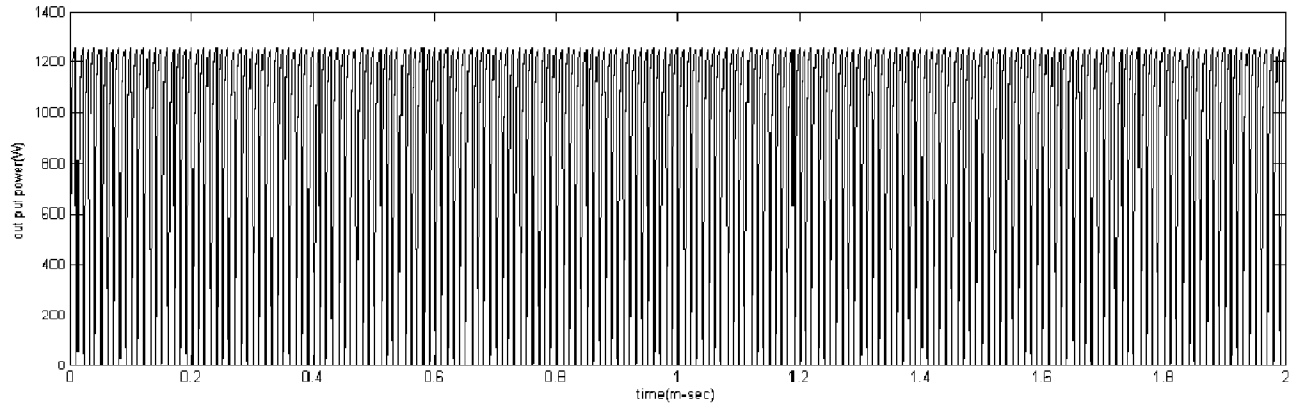

(d)

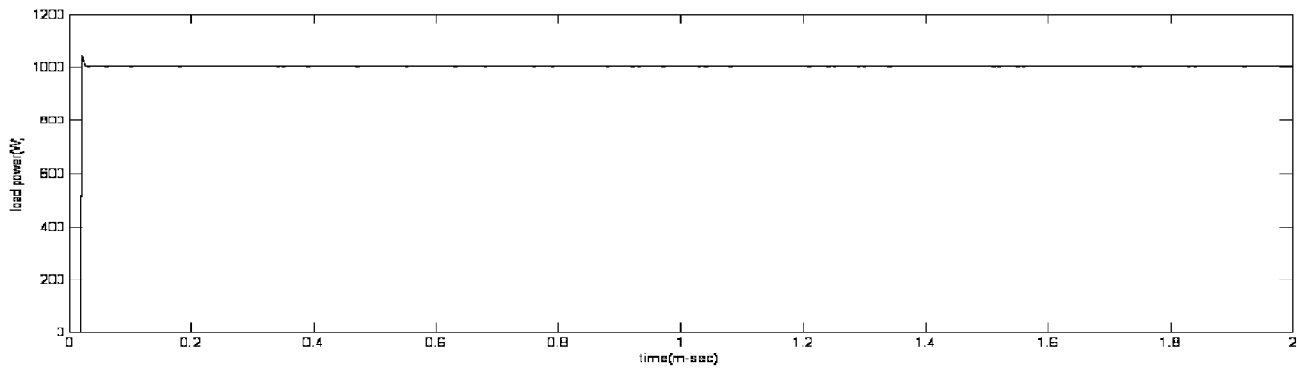

(e)

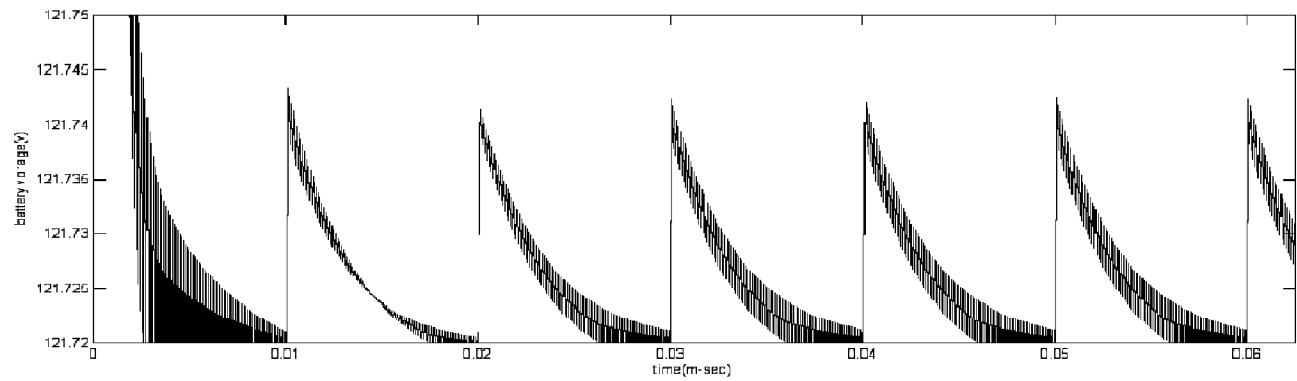

(f)

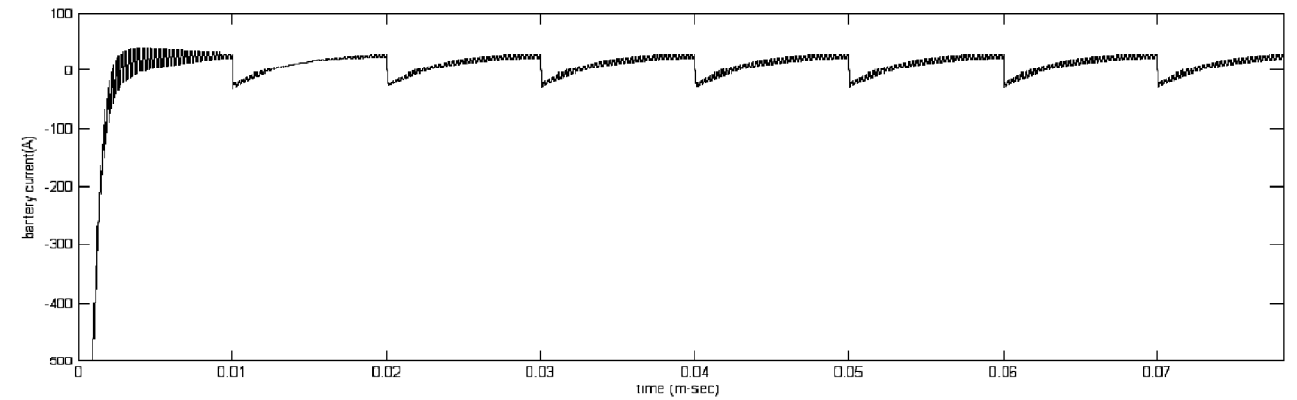

(g)

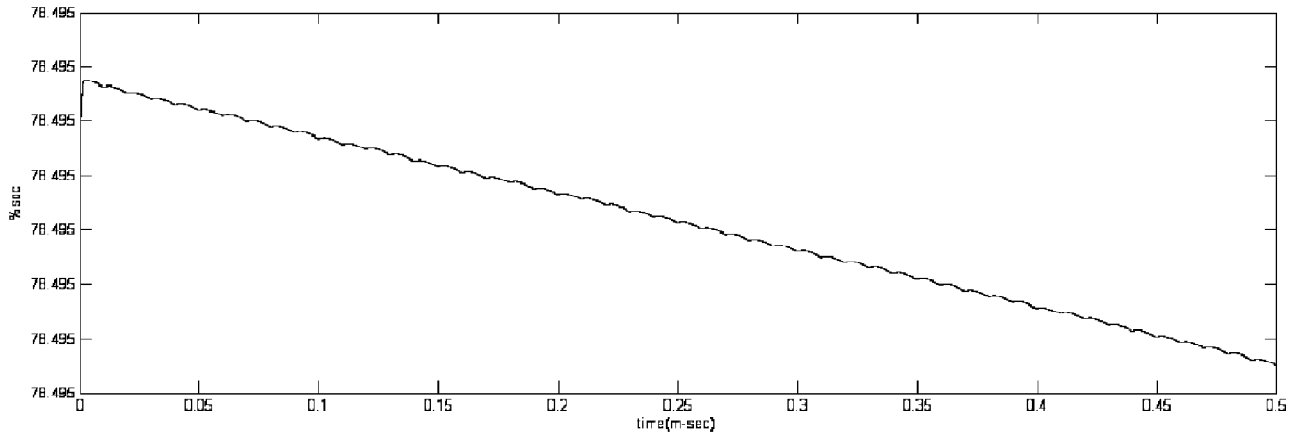

(h)

**Figure 6: Simulation results at constant wind speed for 1kW (a) torque (b) Speed of Rotor (c) Stator current (d) Output power (e) Load Switching Power (f) Battery voltage(g) Battery current (h) Percentage of charge**

**(B) Simulation Result of Wind Turbine at variable Wind Speed.**

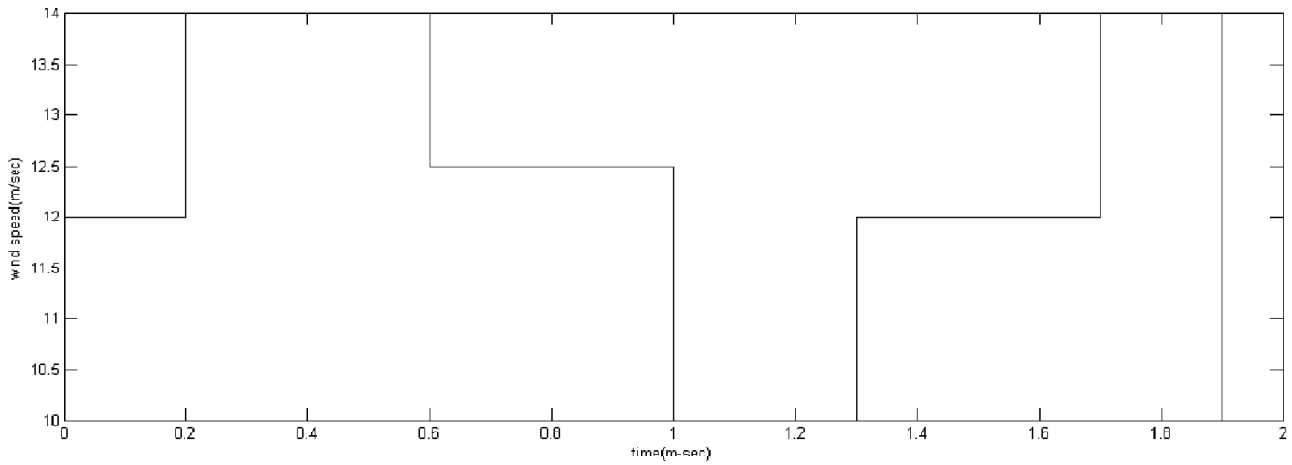

(a)

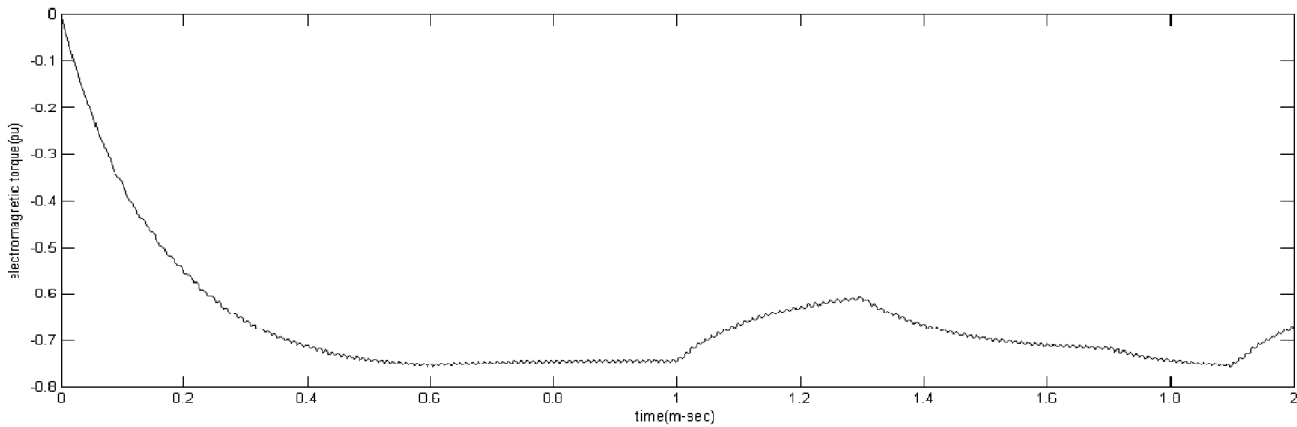

(b)



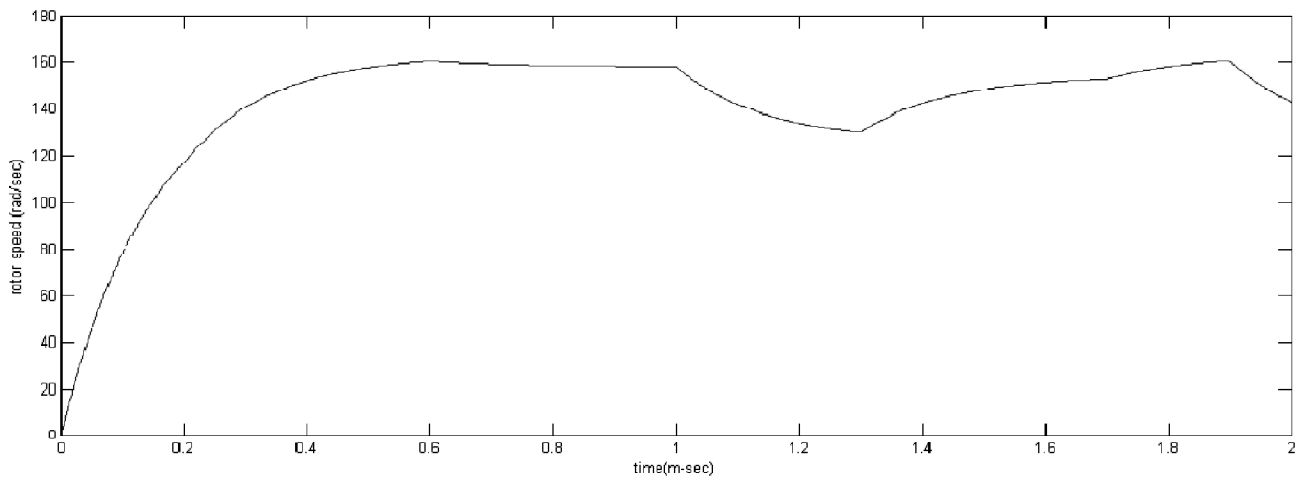

(c)

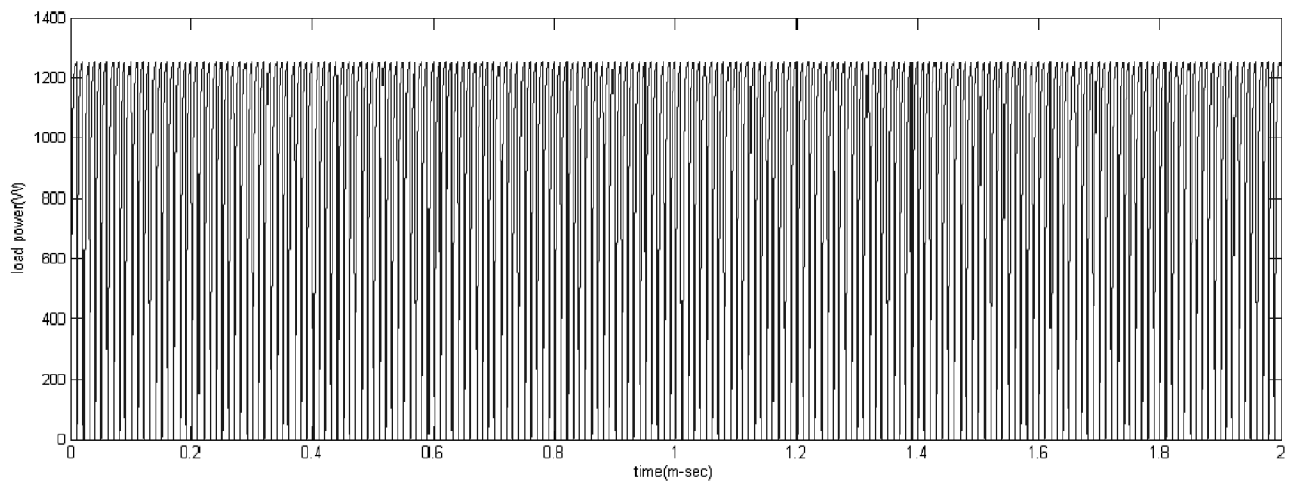

(d)

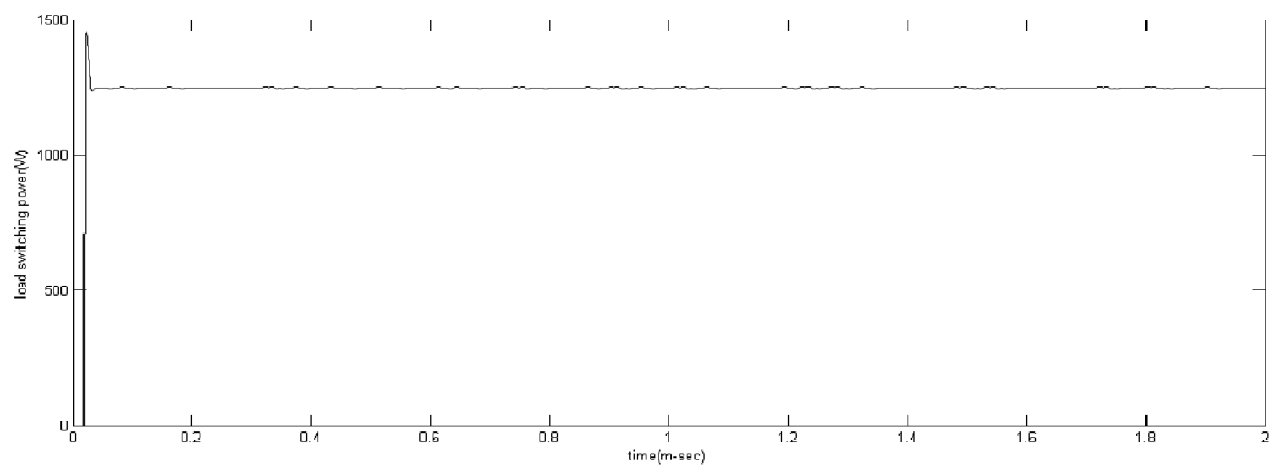

(e)

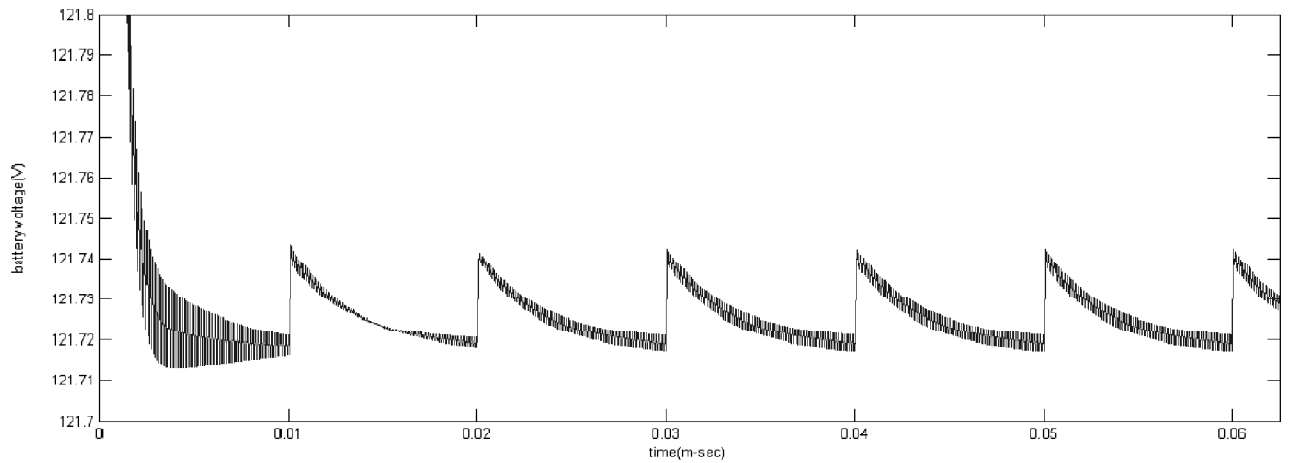

(f)

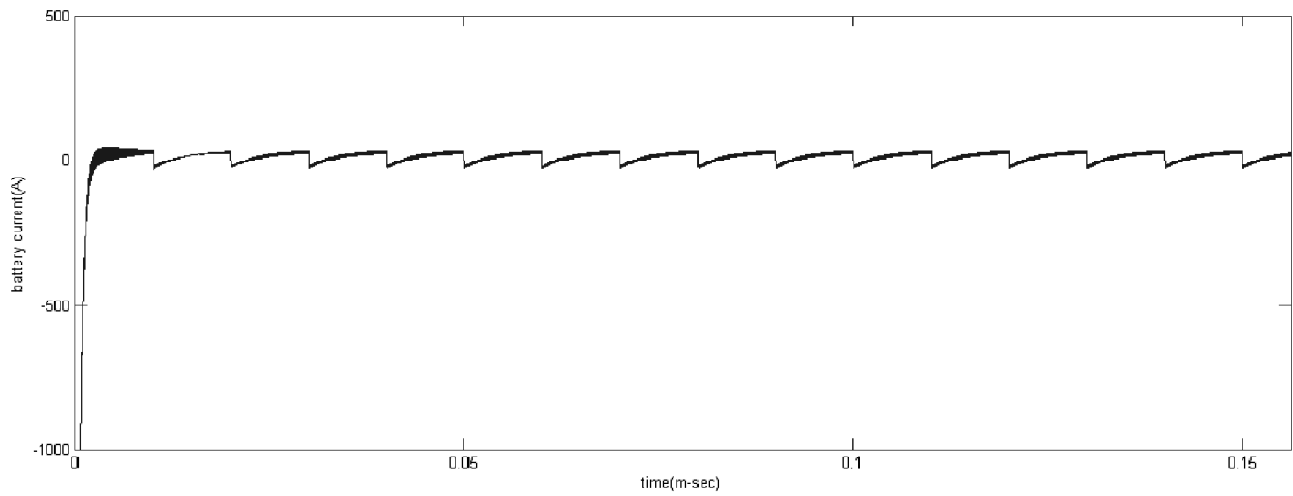

(g)

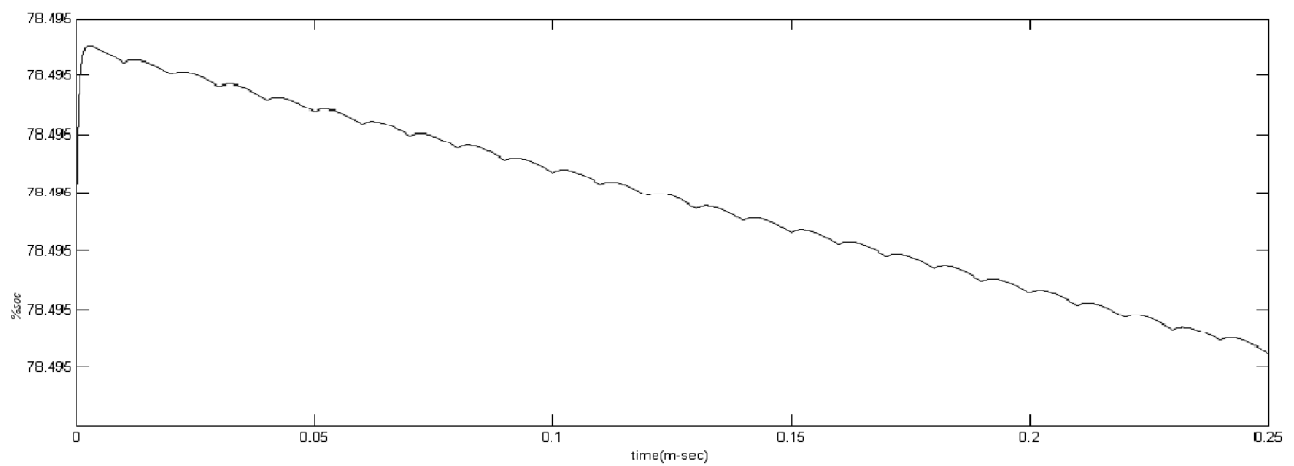

(h)

**Figure 7: Simulated results with Variable wind speed at 1kW (a) Variation of Wind Speed (b) torque (c) Stator current (d) output power (e) Load Switching Power (f) Battery voltage (g) Battery current (h) Percentage state of charge**

The developed control structure of 1KW aero generator was operate at constant wind speed 9 m/s and at variable wind speed at 0-14 m/s. The performance of the aero generator was shown at different load conditions. Here the load was switching at 1KW. Energy storage device is used for storing the energy during generating power was excess for the utilization of the load, and also giving power to the loads while the generating power was shortage for the utilization of load. Simulation of the circuit is performed using MATLAB.

From Fig. 6 (a) to Fig. 6 (h) shows the performance of wind turbine generator at 1KW load switching during the wind speed is constant. Fig. 7 (a) to Fig. 7 (h) shows the performance of wind turbine generator at 1KW switching during the speed of wind is variable. In the constant wind speed the generated energy will delivered to the load. If the load utilization power is smaller than generated power then the surplus power could be stored by the given battery rated 125V. Battery stage of charge was depict in Fig 6(f). In variable speed the generated power can't sufficient to operate the load without interruptions. So in this model, to operate the load a fuzzy logic was implemented to get high wind power during wind speed was varied. From the Fig. 7 (e) and Fig. 7(b) load switching power was stable even the wind is variable. In this, the power utilized by load is more than generated power, required power to load is supplied by the battery for uninterrupted the system. In accordance from above waveforms of the simulations gives behavior of standalone wind turbine generator along with energy storage systems during constant and variable wind speed conditions were analyzed.

## V. CONCLUSION

The control strategy developed on standalone aero generator along with storage systems has been analyzed. Here the storage system plays a vital function to steady the voltage in self-governing application. The energy generated by wind turbine sufficiently delivers to the loads by developed control technique. From the variable wind, the energy generated by turbine generator coupling was supply to the load. To avoid frequency mismatching between generator and the utility loads generated power would be converted to AC to DC using rectified circuit. The role of getting maximum energy from the wind fuzzy control was implementing to generate the switching signals to DC to DC converter. Its output from DC-DC converter delivers to load through the inverter. The load utilization power is more than the power generated then storage device will supply the power for remove the load interruptions. It is concluded that the developed control method for the stand- alone aero generator including by battery was achieve all the requirements to run the loads without discontinuity even though wind is varied.

## REFERENCES

- [1] Chenna Surendra, P. Sai Sampath Kumar "Control Strategy of Stand-Alone Wind Based Energy System for Small Scale Power Grid Applications", *IJRSE Trans.* Vol. 3. Iss 6, PP 242-251, June 2015.
- [2] Luminita Barote, Corneliu Marinescu, Marcian N. Cirstea, "Control Structure for Single-Phase Stand-Alone Wind-based Energy Sources", *IEEE Trans. Ind. Electronics*, vol. 60, No. 2, February 2013.
- [3] R. A. Mastromauro, M. Liserre, and A. Dell'Aquila, "Control issues in single-stage photovoltaic systems: MPPT, current and voltage control," *IEEE Trans. Ind. Informat.*, vol. 8, no. 2, pp. 241–254, May 2012.
- [4] C. Liu, K. T. Chau, and X. Zhang, "An efficient wind-photovoltaic hybrid generation system using doubly excited permanent-magnet brush-less machine," *IEEE Trans. Ind. Electron.*, vol. 57, no. 3, pp. 831–839, Mar. 2010.
- [5] M. P. Kazmierkowski, M. Jasinski, and G. Wrona, "DSP-based control of grid-connected power converters operating under grid distortions," *IEEE Trans. Ind. Informat.*, vol. 7, no. 2, pp. 204–211, May 2011.
- [6] P. Palensky and D. Dietrich, "Demand side management: Demand re-sponse, intelligent energy systems, and smart loads," *IEEE Trans. Ind. Informat.*, vol. 7, no. 3, pp. 381–388, Aug. 2011.
- [7] V. C. Gungor, D. Sahin, T. Kocak, S. Ergut, C. Buccella, C. Cecati, and P. Hancke, "Smart grid technologies: Communication technologies and standards," *IEEE Trans. Ind. Informat.*, vol. 7, no. 4, pp. 529–539, Nov. 2011.

- [8] S. Wencong, H. Eichi, Z. Wentz, and M.-Y. Chow, "A survey on the electrification of transportation in a smart grid environment," *IEEE Trans. Ind. Informat.*, vol. 8, no. 1, pp. 1–10, Feb. 2012.
- [9] R. Teodorescu, M. Lissere, and P. Rodriguez, *Grid Converter for Photo-voltaic and Wind Power Systems*. New York: Wiley, 2011.
- [10] E. Monmasson, L. Idkhajine, M. N. Cirstea, I. Bahri, A. Tisan, and W. Naouar, "FPGAs in industrial control applications," *IEEE Trans. Ind. Informat.*, vol. 7, no. 2, pp. 224–243, May 2011.
- [11] L. S Yang and T. J. Liang, "Analysis and implementation of a novel bidi-rectional DC–DC converter," *IEEE Trans. Ind. Electron.*, vol. 59, no. 1, pp. 422–434, Jan. 2012.
- [12] M. H. Nehrir, C. Wang, K. Strunz, H. Aki, R. Ramakumar, J. Bing, Miao, and Z. Salameh, "A review of hybrid renewable/ alternative en-ergy systems for electric power generation: Configurations, control, and applications," *IEEE*.