

A Novel Regenerative and Anti-Lock Braking Technique for Electric Vehicles

Sagar Maliye, Sudeendra kumar, Ayaskanta Swain, K.K. Mahapatra

Abstract: Sudden braking of vehicles traveling at higher velocities may lead to accidents due to wheel lock up. Anti-lock brake system (ABS) prevents wheel being locked up by using non-continuous braking. Most of the braking systems of modern vehicles incorporate ABS today. In the era of sustainable engineering, regenerative braking (RG) is a technique to save the energy in modern day electric and hybrid electric vehicles. It is challenge for engineers to develop control technique efficient functioning of both ABS and RG. In this paper, focus is on to develop holistic control strategy for ABS and RG together and to validate it experimentally. Slip ratio remains in safe range with functioning regenerative system saving 17% energy.

Keywords: Anti-lock; slip; buck-boost; regeneration; pulse width modulation.

1. INTRODUCTION

The climate change and energy crisis has driven governments around the world, to frame policy towards alternative fuels, and electric vehicles. Major economies in the world announced subsidies to accelerate usage of electric vehicles and alternative fuel.

Various factors like mileage and maintenance will drive consumer to turn towards electric vehicles and hybrid electric vehicles in post-recession era. Electric vehicle (EV) is driven by rechargeable battery and drive range of electric vehicle is short. Research to improve the driving mileage of electric vehicles is aggressively taken up. Regenerative braking is very important towards improving the mileage of the electric vehicles. Generally, regenerative braking is achieved through the electric motor, providing negative torque to wheels and the kinetic energy is used to recharge the batteries [9]. Kinetic energy can be used to recharge the batteries with the help of control algorithms and power electronics. Improvements in regenerative braking will help to improve the drive range from 8 to 25% [6] [7].

Another important aspect of braking systems in modern vehicles is Anti-lock Braking systems (ABS). ABS is a promising solution from last two decades to solve this problem instability during braking. ABS will address wheel lock-up and directional control of the vehicle.

One of the early attempts of designing a combined technique for both ABS and RG can be found in [8] and [9]. In [8], authors use the tire model, motor model and battery model to design coordinated control for both ABS and RG. A mathematical model for battery, motor and tire are derived and fuzzy logic based combined control design is proposed in [9]. This work is an extension to [9]. This work makes use of power electronics presented in [4] to develop integrated ABS and RG system. In [9], the fuzzy logic controller has got two inputs: slip ratio and state of charge (SOC) of the battery and one output variable: regenerative braking torque, which is controlled by duty cycle of PWM generated by fuzzy logic controller. In [9], more

priority is given to braking and regeneration occurs when slip ratio is safe. In this paper, an integrated controller for ABS and RG is proposed which generates two output signals for ABS and RG. The paper is organized as follows: Section II describes ABS and section III describes regenerative braking in detail. Section IV discusses control system and its implementation for integral control of ABS and regenerative braking. Section V describes results and analysis and finally section VI draws conclusions.

2. ANTI-LOCK BRAKING SYSTEM

ABS has become essential feature of brake system in modern vehicles. During severe braking situations, wheels will lock and have zero velocity, but velocity of vehicle mass cannot become zero as fast as wheel. The difference in the momentum between the vehicle mass and wheels will lead to instability and may lead to serious accidents and also, few other consequences are: loss of steering control and tire wear. A point obtained in which the tangential velocity of wheel and velocity of vehicle mass on road surface can be taken as slip ratio. In simple way, the ratio between tangential velocity of wheel and true ground velocity of vehicle is called slip ratio. This can be expressed as:

$$\lambda = \frac{V_g - V_t}{V_g} \tag{1}$$

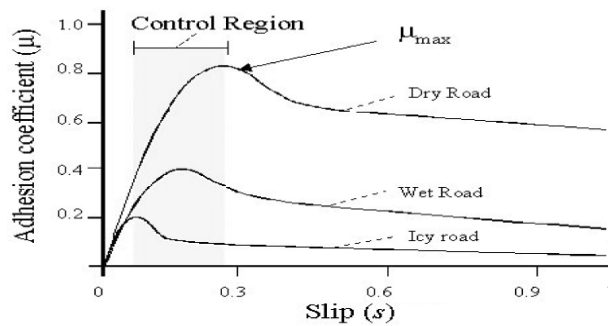

Figure 1: μ -s sample characteristics

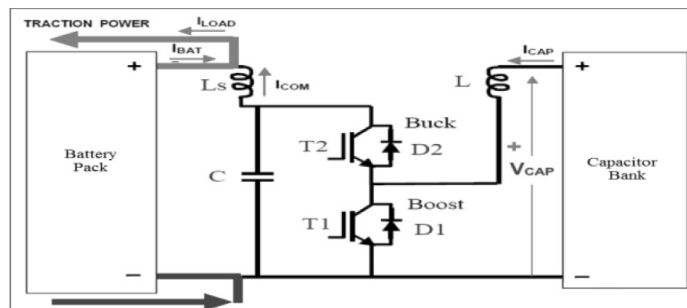

Figure 2: Regenerative braking circuit

Table 1
Values of μ and s for various road surfaces [1]

| Road Condition | Max adhesion coefficient | Optimum Slip |
|----------------|--------------------------|--------------|
| Dry Road | 0.85 | 0.35 |
| Wet Road | 0.4 | 0.2 |
| Icy Road | 0.2 | 0.1 |

V_g is circumferential velocity of braked wheel and V_t represents the vehicle road speed. The free rolling wheel will have 0% slip ratio and locked wheel will have 100% slip. Braking force (μ) or the adhesion co-efficient of braking force is measured in the direction of wheel and it depends on road surface, material used in the upper layer of tire, tire inflation pressure, depth of the thread, its pattern and overall wheel construction. The relationship between the braking effort and slip for different road conditions is shown in figure 1. The plot is divided into two zones: stable and unstable.

The shaded zone represents stable area. In this area, non-slip braking is possible. Balance is lost and wheel will lock in unstable areas. The stable slip ratio varies from 8% to 30% depending on road conditions.

During hard braking, slip ratio will be high and it leads to instability and upset the vehicle. ABS aims to apply brake to vehicle in the safe slip range. ABS is based on the principle of deferred braking. With conventional braking system, driver of vehicle can do deferred braking, and safely stop the vehicle. When vehicle is at high velocities, it is impossible for driver to do defer braking. So ABS should be implemented using microcomputer, to achieve deferred braking.

Adhesion coefficient μ is defined as ratio of tire brake force at the road interface (F_L) and normal load (F_z) acting on tire.

$$\mu = \frac{F_L}{F_z}$$

The objective of an Antilock Braking System (ABS) is to control the tractive force applied on the wheels in order to limit the slip, s , between the road surface and the tires, to operate within the stable control region of the μ -*slip* characteristics as shown in Fig.1 [3], [10]. Table 1 shows the typical values of slip at which the maximum adhesion coefficient is obtained, for different road conditions [8].

3. REGENERATIVE BRAKING

Regenerative braking is an energy recovery mechanism to save energy and to re-store the energy. Wastage of kinetic energy during braking is high in urban driving. The surplus energy available during braking state of electric motor can be recovered using regenerative braking. Surplus energy during braking state of motor can be used charge the capacitor banks. The advantages of regenerative braking are better fuel economy, soft braking and better control over braking [4], [5].

Brake controller controls the motor speed, based on speed of wheel. It also monitors the torque, rotational force. During braking the controller diverts the electricity from the motor to charge the capacitors. Another possible technique is diverting the current flowing from battery into motor to charge capacitors.

The braking controller takes care for maximum regenerative efficiency and constant regenerating current control. Controller also limit the maximum charging current in the range of 0.1C (C is the capacity of the battery) to prevent the damage of the battery. The controller will have it challenging time when running on long escarpment. Normally it takes long time for electric vehicle to come to halt. During this time, regenerative system will divert large amount of current towards battery, which may exceed 0.1C [2]. To avoid damage to the battery, ultra-capacitors can be used between regenerative system and battery. Ultra-capacitors can store 20 times more charge than general electrolytic capacitors.

As discussed earlier, it is challenge for researchers to develop control algorithms and power electronics for both ABS and regenerative braking without compromising the performance of either system. In this

paper, the specific focus is on design and development of control algorithm and electronic system, which address the requirement of both ABS and regenerative braking in electric vehicles.

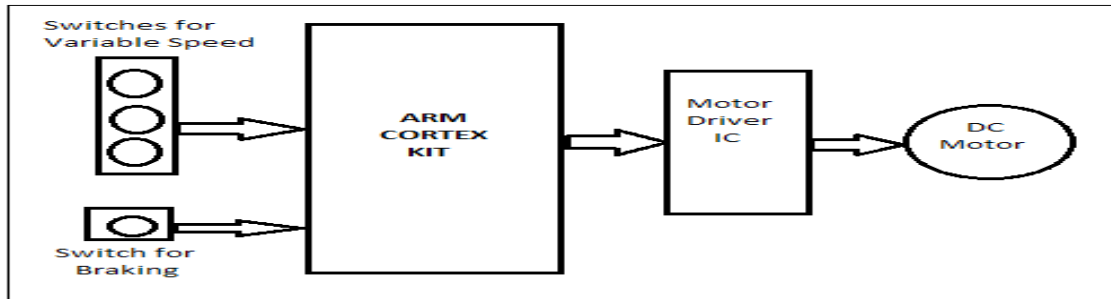

Figure 3: PWM generation circuit

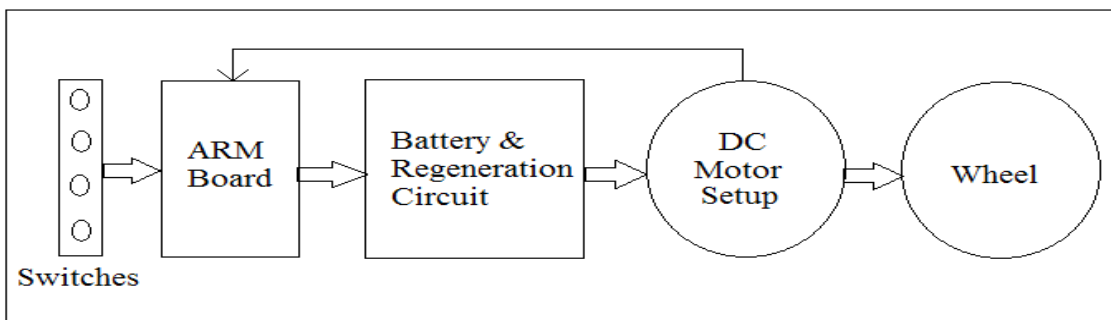

Figure 4: Block Diagram of Experimental setup

4. SIMULATION AND EXPERIMENTAL SETUP

A. Simulation of Regenerative circuit:

Simulation of regenerative circuit is discussed in this section. The circuit proposed by Dixon and others in [4] is used and integrated with ABS system. The circuit diagram is shown in figure 2 respectively. The regeneration circuit consists of lead acid battery with nominal voltage of 12 V and a capacity of 1.3 Ah. The ultra-capacitor bank connected stores the energy temporarily to charge the battery or to discharge to motor. Ultra-capacitors are connected in series, such that the total capacitance of bank will be higher value. The inductor L is taken of value of 10mH and L_s is equal to 1 μ H. The Capacitor C is of 470 μ F (with voltage rating of all capacitors is 35 V).

Basically regeneration circuit performs buck and boost operation. Buck operation takes place during deceleration, when brakes are applied. The boost operation takes place when vehicle is in acceleration. The Buck operation diverts the current going to the motor to capacitor bank. The operation of both buck and boost circuit is controlled through PWM signal generated by ARM microcontroller. When IGBT switch T2 is ON, the energy flows from battery to capacitor bank through this switch and inductor L stores some part of energy. When T2 switch OFF, the energy stored in L will flow into capacitor bank through diode D1.

The T1 is switched on and off by PWM signal. The duty cycle of PWM signal is controlled by ARM based microcontroller, such that the energy required to drive the motor is transferred from battery during boost operation. Capacitor bank provides the extra current required for motor during acceleration. Capacitor bank consists of ultra-capacitor which can charge and discharge at faster rate than normal capacitors, which are useful in regenerative braking circuits.

The figure 5 and figure 6 shows the simulation results of regenerative circuit. The buck operation of the circuit makes the capacitors to charge to higher voltage levels. Initial charge present in the capacitor bank is zero. Voltage will increase from zero to 11 volts at the end of third cycle of PWM (with 60% duty cycle). Voltage across the battery remains at 12 V and current is drawn from battery through the capacitor bank when IGBT is fed with PWM pulse. The amount of current drawn depends upon the on time of the PWM pulse. In boost operation (when motor draws more current), ultra-capacitor bank supplies the current stored in it. In simulation waveforms, it is visible that, voltage across capacitor bank decrease through successive cycles. In simulation, it is observed that voltage decreased in boost operation form 10 V to 5.5 V.

B. PWM generation circuit

The two major purpose of PWM circuit is to control the regenerative circuit and to generate the braking signal for the anti-lock brake system. When vehicle is in higher speeds, applying a sudden brakes lead to instability of vehicle and this may lead to accidents.

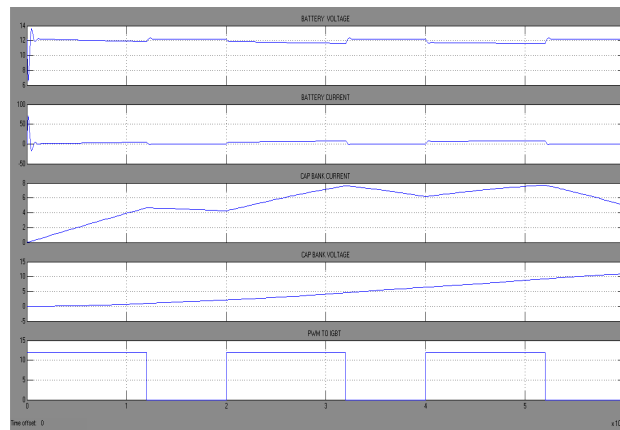

Figure 5: Waveform for Buck Cycle (Deceleration)

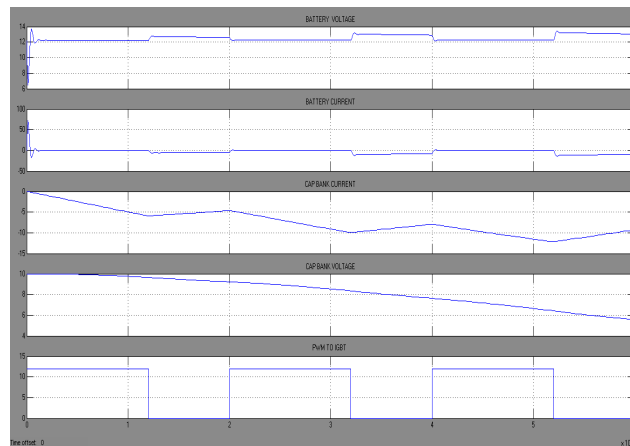

Figure 6: Waveform for Boost Cycle (Acceleration)

So ABS will work on the principle of deferred braking and maintains the slip ratio in the stable range. This avoids instability of vehicle and three speed switches operated by brake system set the duty of cycle of PWM. PWM pulse controls the current flow into the electric motor (which drives wheels of vehicle) and slows down the motor while braking, not allowing the wheels to get locked in the range of unsafe slip ratio. Vehicle will come to halt safely.

The functioning of regenerative circuit is also controlled using PWM. The amount of current flowing from capacitor bank to motor is determined by current sensors. Controller will vary the duty cycle of PWM pulse based on the current sensor input, to switch from boost to buck and vice versa. During braking, the current flowing into motor is diverted towards capacitor banks. When vehicle is in acceleration, more current from capacitor banks will flow towards motor. In the experimental setup, the PWM pulse for braking is applied is of 15Hz, i.e. the wheel experiences 15 cycles of PWM braking pattern in one second.

In the experimental setup, the PWM pulse for braking is applied is of 15Hz, i.e. the wheel experiences 15 cycles of PWM braking pattern in one second. Regenerative circuit requires PWM pulse for its operation. A block diagram of PWM circuit is shown in figure.5. PWM circuit consists of ARM Cortex- M3 STM32 microcontroller. This microcontroller has got dedicated programmable PWM generation module, which can generate PWM pulses with different duty cycles with more precision.

C. Experimental Setup

In the experimental setup, the PWM pulse for braking is applied is of 15Hz, i.e. the wheel experiences 15 cycles of PWM braking pattern in one second. Regenerative circuit requires PWM pulse for its operation. A block diagram of PWM circuit is shown in figure.3.

PWM circuit consists of ARM Cortex- M3 STM32 microcontroller. This microcontroller has got dedicated programmable PWM generation module, which can generate PWM pulses with different duty cycles with more precision. The experimental setup consists of regenerative circuit, ABS motor with control circuits, PWM driving circuit and STM32C ARM microcontroller evaluation board. The software running on the microcontroller will make use of timers to generate the PWM signal. The period of PWM pulse fed into IGBT's is 200 ms. The PWM pulse period used in simulation is 2ms.

The LABVIEW software is used to collect data from the circuit. The NI 9219 DAQ card can process the signals from +60 V to -60 V. DAQ card converts the analog values to digital values, these values will be displayed on the computer using DAQ assistant.

IGBT's used need more current and ARM microcontroller drives the non-inverting Op-Amp (LM 324) circuit which drives more current at the voltage of 10 to 12 V.

Microcontroller measures the slip ratio and controls the braking circuit to apply the brakes on motor appropriately. Simultaneously, PWM signals from microcontroller will drive regenerative circuit to perform buck or boost operation. During buck operation, unlike simulation results, the change in battery voltage is not instantaneous.

D. Control Technique

To control both ABS and RG, in [9], single output variable is used and which gave priority to ABS so that efficiency of RG reduced. In this control technique, controller will take the decision based on the look-up table stored in the memory to take decision. In this proposed control technique look-up table is formed based on the experimental observations, experience and expertise inputs to take control decision. The look-up table is shown in Table 2. In comparison with [9], the proposed technique will use two output PWM signals, one for ABS and another for RG. In [9], when slip ratio is unsafe, RG is off and ABS will be active. The single output coming from fuzzy controller is used to control the duty cycle of PWM and the PWM is used to control both the subsystems ABS and RG. In our proposed technique, which is an improvement to [9], we split the control signals for ABS and RG separately, so that RG is not switched off even when slip ratio is unsafe. The RG system will charge the batteries whenever brakes are applied if State of Charge (SOC) is low.

The energy stored in capacitor can be assessed by sensing the voltage across it. The voltage across the capacitor is controlled by PWM pulse applied to buck-boost converter after considering vehicle speed. The measurement of instantaneous capacitor bank voltage determines when the converter works as Boost or Buck.

As per the table 2, maximum braking is applied in safe region and minimum braking in the unsafe region of slip ratio as shown in figure 1. The regeneration control strategy is based on reference table 2. In table 2, percentage of charge on the capacitor bank represents amount of charge available in the bank.

The duty cycle of the PWM pulse for both ABS and regeneration is controlled by ARM microcontroller. It makes use of input signals: slip ratio, motor speed and amount of charge on capacitor. Based on the input values and by taking the look-up table values, the duty cycle of PWM-1 and PWM-2 is determined.

5. RESULTS

Buck operation of regenerative circuit diverts the current towards capacitor bank from motor. The voltage across the capacitor bank increases. The charge is stored in capacitor bank and it gets charged up to 11 V. During acceleration, Boost operation takes place in regenerative circuit. In this phase capacitor bank will lose charge and battery voltage will rise to 13.2 V.

After running the motor continuously for few hours and in between brakes are applied. Slip ratio and efficiency of regenerative braking circuit is tested. The two types of tests are conducted on the system: applying the brakes in regular intervals and randomly.

The waveforms obtained using DAQ assistant shows during that, ultra-capacitor bank will get charged up to 8.7 V. Total capacitance value of the capacitor bank used is 7.6 milli farads. The energy stored in the capacitor bank is given by:

$$E = \frac{1}{2} \times C \times V^2$$

Where E is the total energy stored in ultra-capacitor bank, C is the capacitance of the ultra-capacitor bank and V is the voltage across the ultra-capacitor bank. Therefore

$$E = \frac{1}{2} \times 7.6m \times 8.7^2 = 0.87 \text{ Joules}$$

The charge stored in ultra-capacitor bank is given by:

$$Q = C \times V = 7.6m \times 8.7 = 66.1 \text{ milli Coulomb}$$

The current of about 70 milli amperes is measured. The time required to charge the capacitor can be calculated as:

$$t = I \div Q = 70m \div 66.1m = 1.06 \text{ seconds}$$

The power can be calculated as:

$$P = E \div t = 0.287 \div 1.06 = 0.270 \text{ Watts}$$

With regenerative braking 0.27 Watts can be saved. Along with regenerative braking, the performance of ABS system is also evaluated. The ABS system maintains the slip ratio between 0.3 and 0.4, which is reasonably safe. By running the motor for 2 hours, it is observed that, with the designed control technique, 17% of energy can be saved with regenerative braking system. The earlier research in [9] reported 11% energy saving.

Table 2
Look-up to take control decision for ABS and RG

| <i>State of Charge (SOC)</i> | <i>Slip Ratio</i> | <i>PWM-1 for ABS (%)</i> | <i>PWM-2 for RG (%)</i> |
|------------------------------|-------------------|--------------------------|-------------------------|
| Very High (VH) (75-99) | 0.15-0.20 | 90 | Boost |
| | 0.20-0.25 | 85 | Boost |
| | 0.25-0.30 | 70 | Boost |
| | 0.30-0.35 | 55 | Boost |
| | 0.35-0.40 | 40 | Boost |
| | 0.40-0.45 | 25 | Boost |
| | 0.45-0.50 | 10 | Boost |
| High (H) (50-75) | 0.15-0.20 | 90 | Buck |
| | 0.20-0.25 | 85 | Buck |
| | 0.25-0.30 | 70 | Buck |
| | 0.30-0.35 | 55 | Buck |
| | 0.35-0.40 | 40 | Boost |
| | 0.40-0.45 | 25 | Boost |
| | 0.45-0.50 | 10 | Boost |
| Low (L) (25-50) | 0.15-0.20 | 90 | Buck |
| | 0.20-0.25 | 85 | Buck |
| | 0.25-0.30 | 70 | Boost |
| | 0.30-0.35 | 55 | Buck |
| | 0.35-0.40 | 40 | Buck |
| | 0.40-0.45 | 25 | Boost |
| | 0.45-0.50 | 10 | Boost |
| Very Low (VL) | 0.15-0.20 | 90 | Buck |
| | 0.20-0.25 | 85 | Buck |
| | 0.25-0.30 | 70 | Boost |
| | 0.30-0.35 | 55 | Buck |
| | 0.35-0.40 | 40 | Buck |
| | 0.40-0.45 | 25 | Boost |
| | 0.45-0.50 | 10 | Boost |

6. CONCLUSION

The look-up table based controller proposed considers slip ratio, State of Charge (SOC) and generates two control signals which decide the duty cycle of PWM pulse. The proposed system is experimentally validated. The proposed control technique for ABS and RG save 17% energy compared with ABS without regenerative system. Thus, both ABS and regenerative braking are functioning satisfactorily.

References

- [1] Khatun P, Bingham C M, Schofield N, Mellor P H; "Application of Fuzzy Control Algorithms for Electric Vehicle Antilock Braking/Traction Control Systems", *IEEE Transactions on Vehicular Technology*, Volume 52, pp. 1356-1364, Sept 2003.
- [2] Implementation of Fuzzy logic for an Anti-lock Brake system, David E Nelson, Rajab Challo, IEEE International Conference on Computational Cybernetics and Simulations, 1997.
- [3] Dixon J, Ortuzar M; "Regenerative Braking for an Electric Vehicle using Ultracapacitors and Buck-Boost Converter", *Aerospace and Electronic Systems Magazine*, vol 17, 2002, pp. 16-21.

-
- [4] Xin Z, Xiufang Y; “Study of control logic for Automobile Anti-lock Braking System”, International Conference on Intelligent Computation Technology and Automation. Volume: 1, 2008, pp. 493-497.
 - [5] Xu C, Sha L, Cheng K, “Simulation of Integrated Controller of the Anti-Lock Braking System”, 3rd International Conference on Power Electronics Systems 2009, pp. 1-3.
 - [6] Tanelli M, Piroddi L; “Real time identification of tire- road friction conditions”, *IET Journal* 2008, Volume: 3, Issue: 7, pp. 891-906.
 - [7] Sudeendra kumar, Leslin varghese, K.K.Mahapatra, Fuzzy logic based integrated control of anti lock brake system and collision avoidance system, IEEE conference on Industrial Technology-2009, Gippsland University, Australia.
 - [8] Cheng-Hu Chen, Wen-Chun chi, Ming Yang Cheng, Regenerative braking for light weight electric vechicles, IEEE PEDS-2011, Singapore.
 - [9] D. Peng, Y. Zhang, C.L. Yin and J.W. Zhang, “Combined Control of a Regenerative Braking and Antilock Braking system for Hybrid Electric Vehicles”, *International Journal of Automotive Technology*, Vol. 9, No. 6, pp. 749-757 (2008), Springer.
 - [10] Reif Konrad, “Brakes, Brake Control and Driver Assistance Systems”, *Bosch Automotive* -2014.

