

MODELING THE DYNAMICS OF HEPTADS' EFFECT EVAPORATOR SYSTEM IN THE KRAFT RECOVERY PROCESSES

Om Prakash Verma^{*}, Toufiq Haji Mohammed^{**}, Shubham Mangal^{***}, Gaurav Manik^{****}

Abstract: The performance of the multi-stage evaporator (MSE) system used in the pulp and paper industry for the Kraft recovery process may vary significantly during the transient time of start-up, shutdown, load changes and rejections, troubleshooting, etc. This makes it quite imperative for a process engineer to know the transient behavior of the system under operation. Although, the steady-state models for the MSE system have been analyzed quite exhaustively by the researchers in the past but the dynamic model has not been extensively investigated. The purpose of the paper is to develop and present a detailed dynamic model for the study of transient behavior of the evaporator unit with varying process designs. A heptads' effect evaporator system with the backward feed flow configuration has been considered for the dynamic modeling in the present work. Some important and pertinent energy saving operating strategies such as live steam split, liquor feed split, feed pre-heating and their hybrids, have been incorporated in the process design. The systematically evaluated material and heat balance equations evolve into different transient models with a set of nonlinear first order differential equations. The finally derived model equations may be conveniently simulated so that the performance of process control strategies could be compared and an optimized operating strategy be screened for use by industry under different operating conditions without disturbing the paper mill production and without imperiling the equipment.

Key Words: Multi-effect evaporator; backward feed flow sequence; steam split; liquor feed split; pre-heating of liquor feed; dynamic model

1. INTRODUCTION

Multi-stage evaporators (MSE) systems are highly energy intensive systems employed in the process industries to concentrate the weak liquors and these constitute the most integral part of the unit operations [1]. For example, weak black liquor, sugar cane juice, milk and several other types of fruit juices are concentrated in pulp and paper industry, sugar industry, dairy industry and food processing industry. A large amount of heat energy in the form of steam is consumed to concentrate the less concentrated liquors through evaporation and this makes the evaporation system one of the most energy consumed unit operation, specifically in pulp and paper industry [2].

* Research Scholar, Department of Polymer and Process Engineering, Indian Institute of Technology Roorkee, India
Email: opiitroorkee@gmail.com

** M. Tech. Integrated students, Department of Polymer and Process Engineering, Indian Institute of Technology Roorkee, India
Email: toufiq2t@gmail.com

*** M. Tech. Integrated students, Department of Polymer and Process Engineering, Indian Institute of Technology Roorkee, India
Email: mangalshubham161@gmail.com

**** Assistant Professor, Department of Polymer and Process Engineering, Indian Institute of Technology Roorkee, India; Currently at Asian Institute of Technology (AIT), Klong Luang, Pathumthani, Thailand, as Visiting Faculty
Email: manikfpt@iitr.ac.in; gaurav@ait.asia

Therefore, there is a need to retain the energy and improve the efficiency in the evaporation operation. In order to reduce the steam consumption (SC) or increase the steam economy (SE), many of the researchers [3]-[11] have developed different operating strategies models for MSE system and have solved the models by different mathematical approaches.

The optimal performances of the MSE system, either SE or SC are achieved only after the tight control of output concentration and level of the black liquor inside each effect. In order to solve the problems of transient behavior such as start-up, shutdown, load rejection, troubleshooting and produce a relatively constant output during the recovery process dynamic modeling of the MSE system has been derived. In order to analyze the mathematics of MSE system, several research articles have reported the effect of steady-state solutions on SE and SC of the MSE system. Few of noteworthy efforts in this area are made by [12]-[21]. However, the dynamic modeling and behavior of the MSE system has not been extensively explored and reported. A few of the research citations available in this area are: [22]-[25], [8], [26]. In [27], simulation model of multi effect stack evaporator have developed to predict the transient behavior in distillation plant. In [28], a nonlinear regulator have been designed using Riemannian geometric approach and applied it to double effect evaporator unit. A differential geometric nonlinear controller have applied to input-output linearization on the single effect evaporative unit to concentrate weak liquor burning process in an alumina refinery by [29]. In [30], a nonlinear model predictive control have successfully applied and removed the offset to four effect evaporator system. In [31], a nonlinear model have been developed for three effect falling film evaporator used in food industry and then applied cascade control algorithm for the analysis.

Nomenclature			
A	Heat transfer area (m^2)	x	Concentration of liquor
h	Enthalpy of black liquor (kJ/h)	y	Fresh steam split fraction
h_c	Enthalpy of condensate (kJ/h)	SC	Steam consumption (kg/s)
H	Enthalpy of vapor (kJ/h)	SE	Steam economy
k	Liquor feed fraction	<i>Subscripts</i>	
L	Feed flow rate (kg/s)	i	Effect number
m	Vapor fraction sent to pre-heater	f	Liquor feed
M	Mass hold-up in each effect	p	Liquor product
S	Fresh steam flow rate (kg/s)	<i>Greek Letters</i>	
T	Vapor body temperature ($^{\circ}C$)	λ	Latent heat of vaporization (kJ/kg)
U	Overall heat transfer coefficient ($kW/m^2\ ^{\circ}C$)	Δ	Change/difference
V	Vapor flow (kg/s)		

In the light of the above background, this work is intended to explore and present the dynamic modeling of a backward feed flow configuration with possible permutation operating strategies for a heptads' effect evaporator (HEE) system used in Kraft recovery process of Indian pulp and paper industries. The operating strategies used in the current work have been explained earlier in the work presented for the steady state analysis [11].

2. DYNAMIC MODELING OF HEPTADS' EFFECT EVAPORATOR SYSTEM

2.1 Process description

Multi-stage evaporative unit is used to concentrate weak black liquor containing dissolved and suspended organic solids from pulp and paper industry. The system considered in the present work

and the relevant operating data are captured from a paper mill located nearby in Saharanpur, India. Figure (1) shows the flow diagram of backward feed MSE system which consists of heptads' effects. The directionally opposite flow of liquor feed and fresh steam/vapor characterizes the backward feed flow configuration. The different possible add-on operating strategies to backward flow have been considered to configure the modeling of the HEE system and these have been tabulated in Table 1.

Table 1
Description of the proposed model configurations:

Model Name	Configuration Characteristic
Backward feed (Model-A)	Liquor fed to seventh effect and steam to first effect
Backward feed with steam split (Model-B)	Liquor fed to seventh effect and steam split to first and second effect with split ratio y
Backward feed with feed split (Model-C)	Liquor fed to seventh and sixth effect simultaneously with feed ratio k and steam fed to first effect
Backward feed with feed preheating (Model-D)	Liquor fed to seventh effect and steam to first effect, two pre-heater installed to concentrate black liquor before feeding to HEE (PH-1 & PH-2), m , fraction of vapor sent from sixth and seventh effect to preheater
Backward feed coupled with feed and steam split (Model-E)	Liquor fed to seventh and sixth effect simultaneously with feed ratio k and steam split to first and second effect with split ratio y
Backward feed coupled with steam split and feed preheating (Model-F)	Liquor fed to seventh and sixth effect and steam split simultaneously in first and second effect with split ratio y . Pre-heater used to concentrate the incoming feed
Backward feed coupled with feed split, steam split and feed Preheating (Model-G)	Liquor fed to seventh and sixth effect simultaneously with feed ratio k and steam split to first and second effect with split ratio y . Pre-heater used to concentrate the feed liquor with fraction m of vapor sent to pre-heater from sixth and seventh effect

The base of operating strategies is decided with the variations of fresh steam supplied and liquor feed to MSE system. If the fresh steam is supplied only to first effect evaporator unit to concentrate the black liquor entering from the subsequent effect, i.e., from the second effect and the vapor produced at the second effect is further used to next effect as a heat source to concentrate the weak black liquor. The black liquor is simply fed at last effect then such an operation is considered here as the base case of the backward feed configuration Model-A.

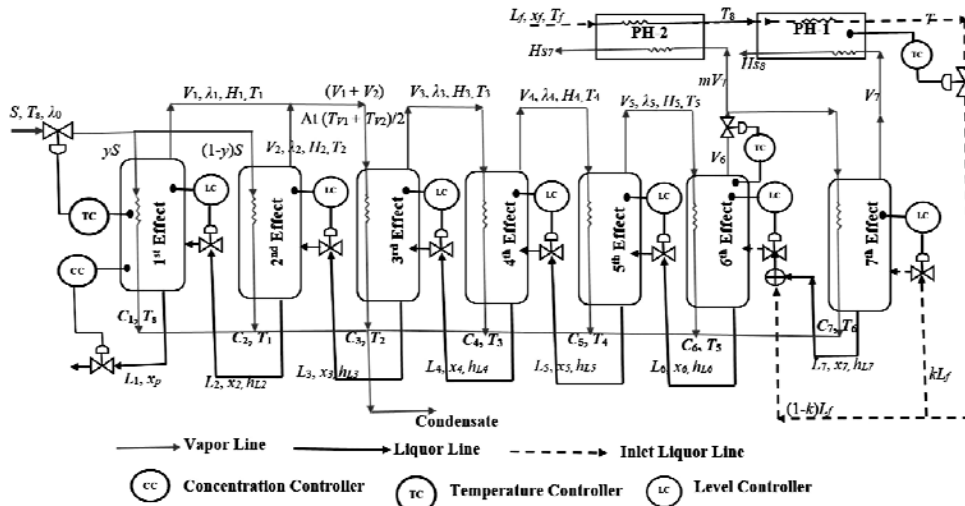

Figure 1 Backward feed coupled with steam, feed split and pre-heater HEE system

In the second model, Model-B, the fresh steam of flow rate, V_1 , is supplied to the system but is split into first and second effects with split fraction, y , and steam produced from both first and second effects are combined together and sent to third effect as a heat source as shown in the Figure (1). The vapor produced at third effect is used as a heat source to concentrate the black liquor for next effect and so on. The weak black liquor, L_f , is fed to the last effect (seventh effect) similar to Model-A. The concentrated black liquor exit at seventh effect, L_7 , as a product is further sent in backward direction i.e. to sixth effect to concentrate more and more and so on.

For the next model, Model-C, liquor fed to the last effect is split in between sixth and seventh effect with split fraction, k , while all the other conditions remain same as in base case Model-A.

Model-D introduces the concepts of two-preheaters as illustrated in previous literature [32], PH-1 and PH-2 before the black liquor fed to MSE system for the concentration. These two-preheaters is used preheat the black liquor before it is fed to the HEE system. The obtained preheated liquor through PH-1 and PH-2 is sent to last effect and then in backward direction similar to base case, Model-A. These two preheater PH-1 and PH-2 utilized the enthalpy of vapor produced at sixth effect with fraction, m , and the amount of vapor produced at last effect as illustrated in Figure (1). Hence, the un-concentrated black liquor temperature increases by $\Delta T_1 (= T_8 - T_0)$ at PH-1 and by $\Delta T_2 (= T - T_8)$ at PH-2. The amount of fresh steam is supplied at only first effect with the same direction similar to Model-A.

Model-E combines both the steam-/feed- split arrangements at first two and last two effects with fraction y and k respectively. In this case, the fresh steam V_1 is split into first and second effects with split fraction, y , similar to Model-B and at last two, sixth and seventh effects, the weak black liquor is fed with the split fraction, k as discussed in Model-C.

In the Model-F operation, the characteristics of Model-B and Model-D are inherited in which the fresh steam is split amongst the first and second effects with split fraction, y , and two preheater PH-1 and PH-2 preheat feed before it is fed to the HEE system.

Finally, Model-G combines all the operations mentioned earlier: a steam split operation as in Model-B with split fraction, y , a feed split operation as in Model-C with split fraction k and preheating operation (using PH-1 and PH-2) as in Model-D as illustrated in Figure (1).

2.2 Dynamic modeling of HEE system

The basis for the approach used for the dynamic modeling of the heptads' effect evaporator system has been grasped from the previous work [33]. They developed a dynamic model for two effect evaporator used to concentrate tomato paste and studied open loop process behavior. Further, they have proposed three multi loop control schemes to track the set points and disturbance rejection, namely Proportional-Integral controller (PI), gain scheduled PI and nonlinear PI. A block diagram representation of the HEE system has been illustrated in Figure (1) which shows how the sub-systems relate to each other. Some of the assumptions made to model the dynamic modeling of the HEE system for concentrating the weak black liquor are listed below:

Mass accumulation holdup is only in the liquid phase and appears at HEE separator side but not inside the evaporator shell.

- (i) Heat loss to the surrounding is negligible.
- (ii) Composition and temperature variation is negligible in each effects.
- (iii) Boiling point rise is negligible.

- (iv) Correlations of latent heat of vaporization and condensation are temperature dependent but the enthalpy of black liquor varied with temperature and concentration.
- (v) Black liquor and vapor produced at each effect are in phase equilibrium.

Dynamics of base case: Backward feed flow (Model-A)

A total mass balance equation for the i^{th} effect of HEE system incorporated with base case of the backward feed flow (Model-A) is given by Equation (1)

$$\frac{dM_i}{dt} = L_{i+1} - L_i - V_i \quad (1)$$

A total component mass balance equation for first effect of HEE system is given by Equation (2)

$$\frac{d(M_1 x_p)}{dt} = L_2 x_2 - L_1 x_p \quad (2)$$

$$M_1 \frac{dx_p}{dt} + x_p \frac{dM_1}{dt} = L_2 x_2 - L_1 x_p \quad (3)$$

$$M_1 \frac{dx_p}{dt} = L_2 x_2 - L_1 x_p - x_p (L_2 - L_1 - V_1) \quad (4)$$

After the simplification and rearrangements,

$$\frac{dx_p}{dt} = \frac{L_2(x_2 - x_p) + x_p V_1}{M_1} \quad (5)$$

The final generalized component mass balance obtained in Equation (5) is

$$\frac{dx_i}{dt} = \frac{L_{i+1}(x_{i+1} - x_i) + x_i V_i}{M_i} \quad (6)$$

The fresh steam flow rate to the first effect of HEE system is obtained through the energy balance as given in Equation (7)

$$S\lambda_0 = U_1 A_1 (T_s - T_1) \Rightarrow S = \frac{U_1 A_1 (T_s - T_1)}{\lambda_0} \quad (7)$$

For the i^{th} effect,

$$V_i = \frac{U_{i+1} A_{i+1} (T_i - T_{i+1})}{\lambda_i} \quad (8)$$

The energy balance equation for the first effect is derived below from Equations (9) - (12)

$$\frac{d[M_1 h(T_1, x_p)]}{dt} = L_2 h(T_2, x_2) + S\lambda_0 - L_1 h(T_1, x_p) - V_1 H(T_1) \quad (9)$$

Solving the Equation (9),

$$M_1 \frac{d[h(T_1, x_p)]}{dt} + h(T_1, x_p) \frac{dM_1}{dt} = L_2 h(T_2, x_2) + S\lambda_0 - L_1 h(T_1, x_p) - V_1 H(T_1) \quad (10)$$

After simplification, rearrangements and substituting the value of $\frac{dM_1}{dt}$ and $S\lambda_0$ in Equation (10),

$$\frac{d[h(T_1, x_p)]}{dt} = \frac{L_2 [h(T_2, x_2) - h(T_1, x_p)] + U_1 A_1 (T_s - T_1) - V_1 [H(T_1) - H(T_2, x_2)]}{M_1} \quad (11)$$

For the i^{th} effect,

$$\frac{d[h(T_i, x_i)]}{dt} = \frac{L_{i+1}[h(T_{i+1}, x_{i+1}) - h(T_i, x_i)] + U_i A_i (T_i - T_{i+1}) - V_i [H(T_i) - H(T_i, x_i)]}{M_i} \quad (12)$$

In the previous work, Bhargava et al. (2008) have shown that the correlations for enthalpy of black liquor, h_L , is a function of the temperature of the liquor as well as concentration of the black liquor. Verma et al. (2016) have developed the correlations for the latent heat of vaporization (λ), enthalpy of vapor (H) and enthalpy of condensate (h_c) and found that these parameters are only functions of temperature of vapor. The obtained correlations are presented here in Equations (13) - (16). We employ these correlations developed earlier to complete the modeling of proposed systems for the steady state analysis of SE and SC.

$$\lambda_i = -0.003857T_i^2 - 2.069T_i + 2497 \quad (13)$$

$$H_i = -0.0002045T_i^2 + 1.677T_i + 2507 \quad (14)$$

$$h_{c,i} = 0.001364T_i^2 + 4.15T - 2.24 \quad (15)$$

$$h_{L,i} = (4.187 - 2.26098x_i)T_{L_i} \quad (16)$$

Using the above correlations, the energy balance Equation (11) for the first effect is written as

$$\frac{d[4.187 - 2.26098x_p]T_1}{dt} = \frac{L_2[\{(4.187 - 2.26098x_2)T_2\} - \{(4.187 - 2.26098x_p)T_1\}] + U_1 A_1 (T_s - T_1) - V_1 [H(T_1) - h(T_1, x_p)]}{M_1} \quad (17)$$

$$\frac{dT_1}{dt} = \frac{L_2[h(T_2, x_2) - h(T_1, x_p)] + U_1 A_1 (T_s - T_1) - V_1 [H(T_1) - h(T_1, x_p)]}{M_1(4.187 - 2.26098x_p)} \quad (18)$$

For the second effect,

$$\frac{d[4.187 - 2.26098x_2]T_2}{dt} = \frac{L_3[h(T_3, x_3) - h(T_2, x_2)] + U_2 A_2 (T_1 - T_2) - V_2 [H(T_2) - h(T_2, x_2)]}{M_2} \quad (19)$$

After solving the final form of equation, we get

$$\frac{dT_2}{dt} = \frac{L_3[h(T_3, x_3) - h(T_2, x_2)] + U_2 A_2 (T_1 - T_2) - V_2 [H(T_2) - h(T_2, x_2)] + 2.261T_2 [L_3(x_3 - x_2) + V_2 x_2]}{M_2(4.187 - 2.26098x_2)} \quad (20)$$

For third to sixth effects, the generalized equation is

$$\frac{dT_i}{dt} = \frac{L_{i+1}[h(T_{i+1}, x_{i+1}) - h(T_i, x_i)] + U_i A_i (T_{i-1} - T_i) - V_i [H(T_i) - h(T_i, x_{i+1})] + 2.261T_i [L_{i+1}(x_{i+1} - x_i) + V_i x_i]}{M_i(4.187 - 2.26098x_i)} \quad (21)$$

Where, $i = 3, 4, \dots, 6$.

For the last effect,

$$\frac{dT_7}{dt} = \frac{L_7[h(T_7, x_7) - h(T_7, x_7)] + U_7 A_7 (T_7 - T_7) - V_7 [H(T_7) - h(T_7, x_7)] + 2.261T_7 [L_7(x_7 - x_7) + V_7 x_7]}{M_7(4.187 - 2.26098x_7)} \quad (22)$$

Dynamics of backward feed flow with steam split operation (Model-B)

This operation is incorporated with steam split with split fraction, y and $(1-y)$ in first two effects, and therefore, some of the equations and the dynamic behavior get modified. The total mass balance equation remains the same as in Equation (1), i.e. for the i^{th} effect,

$$\frac{dM_i}{dt} = L_{i+1} - L_i - V_i \quad (23)$$

The solid mass balance equation for the i^{th} effect after the simplification is

$$\frac{dx_i}{dt} = \frac{L_{i+1}(x_{i+1} - x_i) + x_i V_i}{M_i} \quad (24)$$

The fresh steam flow rate to the first and second effects of HEE system is obtained through the energy balance as given in Equation (25) below-

$$yS\lambda_0 = U_1 A_1 (T_s - T_1) \text{ and } (1-y)S\lambda_0 = U_2 A_2 (T_s - T_2) \text{ respectively} \quad (25)$$

For the third effect heat transfer rate is given by Equation (26),

$$(V_1 + V_2)(\lambda_{T_1} + \lambda_{T_2}) = U_3 A_3 (T_2 - T_3) \quad (26)$$

For the i^{th} effect,

$$V_i \lambda_i = U_{i+1} A_{i+1} (T_i - T_{i+1}) \quad (27)$$

Now, the energy balance equation for the first to third effects are as presented in Equations (28)–(30) and for the next fourth to seventh effects dynamics remain as in base case Model-A.

$$\frac{dh(T_1, x_p)}{dt} = \frac{L_2[h(T_2, x_2) - h(T_1, x_p)] + yU_1 A_1 (T_s - T_1) - V_1[H(T_1) - h(T_1, x_p)]}{M_1} \quad (28)$$

$$\frac{dh(T_2, x_2)}{dt} = \frac{L_3[h(T_3, x_3) - h(T_2, x_2)] + (1-y)U_2 A_2 (T_s - T_2) - V_2[H(T_2) - h(T_2, x_2)]}{M_2} \quad (29)$$

$$\frac{dh(T_3, x_3)}{dt} = \frac{L_4[h(T_4, x_4) - h(T_3, x_3)] + U_3 A_3 \left(\frac{T_{V1} - T_{V2}}{2} - T_3\right) - V_3[H(T_3) - h(T_3, x_3)]}{M_3} \quad (30)$$

After using the above correlations of the latent heat of vaporization (λ), enthalpy of vapor (H) and enthalpy of black liquor (h_L), the energy balance equations after the simplification for the first to third effects are written by Equations (31) - (33). The remaining transient equations remain the same as for the base Model-A.

$$\frac{dT_1}{dt} = \frac{L_2[h(T_2, x_2) - h(T_1, x_p)] + yU_1 A_1 (T_s - T_1) - V_1[H(T_1) - h(T_1, x_p)]}{M_1(4.187 - 2.26098x_p)} \quad (31)$$

$$\frac{dT_2}{dt} = \frac{L_3[h(T_3, x_3) - h(T_2, x_2)] + (1-y)U_2 A_2 (T_s - T_2) - V_2[H(T_2) - h(T_2, x_2)] + 2.26098T_2[L_3(x_3 - x_2) + V_2x_2]}{M_2(4.187 - 2.26098x_2)} \quad (32)$$

$$\frac{dT_3}{dt} = \frac{L_4[h(T_4, x_4) - h(T_3, x_3)] + U_3 A_3 \left(\frac{T_{V1} + T_{V2}}{2} - T_3\right) - V_3[H(T_3) - h(T_3, x_3)] + 2.26098T_3[L_4(x_4 - x_3) + V_3x_3]}{M_3(4.187 - 2.26098x_3)} \quad (33)$$

Dynamics of backward feed flow with feed split operation (Model-C)

The dynamic equation of this operation is similar to base case Model-A. However, due to inclusion of liquor feed split in fraction, k and $(1-k)$ in seventh and sixth effects, the equations of last two effects gets modified. The total mass balances for the sixth and seventh effects yields-

$$\frac{dM_6}{dt} = L_7 + (1-k)L_f - L_6 - V_6 \quad (34)$$

$$\frac{dM_7}{dt} = kL_f + L_7 - V_7 \quad (35)$$

The component mass balance for the sixth and seventh effects, after simplification and rearrangement are-

$$\frac{dx_6}{dt} = \frac{(1-k)L_f(x_f - x_6) + L_7(x_7 - x_6) + V_6x_6}{M_6} \quad (36)$$

$$\frac{dx_7}{dt} = \frac{kL_f(x_f - x_7) + V_7x_7}{M_7} \quad (37)$$

Similarly, heat transfer energy balance for the sixth and seventh effects are-

$$V_5\lambda_5 = U_6A_6(T_5 - T_6) \quad (38)$$

$$V_6\lambda_6 = U_7A_7(T_6 - T_7) \quad (39)$$

The energy balance equation for the sixth and seventh effects are shown in Equations (40) - (41).

$$\frac{d(T_6, x_6)}{dt} = \frac{L_7[h(T_7, x_7) - h(T_6, x_6)] + (1-k)L_f[h_f - h(T_6, x_6)] + U_6A_6(T_6 - T_7) - V_6[H(T_6) - h(T_6, x_6)]}{M_6} \quad (40)$$

$$\frac{d(T_7, x_7)}{dt} = \frac{kL_f[h_f - h(T_7, x_7)] + U_7A_7(T_7 - T_f) - V_7[H(T_7) - h(T_7, x_7)]}{M_7} \quad (41)$$

After using the correlations of the latent heat of vaporization (λ), enthalpy of vapor (H) and enthalpy of black liquor (h_L), the energy balance equations after simplification for the sixth and seventh effects attain the form of Equations (42) - (43) given below:

$$\frac{dT_6}{dt} = \frac{L_7[h(T_7, x_7) - h(T_6, x_6)] + (1-k)L_f[h_f - h(T_6, x_6)] + U_6A_6(T_6 - T_7) - V_6[H(T_6) - h(T_6, x_6)] + 2.26098T_6[(1-k)L_f(x_f - x_6) + L_7(x_7 - x_6) + V_6x_6]}{M_6(4.187 - 2.26098x_6)} \quad (42)$$

$$\frac{dT_7}{dt} = \frac{kL_f[h_f - h(T_7, x_7)] + U_7A_7(T_7 - T_f) - V_7[H(T_7) - h(T_7, x_7)] + 2.26098T_7[kL_f(x_f - x_7) + V_7x_7]}{M_7(4.187 - 2.26098x_7)} \quad (43)$$

The remaining dynamics and relevant equations remain the same as in base case Model-A.

Dynamics of backward feed flow with feed preheating operation (Model-D)

Model-D is feed preheating operation incorporated in the base backward feed flow configuration. Therefore, the dynamics of Model-D is modified at last two effects and remain the same for first to fifth stage.

The total mass balance for the sixth and seventh effects are given by Equations (44) - (45).

$$\frac{dM_6}{dt} = L_7 - L_6 - V_6 \quad (44)$$

$$\frac{dM_7}{dt} = L_f - L_7 - V_7 \quad (45)$$

The component mass balance for the last two sixth and seventh effects after simplification and rearrangement are

$$\frac{dx_6}{dt} = \frac{L_7(x_7 - x_6) + V_6x_6}{M_6} \quad (46)$$

$$\frac{dx_7}{dt} = \frac{L_f(x_f - x_7) + V_7x_7}{M_7} \quad (47)$$

The heat transfer energy balance for the last two sixth and seventh effects are

$$V_5\lambda_5 = U_6A_6(T_5 - T_6) \quad (48)$$

$$(1-m)V_6\lambda_6 = U_7A_7(T_6 - T_7) \quad (49)$$

The final energy balance equation after using the correlations of the latent heat of vaporization (λ), enthalpy of vapor (H) and enthalpy of black liquor (h_L), for the last two effects sixth and seventh effects are as presented in Equations (50)-(51).

$$\frac{dT_6}{dt} = \frac{L_f[h(T_7, x_7) - h(T_6, x_6)] + U_6 A_6 (T_6 - T_7) - V_6 [H(T_6) - h(T_6, x_6)] + 2.26098 T_6 [L_7 (x_7 - x_6) + V_6 x_6]}{M_6 (4.187 - 2.26098 x_6)} \quad (50)$$

$$\frac{dT_7}{dt} = \frac{L_f [h_f - h(T_7, x_7)] + (1 - m) V_6 \lambda_6 - V_7 [H(T_7) - h(T_7, x_7)] + 2.26098 T_7 [L_f (x_f - x_7) + V_7 x_7]}{M_7 (4.187 - 2.26098 x_7)} \quad (51)$$

Dynamics of backward feed flow with feed and steam split operation (Model-E)

This Model-E is incorporated with the features of Model-B and Model-C in which both the operation steam split as well as liquor feed split arrangements has been associated. Therefore, the dynamics of Model-D is modified at first three and last two effects due to steam split and liquor feed split operation.

The total mass balances for the first two effects are the same as Model-B and sixth and seventh effects are as follows similar to Model-C

$$\frac{dM_6}{dt} = L_7 + (1 - k)L_f - L_6 - V_6 \quad (52)$$

$$\frac{dM_7}{dt} = kL_f + L_7 - V_7 \quad (53)$$

Due to the steam split operation in which the fresh steam flow rate to the first and second effects of HEE system is obtained through the energy balance as given in Equation (54) and remains the same for first two effects as in Model-C.

$$yS\lambda_0 = U_1 A_1 (T_s - T_1) \text{ and } (1 - y)S\lambda_0 = U_2 A_2 (T_s - T_2) \text{ respectively} \quad (54)$$

For the third effect heat transfer rate is given by Equation (55),

$$(V_1 + V_2)(\lambda_{T1} + \lambda_{T2}) = U_3 A_3 (T_2 - T_3) \quad (55)$$

Now, the energy balance equation for the first to third effects after using the above correlations of the latent heat of vaporization (λ), enthalpy of vapor (H) and enthalpy of black liquor (h_L), the energy balance equations after simplification for the first to third effects are written by Equations (56) - (58).

$$\frac{dT_1}{dt} = \frac{L_2 [h(T_2, x_2) - h(T_1, x_p)] + y U_1 A_1 (T_s - T_1) - V_1 [H(T_1) - h(T_1, x_p)]}{M_1 (4.187 - 2.26098 x_p)} \quad (56)$$

$$\frac{dT_2}{dt} = \frac{L_3 [h(T_3, x_3) - h(T_2, x_2)] + (1 - y) U_2 A_2 (T_s - T_2) - V_2 [H(T_2) - h(T_2, x_2)] + 2.26098 T_2 [L_3 (x_3 - x_2) + V_2 x_2]}{M_2 (4.187 - 2.26098 x_2)} \quad (57)$$

$$\frac{dT_3}{dt} = \frac{L_4 [h(T_4, x_4) - h(T_3, x_3)] + U_3 A_3 \left(\frac{T_{V1} + T_{V2}}{2} - T_3 \right) - V_3 [H(T_3) - h(T_3, x_3)] + 2.26098 T_3 [L_4 (x_4 - x_3) + V_3 x_3]}{M_3 (4.187 - 2.26098 x_3)} \quad (58)$$

The energy balance equations after the simplification for the sixth and seventh effects are written by Equations (59) - (60) and for the fourth and fifth effects remain similar as in the Model-A.

$$\frac{dT_6}{dt} = \frac{L_f [h(T_7, x_7) - h(T_6, x_6)] + (1 - k)L_f [h_f - h(T_6, x_6)] + U_6 A_6 (T_6 - T_7) - V_6 [H(T_6) - h(T_6, x_6)] + 2.26098 T_6 [(1 - k)L_f (x_f - x_6) + L_7 (x_7 - x_6) + V_6 x_6]}{M_6 (4.187 - 2.26098 x_6)} \quad (59)$$

$$\frac{dT_7}{dt} = \frac{kL_f[h_f - h(T_7, x_7)] + U_7 A_7 (T_7 - T_f) - V_7 [H(T_7) - h(T_7, x_7)] + 2.26098 T_7 [kL_f (x_f - x_7) + V_7 x_7]}{M_7 (4.187 - 2.26098 x_7)} \quad (60)$$

Dynamics of backward feed flow with steam split and feed preheating operation (Model-F)

The Model-F is incorporated by coupling the basic backward feed flow model (Model-A) with the steam split and preheating arrangements. Therefore, the dynamics of the model is modified for the first three effects due to steam split (as in Model-B) and the last two effects due to preheating (as in the Model-D).

Due to the steam split operation in which the fresh steam flow rate to the first and second effects of HEE system is obtained through the energy balance as given in Equation (61).

$$yS\lambda_0 = U_1 A_1 (T_s - T_1) \text{ and } (1-y)S\lambda_0 = U_2 A_2 (T_s - T_2) \text{ respectively} \quad (61)$$

For the third effect, the heat transfer rate is given by Equation (62)-

$$(V_1 + V_2)(\lambda_{T1} + \lambda_{T2}) = U_3 A_3 (T_2 - T_3) \quad (62)$$

The heat transfer energy balance for the sixth and seventh effects are

$$V_5 \lambda_5 = U_6 A_6 (T_5 - T_6) \quad (63)$$

$$(1-m)V_6 \lambda_6 = U_7 A_7 (T_6 - T_7) \quad (64)$$

The energy balance equation for the first to third effects are presented in Equations (65) - (67).

$$\frac{dh(T_1, x_p)}{dt} = \frac{L_2 [h(T_2, x_2) - h(T_1, x_p)] + yU_1 A_1 (T_s - T_1) - V_1 [H(T_1) - h(T_1, x_p)]}{M_1} \quad (65)$$

$$\frac{dh(T_2, x_2)}{dt} = \frac{L_3 [h(T_3, x_3) - h(T_2, x_2)] + (1-y)U_2 A_2 (T_s - T_2) - V_2 [H(T_2) - h(T_2, x_2)]}{M_2} \quad (66)$$

$$\frac{dh(T_3, x_3)}{dt} = \frac{L_4 [h(T_4, x_4) - h(T_3, x_3)] + U_3 A_3 \left(\frac{T_{V1} - T_{V2}}{2} - T_3 \right) - V_3 [H(T_3) - h(T_3, x_3)]}{M_3} \quad (67)$$

After the rearrangements, simplification and using the correlations of the latent heat of vaporization (λ), enthalpy of vapor (H) and enthalpy of black liquor (h_L), the energy balance equations are as follows. For the first three effects, last two sixth and seventh effects are presented in Equations (68) - (70) and Equations (71) - (72) respectively.

$$\frac{dT_1}{dt} = \frac{L_2 [h(T_2, x_2) - h(T_1, x_p)] + yU_1 A_1 (T_s - T_1) - V_1 [H(T_1) - h(T_1, x_p)]}{M_1 (4.187 - 2.26098 x_p)} \quad (68)$$

$$\frac{dT_2}{dt} = \frac{L_3 [h(T_3, x_3) - h(T_2, x_2)] + (1-y)U_2 A_2 (T_s - T_2) - V_2 [H(T_2) - h(T_2, x_2)] + 2.26098 T_2 [L_3 (x_3 - x_2) + V_2 x_2]}{M_2 (4.187 - 2.26098 x_2)} \quad (69)$$

$$\frac{dT_3}{dt} = \frac{L_4 [h(T_4, x_4) - h(T_3, x_3)] + U_3 A_3 \left(\frac{T_{V1} + T_{V2}}{2} - T_3 \right) - V_3 [H(T_3) - h(T_3, x_3)] + 2.26098 T_3 [L_4 (x_4 - x_3) + V_3 x_3]}{M_3 (4.187 - 2.26098 x_3)} \quad (70)$$

$$\frac{dT_6}{dt} = \frac{L_7 [h(T_7, x_7) - h(T_6, x_6)] + U_6 A_6 (T_6 - T_7) - V_6 [H(T_6) - h(T_6, x_6)] + 2.26098 T_6 [L_7 (x_7 - x_6) + V_6 x_6]}{M_6 (4.187 - 2.26098 x_6)} \quad (71)$$

$$\frac{dT_7}{dt} = \frac{L_f [h_f - h(T_7, x_7)] + (1-m)V_6 \lambda_6 - V_7 [H(T_7) - h(T_7, x_7)] + 2.26098 T_7 [L_f (x_f - x_7) + V_7 x_7]}{M_7 (4.187 - 2.26098 x_7)} \quad (72)$$

Dynamics of backward feed flow with steam and feed split and feed preheating operation (Model-G)

Finally, Model-G combines all the operations mentioned earlier: a steam split operation as in Model-B with split fraction, y and $(1-y)$, a feed split operation as in Model-C with split fractions, k and $(1-k)$, and feed preheating operation (using preheaters, PH-1 and PH-2) as in Model-D. Therefore, the equations derived for the model would assume added features of these mentioned process strategies, and hence, the dynamic equations are self-explanatory.

3. SUMMARY

The previous research studies that have catered to developing steady-state models for multiple-effect evaporators have been extended here by developing models for the *transient* analysis for the different process configurations based on backward feed flow. This work attempts to solve the basic component and energy balance equations for a heptads' effect evaporator system, and thereby, propose for the first time the dynamic model, equations and behavior of different possible process configurations. The proposed models shall help to find the dynamic behavior and transient numerical solution that shall serve to effectively control the process parameters, namely liquor level, evaporator temperatures and pressures, etc. Further, knowing the dynamic behavior of the process shall help to optimize the process based on energy requirements more accurately.

4. ACKNOWLEDGEMENTS

The authors would like to thank Director of Star paper Mill, Saharanpur, India for permissions to visit the mill to collect the real-time plant data. The authors would like to acknowledge Prof. A. K. Ray (Department of Polymer and Process Engineering) and Dr. Millie Pant (Department of Applied Science and Engineering) from IIT Roorkee for some of their useful discussions and suggestions related to the problem solution.

References

- [1] M. Morandin, A. Toffolo, A. Lazzaretto, F. Maréchal, A. V. Ensinas, and S.A. Nebra, "Synthesis and parameter optimization of a combined sugar and ethanol production process integrated with a CHP system," *Energy*. Vol 36(6). pp. 3675-3690, 2011.
- [2] N. J. Rao, and R. Kumar, "Energy conservation approaches in a paper mill with special reference to the evaporator plant," In Proc. IPPTA Int. Seminar on Energy Conservation in Pulp and Paper Industry. pp. 58-70, 1985.
- [3] D. Q. Kern, *Process heat transfer*. Tata McGraw-Hill Education. 1950.
- [4] C. D. Holland, *Fundamentals and Modelling of Separation Processes*. Englewood cliffs, New Jersey: Prentice Hall Inc. 1975.
- [5] H. Nishitani, and E. Kunugita, "The optimal flow-pattern of multiple effect evaporator systems," *Computers & Chemical Engineering*. Vol 3(1). pp. 261-268, 1979.
- [6] W. O. Ayangbile, E.O. Okeke, and G.S.G. Beveridge, "Generalised steady-state cascade simulation algorithm in multiple-effect evaporation," *Computers & Chemical Engineering*. Vol 8(3). pp. 235-242, 1984.
- [7] N. H. Aly, and M. A. Marwan, "Dynamic response of multi-effect evaporators," *Desalination*. Vol 114(2). pp. 189-196, 1997.
- [8] V. Miranda and R. Simpson, "Modelling and simulation of an industrial multiple effect evaporator: tomato concentrate," *Journal of Food Engineering*. Vol 66(2). pp. 203-210, 2005.
- [9] G. Jyoti, and S. Khanam, "Simulation of heat integrated multiple effect evaporator system," *International Journal of Thermal Sciences*. Vol 76. pp. 110-117, 2014.
- [10] Q. Ruan, H. Jiang, M. Nian, and Z. Yan, "Mathematical modeling and simulation of countercurrent multiple effect evaporation for fruit juice concentration," *Journal of Food Engineering*. Vol 146. pp. 243-251, 2015.

- [11] O. P. Verma, T. H. Mohammed, S. Mangal, and G. Manik, "Mathematical Modeling of Multistage Evaporator System in Kraft Recovery Process," In Proceedings of Fifth International Conference on Soft Computing for Problem Solving, Springer Singapore, pp. 1011-1042, 2016.
- [12] R. N. Lambert, D. D. Joye, and F. W. Koko, "Design calculations for multiple-effect evaporators. 1. Linear method," *Industrial & Engineering Chemistry Research*. Vol 26(1). pp. 100-104, 1987.
- [13] O. S. Zain, and S. Kumar, "Simulation of a Multiple Effect Evaporator for Concentrating Caustic Soda Solution-Computational Aspects," *Journal of Chemical Engineering of Japan*. Vol 29(5). pp. 889-893, 1996.
- [14] R. Bhargava, S. Khanam, B. Mohanty, and A. K. Ray, "Simulation of flat falling film evaporator system for concentration of black liquor," *Computers & Chemical Engineering*. Vol 32(12). pp. 3213-3223, 2008.
- [15] S. Khanam, and B. Mohanty, "Energy reduction schemes for multiple effect evaporator systems," *Applied Energy*. Vol 87(4). pp. 1102-1111, 2010.
- [16] G. Gautami, and S. Khanam, "Selection of optimum configuration for multiple effect evaporator system," *Desalination*. Vol 288. pp. 16-23, 2012.
- [17] D. Srivastava, B. Mohanty, and R. Bhargava, "Modeling and simulation of MEE system used in the sugar industry," *Chemical Engineering Communications*. Vol 200(8). pp. 1089-1101, 2013.
- [18] D. Kumar, V. Kumar, and V. P. Singh, "To study the parametric effects on optimality of various feeding sequences of a multi-effect evaporators in paper industry using mathematical modeling and simulation with MATLAB," *International Journal of Chemical and Biological Engineering*. Vol 3(3). pp. 129-136, 2010.
- [19] M. Danish, and S. P. Singh, "A short note on the solution of a multi-effect evaporator system employed in pulp and paper industry," *Applied Mathematical Modelling*. Vol 38(15). pp. 4157-4160, 2014.
- [20] S. Y. Wu, S. M. Zhou, L. Xiao, Y. R. Li, C. Liu, and J. L. Xu, "Determining the optimal pinch point temperature difference of evaporator for waste heat recovery," *Journal of the Energy Institute*. Vol 87(2). pp. 140-151, 2014.
- [21] M. Sagharichiha, A. Jafarian, M. Asgari, and R. Kouhikamali, "Simulation of a forward feed multiple effect desalination plant with vertical tube evaporators," *Chemical Engineering and Processing: Process Intensification*. Vol 75. pp. 110-118, 2014.
- [22] J. W. Burdett and C. D. Hollanu, "Dynamics of a multiple-effect evaporator system," *AIChE Journal*. Vol 17(5). pp. 1080-1089, 1971.
- [23] S. M. Tonelli, J. Romagnoli, and J. Porras, "Computer package for transient analysis of industrial multiple-effect evaporators," *Journal of Food Engineering*. Vol 12(4). pp. 267-281, 1990.
- [24] C. H. Runyon, T. R. Rumsey, and K. L. Mccarthy, "Dynamic simulation of a nonlinear model of a double effect evaporator," *Journal of Food Engineering*. Vol 14(3). pp. 185-201, 1991.
- [25] M. P. C. M. Van Wijck, P. Quaak, And J. J. Van Haren, "Multivariable supervisory control of a four-effect falling-film evaporator," *Food control*. Vol 5(2). 83-89, 1994.
- [26] D. Kumar, V. Kumar, and V. P. Singh, "Modeling and dynamic simulation of mixed feed multi-effect evaporators in paper industry," *Applied Mathematical Modelling*. Vol 37(1). pp. 384-397, 2013.
- [27] A. M. El-Nashar, and A. Qamhiyeh, "Simulation of the performance of MES evaporators under unsteady state operating conditions," *Desalination*. Vol 79(1). pp. 65-83, 1990.
- [28] Y. Izawa, and K. Hakomori, "Nonlinear Control of a Double-Effect Evaporator by Riemannian Geometric Approach," *Automatic Measurement Proceedings of the Royal Society*. Vol 32(2). pp. 197-206, 1996.
- [29] L. C. To, M. O. Tadé, and G. P. Le Page, "Implementation of a differential geometric nonlinear controller on an industrial evaporator system," *Control Engineering Practice*. Vol 6(11). pp. 1309-1319, 1998.
- [30] G. P. Rangaiah, P. Saha, and M. O. Tadé, "Nonlinear model predictive control of an industrial four-stage evaporator system via simulation," *Chemical Engineering Journal*. Vol 87(3). pp. 285-299, 2002.
- [31] M. Karimi and A. Jahanmiri, "Nonlinear modeling and cascade control design for multi-effect falling film evaporator," *Iran. J. Chem. Eng.* Vol 3(2). pp. 52-63, 2006.
- [32] D. Kaya, and H. I. Sarac, "Mathematical modeling of multiple-effect evaporators and energy economy," *Energy*. Vol 32(8). pp. 1536-1542, 2007.
- [33] P. Yadav, and A. K. Jana, "Simulation and Control of a Commercial Double Effect Evaporator: Tomato Juice," *Chemical Product and Process Modeling*. Vol 5(1). 2010.