

Comparative Structural Analyses of Groundnut RGAs for Development of STS Markers

Siddanna Savadi^{1,2,3*}, Nemappa Lambani², V. Hanumanth Nayak², Vinodkumar S. B.² and B. Fakrudin³, H. L. Nadaf³

Abstract: Analyses of groundnut RGA database was done to select 21 RGAs out 450 RGAs which showed homology with Flax rust resistance protein during Blast search. Multiple sequence alignments were performed on the 21 RGA sequences and a cluster analysis was performed to generate a phylogenetic tree. The groundnut RGA nucleotide sequences were arranged into 6 groups based on genetic distances. One or two RGA sequences from the six groups were used to design eight RGA-sequence-tagged site primers. Out of these eight primers 5 amplified with groundnut genomic DNA. Using these RGA-specific primers screening for polymorphism between eight resistant and eight susceptible cultivars for rust and late leafspot diseases of groundnut was carried out. None of these RGA-STs primers could detect polymorphism between them and even restriction analysis of PCR products of all the amplified primers across all genotypes did not show any polymorphism. These results indicate that RGAs may be more conserved with little variations at nucleotide levels and also there is need of large number of suitable RGA resource to detect polymorphism in crop like groundnut where little polymorphism is reported because of its complex genome.

Keywords: Resistance, RGA, Arachis, Marker, STS

INTRODUCTION

Groundnut (*Arachis hypogaea* L.) is an important oilseed crop and a prominent because of its economically important commodity. It is grown in six continents as an important oilseed crop in approximately 32 m ha in over 100 countries (larna.anthro.uga.edu). It is the third major oilseed crop in the world next only to soybean and cotton. *A. hypogaea* is believed to have originated in the Southern Bolivia to Northern Argentina region of South America. The present day groundnut is an allotetraploid ($2n=4x=40$) while most of wild relatives are diploid ($2n=2x=20$).

Prevalence of frequent abiotic and consistent pressure of pests and diseases have limited groundnut yield less than 900 kg per ha in most of the semiarid situations. Foliar diseases especially rust caused by *Puccinia arachidis* [Speg.] and late leaf spot caused by *Cercospora arachidicola* [Hori] of groundnut and cause toll of 50% losses in susceptible varieties. The chemical

control measures are not economical besides their ill effects on environment. Digenic rust resistance inheritance has been reported by Bromfield and Bailey (1972), Nigam *et al.* (1980) and Vindhiyavarman *et al.* (1993). Partial dominance was the possible cause for the highly resistant F1's obtained from interspecific crosses, where the almost immune wild species was the donor for rust resistance (Singh *et al.* 1984). Identification of resistant genotypes needs careful, repeated and thorough screening under ideal epiphytotic conditions, which is time consuming and laborious. Molecular markers associated with rust resistance would hasten the process of identification of resistant genotypes. Molecular marker for a disease resistance gene is determined by (i) how close the marker is linked to the gene, (ii) how easy the marker can be identified, and (iii) more importantly, whether the marker is polymorphic. The resistance gene analog polymorphism (RGAP) tech-nique (Chen *et al.* 1998), which utilizes high-resolution electrophoresis and

¹ Indian Institute of Wheat and Barley, Karnal-132002

² Indian Agricultural Research Institute, New Delhi-110012

³ University of Agricultural Sciences, Dharwad-58001

*Corresponding author E-mail: siddannasavadi@gmail.com

sensitive detection of polymerase chain reaction (PCR) products amplified with primers based on conserved domains of plant resistance genes, has been used to identify molecular markers tightly linked to or cosegregating with disease resistance genes (Toojinda *et al.* 2000; Shi *et al.* 2001; Yan *et al.* 2003).

Plant R genes are characterized by several key features including nucleotide-binding site (NBS) domains, leucine-rich repeat (LRR) regions, transmembrane (TM) regions, and serine/threonine kinase catalytic domains (Martin *et al.* 2003). Plant resistance gene analogues (RGAs) have been isolated from numerous plant species, using degenerate primers designed from well-characterized R-gene products, predominantly from NBS and LRR regions (Leister *et al.* 1996; Chen *et al.* 1998; Madsen *et al.* 2003). The use of degenerate R-gene primers has proven very effective in identifying R genes from very diverse species of plants. RGAs have been used as markers to tag disease resistance genes in plants (Yan *et al.* 2003; Huang *et al.* 2004). STS and SSR markers are simple, rapid and inexpensive, thus are suitable for screening of breeding materials in MAS programs. The breeding and selection of *Theobroma cacao* has recently been benefited from the identification of RGA DNA markers designed from the NBS and LRR domains of known resistance genes (Kuhn *et al.* 2003) and the DNA-binding domain and other conserved motifs of the WRKY family of plant transcriptional regulators (Borrone *et al.* 2004). Recent advances in sequencing technology allow large-scale use for many fragments and many individuals (Meyer *et al.* 1999) and are improved with respect to cost and accuracy (Marziali and Akeson, 2001). In NCBI GENBANK a large number RGA sequences have been deposited, which will be of great use for development RGA makers at lesser expenses. STS markers are single-copy DNA sequences of known map location could serve as markers.

Cultivated groundnut exhibits a considerable amount of variability for various morphological, physiological and agronomic traits. However, a low level of variation has been detected at DNA level using RAPD (Halward *et al.* 1991, 1992; Subramanian *et al.* 2000), ISSR (Raina *et al.* 2001), AFLP (Herselman 2003) and SSR (He *et al.* 2003) markers. With limited sequence information in groundnut, few economically important traits have been tagged using molecular markers, namely, nematode resistance using RAPD (Burrow *et al.* 1996; Garcia *et al.* 1996), resistance to the aphid vector causing groundnut rosette disease

using AFLP (Herselman *et al.* 2004), and resistance to seed infection by *Aspergillus xavus* using AFLP analysis (Yong *et al.* 2005). In this study we attempt to explore the available RGA sequences for their homology loci with well known rust R genes from wheat and flax.

MATERIALS AND METHODS

RGA sequences

Groundnut RGA sequences available in NCBI GenBank database were downloaded through ftp and also searched for reported rust genes in dicot species such as soybean, flax and other pulses. Using BLAST tool groundnut RGAs having homology with reported rust *R-genes* from dicot species identified and explored as RGA-STS markers. RGA nucleotide sequences were aligned using the program Align X (component of vector NTI, Invitrogen Inc., USA, 2006), with default cost settings for opening and extending gaps. The neighbor-joining method was used to generate a phylogenetic tree of the RGA nucleotide sequences. The RGA sequences were then analyzed by multiple sequence alignment using Align X and were divided into groups according to genetic relatedness. The PCR primers were designed for one or two individual nucleotide sequence within each of the group. Using FastPCR (Kalendar, 2004) software.

DNA preparation

Total DNA was isolated from a set of 8 resistant and 8 susceptible breeding lines/ cultivars of groundnut following CTAB protocol of Murry and Thompson (1980), with suitable modifications. The genomic DNA after RNase treatment was used as the template for all PCR amplifications. Varieties with a 1-3 disease score LSVT-2003-1, ISK-I-20004-4, IVT-I-2005-5, GPBD-4, ASK-2005-1, OCG-17, DRT-2004-10 and LSVT-2005-4 were designated as resistant and a 4-9 score JL-24, TMV-2, Dh-40, TAG-24, ICGV-9112-1 15-T, TG-26 and TPG-41 as susceptible according to Pande and Rao (2001).

PCR amplification

The functionality of the RGA-STS primers was determined by PCR amplification using genomic DNA. Working primer sets were screened for RGA-STS polymorphisms in a set of resistant and susceptible genotypes.

For PCR amplification, 20 µl reaction mixtures containing 10 mM Tris-HCl (pH 8.8), 50 mM KCl, 10

mM MgCl₂, 2.5 mM of each of dNTPs, 20pM each of forward and reverse primers, 50 ng of genomic DNA and 2.5U *Taq* DNA polymerase (MBI Fermentas). Amplification conditions were; initial denaturation at 94 °C for 4 min, followed by 30 cycles of 94 °C for 1 min, 50-56 °C (depending on the primer combination) for 1 min and 72 °C for 1 min and a final extension of 72 °C for 20 min using a Master Cycler gradient 5331 (Eppendorf). The annealing temperature optimum for each primer combination was determined by the gradient function of thermal cycler before actual PCR reaction for elution of the specific amplicon was performed. The PCR products in 10 µl were resolved in 1.2% agarose (Sigma-Aldrich, USA) gel using 1× TBE (89mM Tris-HCl, 89 mM boric acid and 2mM EDTA pH 8.0) buffer stained with ethidium bromide (0.75 µg/ml) and visualized under UV transilluminator (UVI Tech, England) and results were documented. The size of the amplified fragments was estimated by comparison with a 100-bp ladder (Bangalore Genei Pvt. Ltd., Bangalore, India). Restriction of PCR products amplified by RGA-STs markers was carried out using four base cutters (*BsuRI* and *TaqI*) under optimized restriction conditions to look for restriction site differences. For restriction 30 µl reaction mixture containing 17 µl Nuclease free H₂O, 2 µl 10X assay (10mM Tris HCl, 100mM KCl, 1mM EDTA, 1mM DTT, 0.2mg/ml BSA and 50% glycerol, pH 7.4) Buffer, 10 µl PCR products and 1 µl Enzyme from Fermentas were used.

RESULTS

DNA markers linked to traits of economic important help in breeding programme. Identification of DNA markers linked to rust disease in groundnut is important for development of resistance cultivars. In this study a bioinformatic approach was used to find RGA-markers using RGA database and then their functionality and ability to detect polymorphism was tested in 8 resistant and 8 susceptible species. Out of 450 groundnut RGA sequences downloaded from database 21 RGA sequences were chosen based on their homology with flax (*Linum usitatissimum*) rust R-genes; GIs are listed in Table 1. These selected sequences were aligned (Fig. 1) and the cluster analysis of these RGA sequences resulted in 6 groups (Fig. 2), which clearly indicated groupings according to sequence similarity. It is important to note that the dendrogram representation of the cluster analysis that have different branch lengths are representative of the genetic distance among the RGA nucleotide sequences. Overall, distinct six groups of RGAs

could be identified among those that shared significant homology with flax RGAs. Eight primers were designed using one or two sequences from six groups and they were called as RGA-STs primers (Table 2).

Five out of eight RGA-STs primer pairs amplified a prominent DNA fragment of predicted size (Table 2) as visualized on 2% agarose gel. However, in two instances, other DNA fragments of varying sizes were also evident as faint, minor and prominent, major PCR products (Plate 1). Groundnut genomic DNA from the eight resistant and eight susceptible (for rust and late leafspot) genotypes was amplified for polymorphic DNA markers, using the RGA-STs primers. Of the five RGA-STs primer pairs used in the PCR reactions, none amplified DNA fragments of those were polymorphic among groundnut genotypes used (Plate 2). Even restriction digestion of PCR products with four base restriction enzymes, *TaqI* and *BsuRI*, did not result in any polymorphism with respect to restriction enzymes sites (Plate 3). These results indicate that the RGA sequences are less variable parts of plant genome and indicated the need to go further deeper at nucleotide by nucleotide comparison between resistant and susceptible cultivars.

DISCUSSION

Considerable efforts have been made to identify sources of resistance to rust in groundnut because of its importance worldwide. RGAs have been used to identify candidates for resistance genes in several plant species, and are believed to be significantly associated with QTLs conferring resistance to pests (Wisser *et al.* 2005). While the development of molecular markers has shifted from anonymous DNA fragments to Gene-based PCR markers, also called functional markers. Utilizing RGA sequences deposited in genbank for development of RGA markers is a proven method. The breeding and selection of *Theobroma cacao* has recently been benefited from the identification of RGA DNA markers designed from the NBS and LRR domains of known resistance genes (Kuhn *et al.* 2003) and the DNA-binding domain and other conserved motifs of the WRKY family of plant transcriptional regulators (Borrone *et al.* 2004).

Conventional groundnut breeding selections rely mainly on bioassays such as severity of disease symptoms and on the ability of the breeder to identify desirable traits for generation advancement. These techniques can be extremely subjective and

bioassays can lead to false selections due to environmental factors such as non-uniform distribution of pathogens in the field. Clearly, identification of R-gene-linked DNA markers and/or genes that confer natural resistance to pests/diseases would be greatly beneficial to the in terms of overhead expenditures. But the development of these RGA DNA markers until recently was too expensive, laborious and inaccurate for routine use. Recent advances in sequencing technology allow large-scale use for many fragments and many individuals (Meyer *et al.* 1999) and are improved with respect to cost and accuracy (Marziali and Akeson, 2001).

In this study, one of major concerns was to develop RGA-STS markers derived from the RGA-STS primer pairs (Table 2) designed from the cluster analysis of peanut RGA resources (Fig. 2). There was clear representation of the RGA groups assigned to the groundnut RGAs using a dendrogram based on genetic distance among the 21 groundnut RGAs. Primers were designed for eight and only five of them amplified. The groundnut RGA-STS primer pairs designed from the individual sequences of RGAs of different groups, were developed to amplify a major DNA fragment of specific size. However, in two cases of RGA-STS (AhRGA7627, AhRGA1206) primer multiple bands were evident as major and minor amplification products for each pair of RGA-STS primers. In all cases, the major amplification products of predicted sizes were present when PCR products were resolved on a 2% agarose gel. Since the RGA-STS primers are highly specific, it is presumed that the other bands are also groundnut RGA sequences representing an R-gene family containing the similar motifs. This presumption conforms to observations that many R-gene families cluster in plant genomes to loci associated with resistance to a specific pathogen or pathogens (Leister, 2004). Variations in the size of genes may also be due to duplicated R-genes which could also lead to multiple PCR products of varying sizes as demonstrated in Plate 1.

Utilizing RGA sequences deposited in genbank for development of RGA markers is a proven method in several plant species, for example Hinchliffe *et al.* (2005) developed nine polymorphic RGA-STS markers in cotton using 99 cotton RGA nucleotide sequences already deposited in GenBank and 57 of RGA nucleotide sequences isolated and revealed by them.

Out of five RGA-STS primers used in the present study none amplified polymorphic amplicons and

restriction of PCR products of RGA-STS primers with frequent cutters (*BSuRI* and *TaqI* restriction enzymes) which may be because RGA sequences are less variable parts of plant genome and variations in many of these sequences differ only slightly by substitutions, deletions, and/or insertions at the nucleotide level or SNP level (SNPs are the most abundant in the genome) as found in alignment of groundnut RGA sequences. Another reason for this is lack sufficient RGA resource having motif conservation with reported rust R-genes to design large number of RGA-STS primers needed to detect polymorphism in crop like groundnut where limited variations are detected because of complex nature of its genome i.e. small chromosome size, multiallelic loci, the presence of much repetitive and redundant DNA and also functional sequences being confined to a small region (Singh *et al.* 1998).

Table 1
Groundnut RGAs showing similarity to gene putatively involved in rust resistance in flax (*Linum usitatissimum*) species; with their accession ID, No in dendrogram, e-values in blast search and RGA groups based on multiple alignment

Sl No	Accession ID	No in dendrogram	e-value	RGA group
1	gi 62177627*	11	7.00E-98	RG I
2	gi 62177533	12	3.00E-95	RG I
3	gi 62177615	15	1.00E-92	RG II
4	gi 62177563*	16	2.00E-91	RG II
5	gi 62177545*	20	9.00E-91	RG II
6	gi 62361180	18	3.00E-90	RG III
7	gi 62361220	19	4.00E-89	RG III
8	gi 62361206*	22	3.00E-87	RG III
9	gi 62361294	23	2.00E-85	RG III
10	gi 62361200*	25	4.00E-79	RG III
11	gi 62361158	26	6.00E-79	RG IV
12	gi 62361210*	27	6.00E-79	RG IV
13	gi 62361186	28	1.00E-78	RG IV
14	gi 62361256	29	2.00E-78	RG IV
15	gi 37222014	30	2.00E-78	RG IV
16	gi 37221984	31	1.00E-77	RG IV
17	gi 62361222*	21	1.00E-77	RG V
18	gi 62361240*	24	4.00E-77	RG V
19	gi 62177625*	13	7.00E-77	RG VI
20	gi 62177573	14	2.00E-76	RG VI
21	gi 62177577	17	1.00E-92	RG VI

*RGAs selected for RGA-STS primers synthesis which were used for RGA-STS marker development

Table 2
List of RGA-STS primer pairs synthesized, with source RGA accession ID, Primer sequence information, T_m and sizes of PCR products amplified
(Non amplified primers are indicated as 'NA').

Sl. No	Primer ID	Source RGA GIDs	Forward primer sequence 5' to 3'	Reverse primer sequence 5' to 3'	T _m (°C)	Size (bp)
1	AhRGA7627	gi 62177627	5' GGGGGGATCGGGAAGAC 3'	5' TTTGCTTTGGGCCCTTGTCATTT 3'	51°C	500
2	AhRGA7625	gi 62177625	5' TGGGGGGTGGGGAAGAC 3'	5' TGCTTTGGGCCCTTGTCATTTTG 3'	NA	-
3	AhRGA1222	gi 62361222	5' GGGGGGTGGGGAACGA 3'	5' TGAGGGCGAAGGGAGTCC 3'	54°C	900, 475 & 300
4	AhRGA1206	gi 62361206	5' GGGGGGTGGGGAAGACG 3'	5' TGAGGGCGAGGGGAGTCC 3'	NA	-
5	AhRGA1240	gi 62361240	5' ATGGGATGGGTGGGGAAGAC 3'	5' TGCTTTGGGCCCTTGTCATTTTG 3'	55°C	400
6	AhRGA1200	gi 62361200	5' GGGGGGTGGGGAAGACA 3'	5' TGAGGGCGAAGGGAGAC 3'	56°C	450 & 350
7	AhRGA1210	gi 62361210	5' ACGCGAAACTTCCATATACGG 3'	5' TCCAAACAATCATCCGGTAG 3'	50°C	300
8	AhRGA1186	gi 62361186	5' GGGGGGTGGGGAAGCTAC 3'	5' AGTTGGCTCCGGATTCTGTTC 3'	NA	-

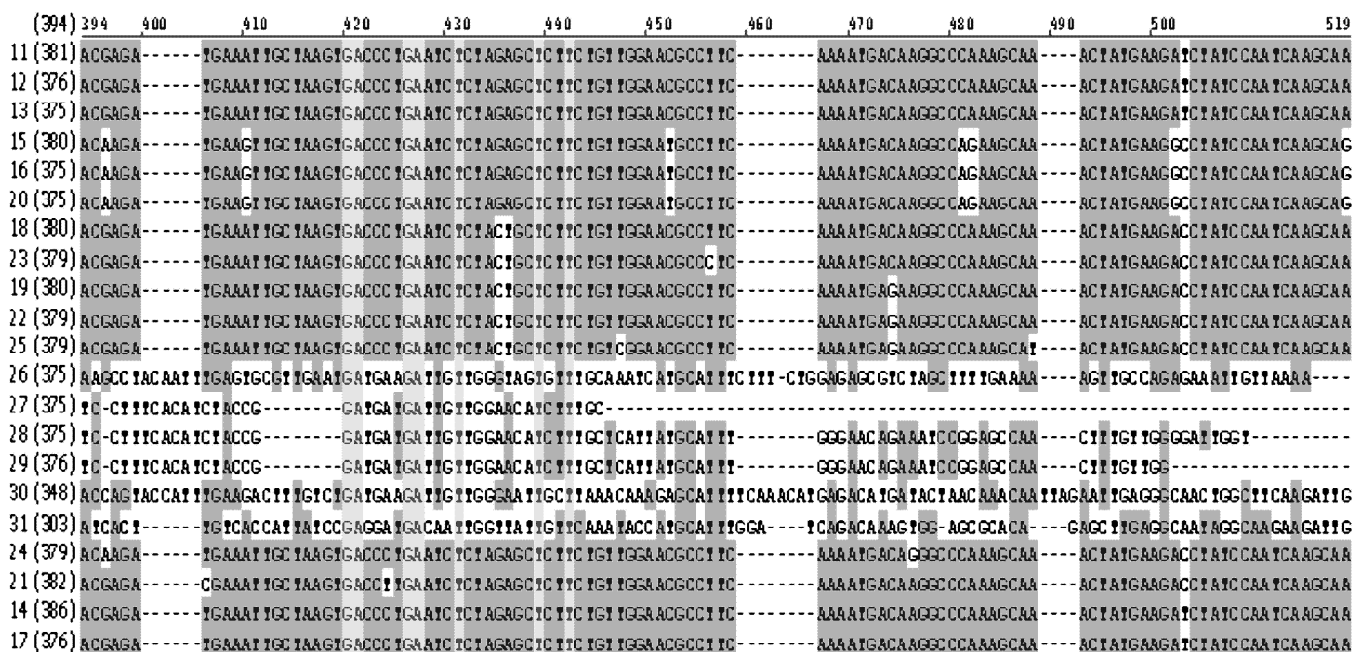

Figure 1: Multiple alignment of selected RGA sequences using Align X program and nucleotide changes in RGA sequences are shown without colour

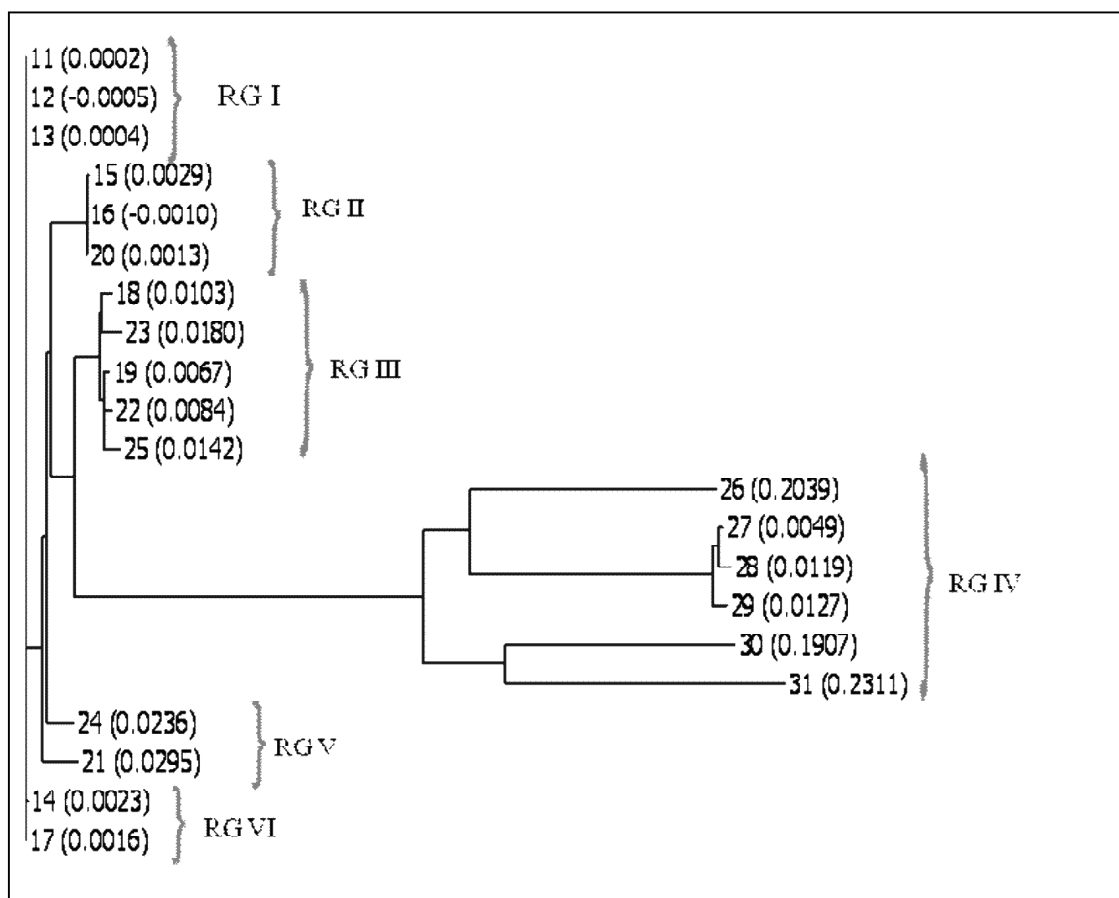

Figure 2: Dendrogram representation of a Phylogenetic tree and RGA groups (RG I-VI) formed based on multiple sequence alignment of selected RGA sequences listed in Table 2 with GenBank accession numbers

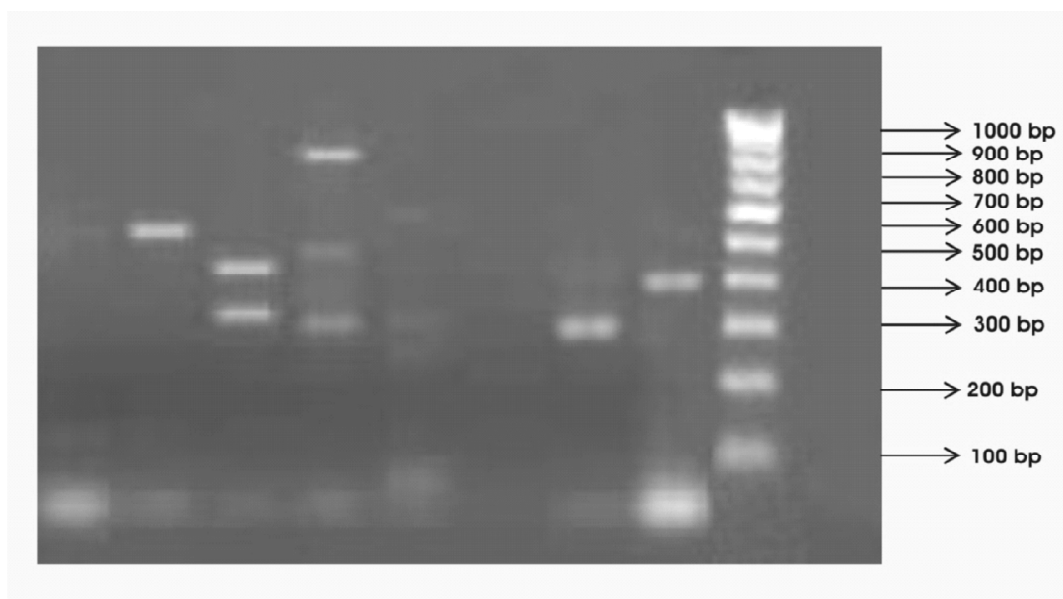

Plate 1: Amplification pattern obtained with eight RGA-STS primers screening in groundnut DNA

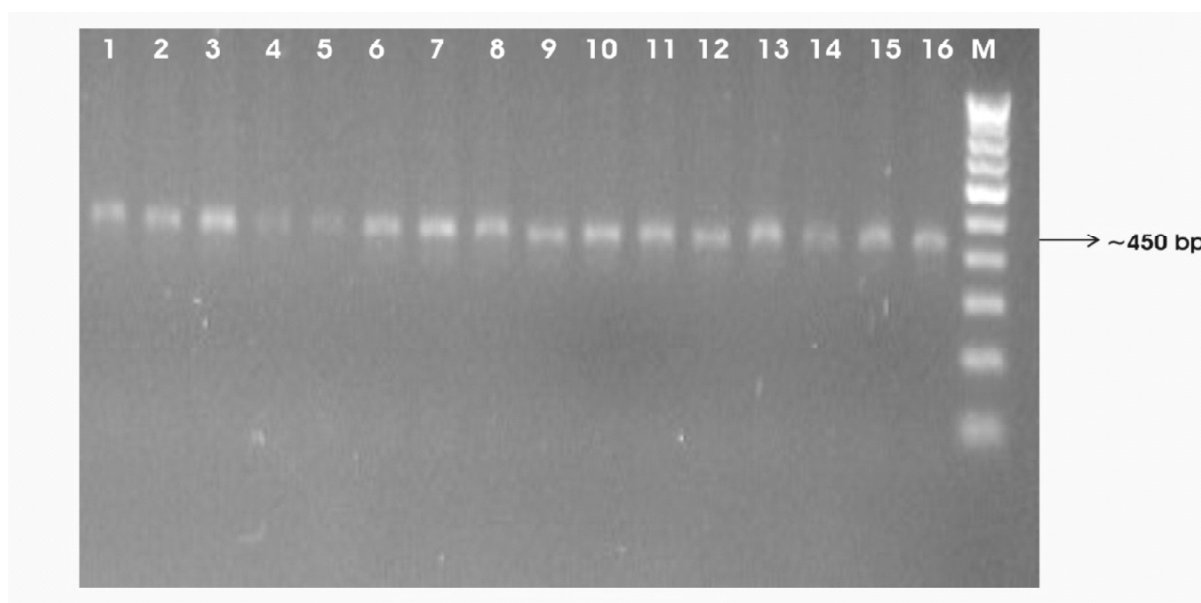

Plate 2: Amplification pattern obtained with RGA-STS primer AhRGA1240 across 16 genotypes of groundnut

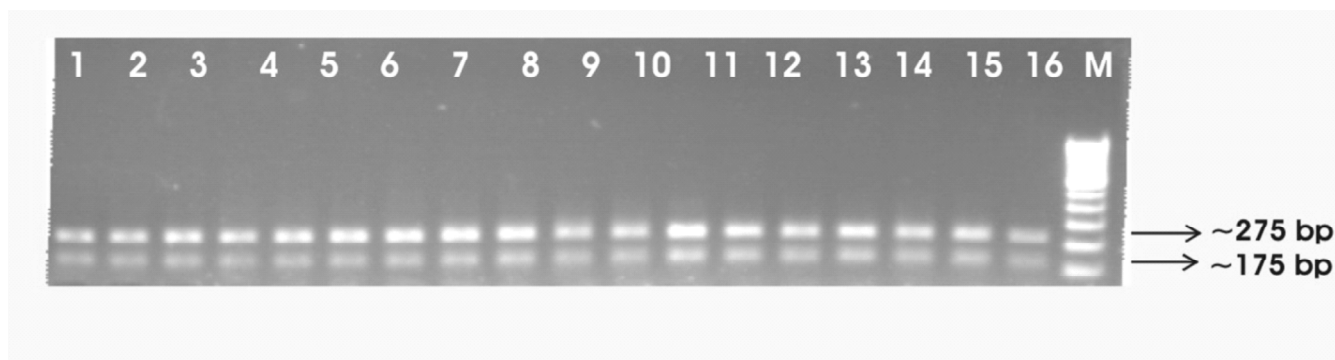

Plate 3: Restriction digestion of PCR products of RGA-STS primer AhRGA1240 with restriction enzyme *BsuRI*

REFERENCES

- Borrone, J. W.; Kuhn, D. N. and Schnell, R. J. (2004), Isolation, characterization, and development of WRKY genes as useful genetic markers in *Theobroma cacao*. *Theor Appl Genet.* 109: 495-507.
- Bromfield, K. R. and Bailey, W. K. (1972), Inheritance of resistance to *Puccinia arachidis* in peanut. *Phytopathology* 62:748.
- Burrow, M. D.; Simpson, C. E.; Paterson, A. H. and Starr, J. L. (1996), Identification of peanut (*Arachis hypogaea* L.) RAPD markers diagnostic of root-knot nematode (*Meloidogyne arenaria* (Neal) Chitwood) resistance. *Mol Breed.* 2: 368-379.
- Chen, X. M.; Line, R. F. and Leung, H. (1998), Genome scanning for resistance-gene analogs in rice, barley, and wheat by high-resolution electrophoresis. *Theor Appl Genet.* 97: 345-355.
- Garcia, G. M.; Stalker, H. T.; Shroeder, E. and Kochert, G. A. (1996), Identification of RAPD, SCAR and RFLP markers tightly linked to nematode resistance genes introgressed from *Arachis cardenasii* to *A. hypogaea*. *Genome* 39: 836-845.
- Halward, T. M.; Stalker, H. T.; Larue, E. A. and Kochert, G. (1991), Genetic variation detectable with molecular markers among unadapted germplasm resources of cultivated peanut and related wild species. *Genome* 34: 1013-1020.
- Halward, T. M.; Stalker, T.; Larue, E. A. and Kochert, G. (1992), Use of single-primer DNA amplification in genetic studies of peanut (*Arachis hypogaea* L.). *Plant Mol Biol.* 18: 315-325.
- He, G.; Meng, R.; Newman, M.; Gao, G.; Pittman, R. N. and Prakash, C. S. (2003), Microsatellites as DNA markers in cultivated peanut (*Arachis hypogaea* L.). *BMC Plant Biol.* 3:3-9.
- Herselman, L. (2003), Genetic variation among Southern African cultivated peanut (*Arachis hypogaea* L.) genotypes as revealed by AFLP analysis. *Euphytica* 133: 319-327.
- Herselman, L.; Thwaites, R.; Kimmins, F. M.; Courtois, B.; Van der Merwe, P. J. A. and Seal, S. E. (2004), Identification and mapping of AFLP markers linked to peanut (*Arachis hypogaea* L.) resistance to the aphid vector of groundnut rosette disease. *Theor Appl Genet.* 109:1426-1433.
- Hinchliffe, D. J.; Lu, Y. Z.; Potenza, C.; Segupta-Gopalan, C. and Cantrell, R. G. (2005), Resistance gene analogue markers are mapped to homologous chromosomes in cultivated tetraploid cotton. *Theor Appl Genet.* 110:1074-1085.
- Huang, D.; Wu, W. and Lu, L. (2004), Microdissection and molecular manipulation of single chromosomes in woody fruit trees with small chromosomes using pomelo (*Citrus grandis*) as a model. II. Cloning of resistance gene analogs from single chromosomes. *Theor Appl Genet.* 108: 1371-1377.
- Kalendar, R. (2004), FastPCR: PCR primer design, DNA and protein tools, repeats and own database searches program. Available via http://www.biocenter.helsinki.fi/bi/bare-1_html/fastpcr.htm
- Kuhn, D. N.; Heath, M.; Wissler, R. J.; Meerow, A.; Brown, J. S.; Lopes, U. and Schnell, R. J. (2003), Resistance gene homologues in *Theobroma cacao* as useful genetic markers. *Theor Appl Genet.* 107:191-202.
- Leister, D. (2004), Tandem and segmental gene duplication and recombination in the evolution of plant disease resistance gene. *Trends Genet.* 20:116-122.
- Leister, D.; Ballvora, A.; Salamini, F. and Gebhardt, C. 1996. A PCR-based approach for isolating pathogen resistance genes from potato with potential for wide application in plants. *Nat Genet.* 14:421-429.
- Mace, E. S.; Phong, D. T.; Upadhyaya, H. D.; Chandra, S. and Crouch, J. H. (2006), SSR analysis of cultivated groundnut (*Arachis hypogaea* L.) germplasm resistant to rust and late leaf spot diseases. *Euphytica* 152:317-330.
- Madsen, L. H.; Collins, N. C.; Rakwalska, M.; Backes, G.; Sandal, N.; Krusell, L.; Jensen, J.; Waterman, E. H.; Jahoor, A.; Ayliffe, M.; Pryor, A. J.; Langridge, P. and Schulze-lefert, P.; and Stougaard, J. (2003), Barley disease resistance gene analogs of the NBS-LRR class: identification and mapping. *Mol Genet Genomics* 269: 150-161.
- Marziali, A. and Akeson, M. (2001), New DNA Sequencing Methods. *Annual Review in Biomedical Engineering* 3: 195-223.
- Meyers, B. C.; Dickerman, A. W.; Michelmore, R.W.; Sivaramkrishnan, S.; Sobral, B.W. and Young, N. D. (1999), Plant disease resistance genes encode members of an ancient and diverse protein family within the nucleotide-binding superfamily. *Plant J.* 20:317-332.
- Nigam, S. N.; Dwivedi, S. L. and Gibbons, R. W. (1980), Groundnut Breeding at ICRISAT. In: *Proceedings international workshop on groundnut.* 13-17th Oct 1980. ICRISAT, India. 62-68.
- Pande, S. and Rao, N. J. (2001), Resistance of wild *Arachis* species to late leaf spot and rust in greenhouse trials. *Plant Disease* 85:851-855.
- Quint, M.; Mihaljevic, R.; Duple, C. M.; Xu, M. L.; Melchinger, A. E.; and Lübberstedt, T. (2002), Development of RGA-CAPS markers and genetic mapping of candidate genes for sugarcane mosaic virus resistance in maize. *Theor Appl Genet.* 105: 355-363.
- Raina, S. N.; Rani, V.; Kojima, T.; Ogihara, Y.; Singh, K. P.; and Devarumath, R. M. (2001), RAPD and ISSR Wngerprint as useful genetic markers for analysis of

- genetic diversity, varietal identification and phylogenetic relationship in peanut (*Arachis hypogaea* L.) cultivars and wild species. *Genome* 44:763-772.
- Singh, A. K.; Smartt, J.; Simpson, C. E. and Raina, S. N. (1998), Genetic variation vis-a' -vis molecular polymorphism in groundnut (*Arachis hypogaea* L). *Genet Resour Crop Evol.* 45:119-126.
- Singh, A. K.; Subrahmanyam, P. and Moss, J. P. (1984), The dominant nature of resistance to *Puccinia arachidis* in certain wild. *arachis* species. *Oleagineux.* 39:535-537.
- Subramanian, V.; Gurtu, S.; Nageswara rao, R. C. and Nigam, S. N. (2000), Identifiacion of DNA polymorphism in cultivated groundnut using random ampliWed polymorphic DNA (RAPD) assay. *Genome.* 43: 656-660.
- Vindhiyavarman, P.; Raveendran, T. S. and Ganapathi, T. (1993), Inheritance of rust resistance in groundnut. *Madras Agri J.* 80:175-176.
- Yong, L.; Boshou, L.; Wang, S. Y.; Dong, L. and Jiang, H. (2005), Identification of AFLP markers for resistance to seed infection by *Aspergillus xavus* in peanut (*Arachis hypogaea* L.). *Acta Agronomica Sinica.* 31: 1349-1353.

