

An Optimized Self Healing Reconfigurable Wireless Sensor Network Implemented on a FPGA Platform

B.R. Tapas Babu* and L.C. Siddanna Gowd**

ABSTRACT

The proposal of our research work is to develop a reconfigurable hardware to flourish an enhanced self-healing ability for sensor nodes using FPGA. Emphasizing the engineering wing, the Wireless sensor network plays a prominent role of successful applications. When there is an identification of frailty that is failing in node, it is commonly discarded and network is reorganized to ensure the normal operation of WSN. As such the maintenance cost and function of the network will decline occasionally. So we determined to design that FPGA based self-healing to develop the wireless sensor node and repair the node hardware failures. By instigating the method of self-reconfiguration and developing system using “backup module”. In this study we contemplate the encoding process to aggregate the data and FPGA based self-healing contains power killing components such as data compressor and signal transducer. We proposed to project estimation that the light weight compression and fault prediction technique in present noble time. Our method is to facilitate the researchers in diverse applications (e.g. health, military, home and engineering) areas and it also depreciate (cheapen) the maintenance cost.

Keywords: Self-healing FPGA, Wireless sensor node, Data compression, Fault recovery, Reconfiguration, Power consumption

1. INTRODUCTION

Nowadays wireless sensor networks perform one of the most outstanding and interested challenges in electronic design and telecommunication. These different networks are designed to be autonomous, low power and reconfigurable network. Wireless Sensor Networks (WSNs) are used for accumulation of data in various application settings and scenarios, such as military surveillance, environmental monitoring, medical diagnosis, building automation, industrial application tasks, fire fighting, pollution control, etc. A typical Wireless Sensor Network consists of a set of elements such that (i) Sensing Unit is used to take measurements, (ii) Computing Unit is used to process the collecting data and (iii) Communication Unit is exchanging the information among the wireless nodes. WSNs are able to sense numerous parameters with tremendous accuracy and low power consumption. The sensor nodes made up of a huge number of processing elements, sensors, a small battery and wireless transceiver which sends measurements from sensors to a gateway. In engineering areas, many sensor nodes are used extensively across geographical areas. Some of the nodes have to work in harsh atmospheres for a long term [1]. The improvement of sensors and networks based on sensor nodes is changing our everyday life.

Energy preservation is analyzed as the most critical issue in the design and operation of WSNs, due to impact on the overall lifetime of the network and efficiency. The right way to achieve energy conservation is followed by, (i) Number of required transmissions can be minimized. (ii) Optimized routing paths through the networks can be utilized. WSNs applications may include hundreds or thousands of sensor nodes. At some times, it is very crucial and able to network debugging and reprogram the nodes on a particular line,

* Research Scholar, St.Peter's University, Chennai.

** Professor, AMS College, Namakkal, Tamilnadu.

to determine the difficulties of working and performance of the WSNs. In today's world WSNs able to integrate with the physical environment in wireless domain gives more accuracy and power consumption. Currently, for the implementation of WSN involves two basic usages of nodes that single sensor nodes and multiple sensor nodes. A single sensor node can be designed by using integrating sensor unit, signal conditioner and Network Application Processor (NAP). In some times WSN maintaining cost and complexity of the network can be increased. So the multi sensor nodes are used in various parameters of a certain area to be monitored.

In this paper, we increase the lifetime of the network and to reduce the power consumption of the wireless sensor network nodes. Sometimes the network lifetime will be lost when they have worked in a nature environment for a long term. So we proposed a self healing method to recover the WSN nodes when only some parts of the node hardware have faults and this method is based on reconfigurable devices such as Field Programmable Analog Arrays (FPAA) and Field Programmable Gate Array (FPGA). But we are choosing FPGA reconfigurable hardware designs are more popular for digital sensors are capable of providing components for signal processing applications. These reconfigurable designs can optimized to maintain power consumption of wireless sensor nodes.

The structure of this paper is organized as follows: Section 2 explains the related works of our paper, section 3 described our proposed system that included light weight compression and fault prediction of self healing method. Section 4 introduces the self healing method in FPGA. Section 5 describes the experimental process of the failure nodes and self healing results. The network lifetime and power consumption of the self healing nodes also calculated and discussed in the above section. The conclusion of the paper is given in section 6.

2. RELATED WORKS

In [2, 3, 4], presents SRAM-based FPGA by identifying the configuration memory which observes the radiation changes and calculate the error rate of implemented circuit design using SEFI approach. The SEFI (Single Event Functional Interrupt) is proposed in [5-6]. The SEFI is affecting their configuration memory and thus suitable hardening techniques are needed when they are deployed in critical applications. In [7, 8] researchers have shown that the self-healing WSNs are achieved by employing self-healing services and consider disconnect the fault nodes, establish on the network self-healing and frequently abandoned energy exhaustion problem. Under some Wireless Sensor Network application such as health monitoring process, monitor the industrial process, healthcare industrial applications, home automations, etc. The wireless sensor node batteries can be replaced or recharged at a certain interval. But these nodes have to work in hard environment and supply as the long term. In [9], recommends adopting the bionic hardware to implement the reconfigurable of wireless sensor networks. These techniques based on Field Programmable Analog Array (FPAA) and adopt the key components of sink nodes then measure the spare parts in the field of wireless sensor networks. Finally, it is used to evaluate the reliability of WSN and analyze the sink nodes of reliable models. In [10], defined an analysis of effect on SEU in hardened circuits based on triple module redundancy designed and mapped on SRAM based FPGAs and works with experiments of different fault-injection in the FPGA configuration memory, then resolving the TMR architecture and noted the percentage of SEU values and report the failure rates of SEU effects.

3. PROPOSED SYSTEM

3.1. Light Weight Compression Techniques and Fault Prediction

In this paper, we proposed light weight compression techniques and fault detection techniques used to evaluate the data loss by a prediction redundant data's. WSNs are able to sensing then forwarding the sensed data and performing the function based on receiving data. Generally, certain faults occurred in sensor

nodes when a network will be disconnected the connection with the faulty circuits. These faults happen due to hardware and software glitches. But we are considering the hardware glitches and appear the faults in encoding process of the aggregated data. The internal parts of the sensor nodes include the analog and digital circuits. Reconfigurable devices have been supported in some WSN applications and this hardware design decides to solve the multi sensing problem. In analog circuits, Field programmable Analog Arrays (FPAA) and Programmable mixed signal System on Chip technology (PSoC) are two main programmable hardware technologies that are given the mixed and digital signal applications. These designs cannot be enhanced to be maintaining the accuracy and power consumption. Data conversion and Data communication process may need extra components with hardware designs which are not helpful for the implementation of the mobile WSNs or static WSNs. So we have to choose the latest technology of Field Programmable Gate Array (FPGA) based self healing which is more suitable for digital sensors. They may require additional components to the sensing operation for mixed signal applications.

3.1.1. Lightweight compression

In Wireless Sensor Network (WSN), light weight data compression method is used to monitor the environmental parameters with low resolution sensors and compression techniques can be reduce the size of the data. One of the vast challenges of large scale design with practical applicability is the improvement of the structure that allows the network can prolong the lifetime with limited energy that can be stored in sensor nodes. Generally, data communication is mainly responsible for exhausting the energy supply of the network, so that one efficient algorithm can apply for reducing data communication in network nodes is to compress the particular data before it is transmitted the information. The lightweight data compression is the most suitable method for the research area and capacity of the embedded devices. The many existing compression algorithm cannot be ported directly to sensor nodes because limited hardware portions are available such that program and data memory.

The Past few years a number of data compression techniques specifically designed for WSNs have been proposed. This section introduces the algorithm known as Lossless Entropy Compression (LEC) which has demonstrated the correlation between the data collected by the sensor nodes and the entropy compression algorithm [11]. The LEC algorithm can be adopted some terms: (a) to improve the compressibility of the sensed data and to reduce the dynamic range of source symbols. (b) The alphabet residues groups increase sizes exponentially. The LEC algorithm function is used in light weight compression for wireless sensor network since it is very simple and efficient. The LEC algorithm is a two stage process. On the first stage, unit-delay predictor is used to preprocess the sensed data and to generate the residues. For every acquisition m_i , the $d_i = x_i - x_{i-1}$ is generated. Where x_i are the readings of current sensor x_{i-1} is the past sensor readings. The d_i difference mentioned as input to the entropy encoder. In the second stage, two types of encoders are used to hold the temporal correlation in the sensed data and these encoders are named as static entropy encoder and adaptive entropy encoder. The Static entropy encoder performs compression of data without any loss of data and encoding differences d_i is based on statistical characteristics in accordance with the pseudo-code. The d_i is mentioned as a bit sequence is represented by c_i gives two parts as h_i and l_i .

$$c_i = h_i * l_i \quad (1)$$

$$l_i = (Index) l_{bi} \quad (2)$$

Where

$$b_i = \lceil \log_2(|d_i|) \rceil \quad (3)$$

$$Index = \begin{cases} d_i & d_i \geq 0 \\ (2^{b_i} - 1) + d_i & d_i \leq 0 \end{cases} \quad (4)$$

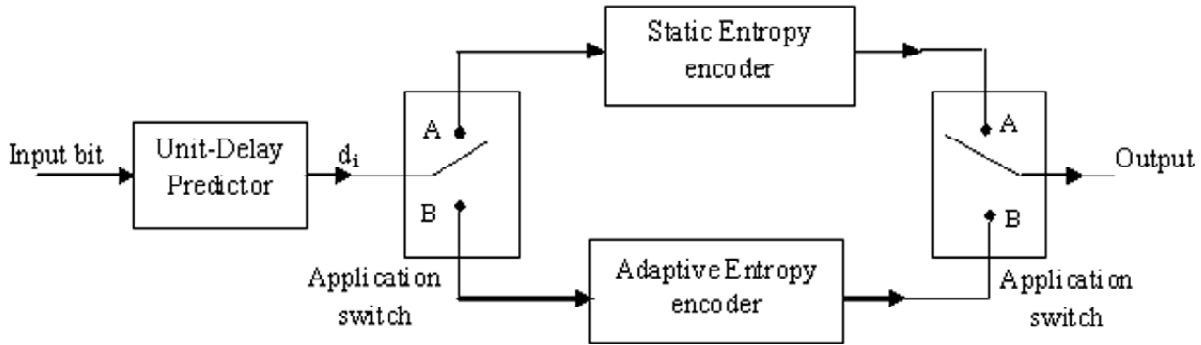

Figure 1: Block diagram of Entropy encoding algorithm

The equation (4) denotes the index position of each d_i in the group. (*Index*) I_{bi} mentioned as the binary representation of index values over b_i and it is the division of d_i . Then the adaptive entropy encoder can be achieved the highest compression ratio by saving the lot of energy in the WSN. The encoder operates in one pass and applied into multiple data type and this encoder is used in continuous monitoring system.

3.1.2. Fault Prediction Technique

In WSN fault appearing is the common issue due to various internal and external effects, such as environmental conditions, battery drain, malfunctioning, communication link failure, etc. These problems can produce incorrect data and reduces the reliability of the network, which may be affecting the Quality of Services (QoS). In general WSN have two types of faults namely Node fault and Network faults. Figure 2 represents the fault model in WSN. Routing is the one of the fundamental blocks in WSN. It is very essential for gathering sensor data, for delivering the software and configuration updates and for arranging among sensor nodes. Generally WSN should follow two types of steps. The first one is fault detection

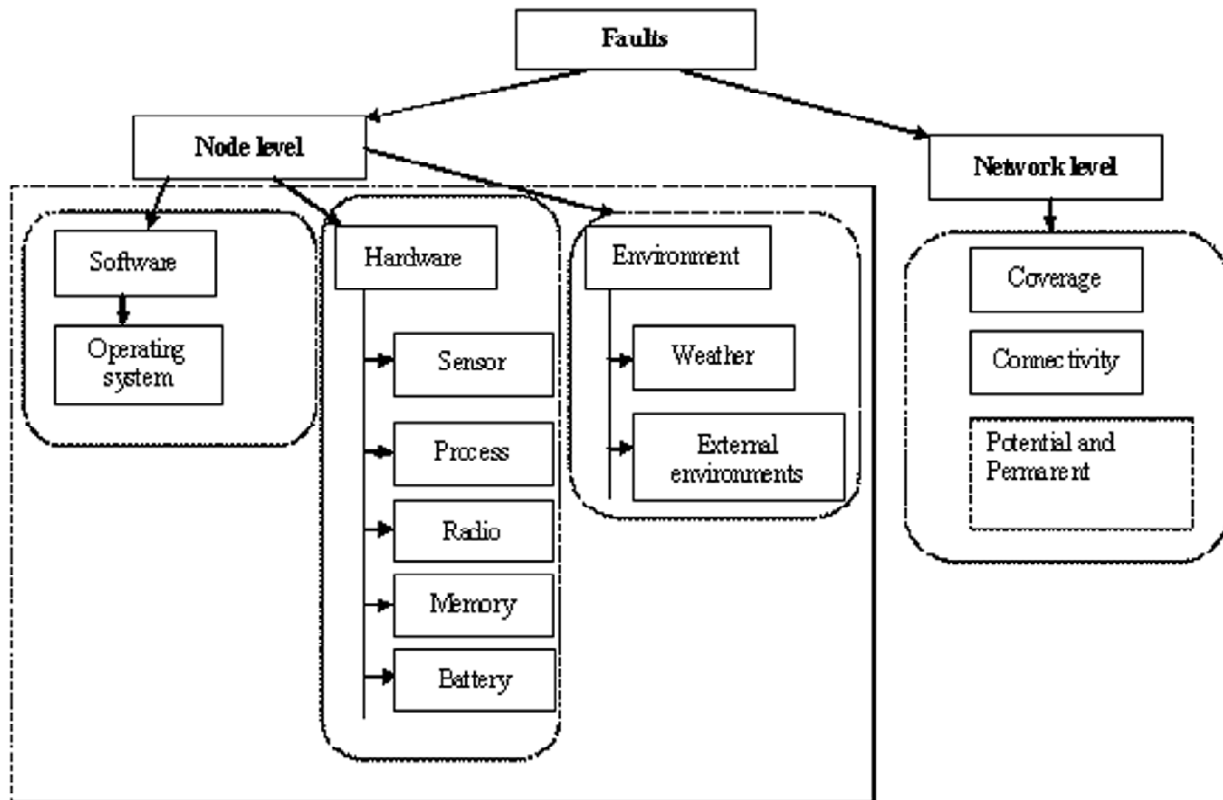

Figure 2: Fault Model

which is used to find specific functionality fault and predict the future function will be continuing to perform or not. The second step is fault recovery technique which is applied to the system is recovering with less energy consumption. Fault prediction techniques are two types: self diagnosis and cooperative diagnosis. In a sensor node, that fault can be determined and the node will adopt self-diagnosis detection. Battery depletion is the one of the main fault in the sensor node and other battery of the node can be predicted by using measuring current voltage. Another example is the detection of failed links between the communication nodes. In WSN, sensor nodes can be determine some failure links and some neighbor nodes will faults if the node does not receive a message from any other nodes. These types of faults can require cooperative diagnosis between the set of nodes. In this section we describe a new algorithm of fault management mechanism for WSN [12], each cluster has two cluster heads are Primary Cluster Head (PCH) and Backup Cluster Head (BCH). In each round the cluster nodes send the data to Primary Cluster Head at regular time interval. The use of the BCH is to check the availability of PCH by sending the message. After completing the rounds, the Backup Cluster Head does not get any message from PCH and BCH is disclosed that the PCH is failed and updated with non cluster head nodes. A new mechanism develops the network throughput and cost of energy will be decreased and it will maintain the reliable communication between the sensor networks.

4. SELF HEALING IN FPGA

In this paper, the objective of our research work is to develop the reconfigurable hardware to give an optimized self-healing ability for sensor nodes. The self-healing method is proposed in this section and it's to recover the WSN nodes when some hardware parts get faults. Self healing is used to discover, diagnose and react to network interruption. This component can identify the system malfunctions or failures and some other corrective actions to recover the sensor network or a node. The recovering process is an automatic process to recover the damages and to improve service availability of the network. The self-healing method is based on the reconfigurable hardware such as Field Programmable Gate Array (FPGA) and Field Programmable Analog Arrays (FPAA) [13]. This method will be working greatly in a geographical space and harsh area and to minimize the maintenance cost of the WSN. Two types of healing methodology are named as Node level and Network level. At the node level healing the FPGA can be designed redundant of modules of given functionality. If detected an error in the circuits, we use a Nios processor and it used to reconfigure the module. If the module has failed again Nios will reconfigure the same module. Finally, it

```

Healing()
{
  For (Each Faulty Sub Component of design)
  {
    Obtain configuration bitstreams ;
    While (timing constraints not met)
    {
      Replicate on Reconfigurable Logic and Transfer I/Os;
      Perform Timing analysis;
      If (timing constraints not met)
        Change the synthesis parameters;
    }
  }
}

```

Figure 3: Shows an algorithm of self healing method.

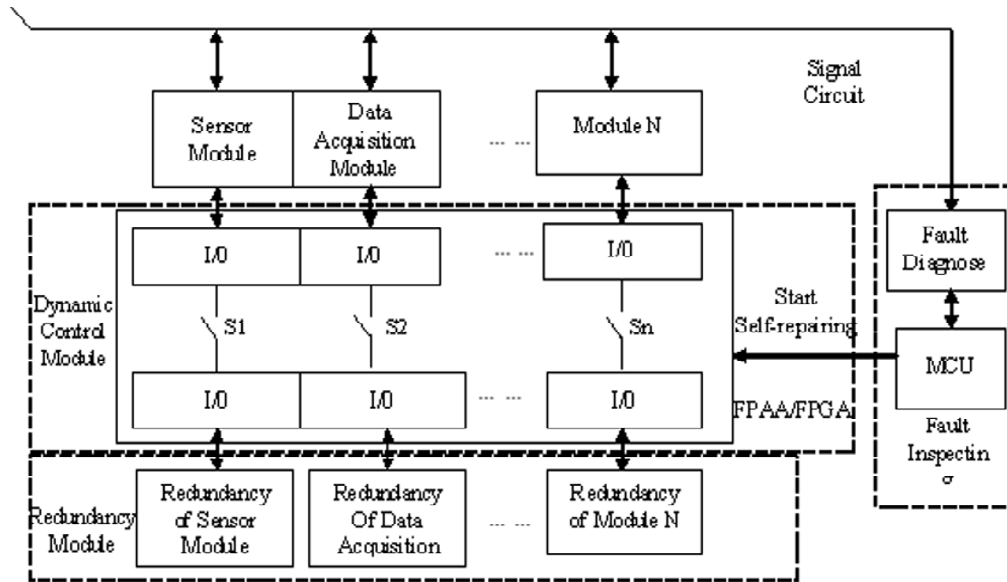

Figure 4: Redundancy based self-healing WSN node design

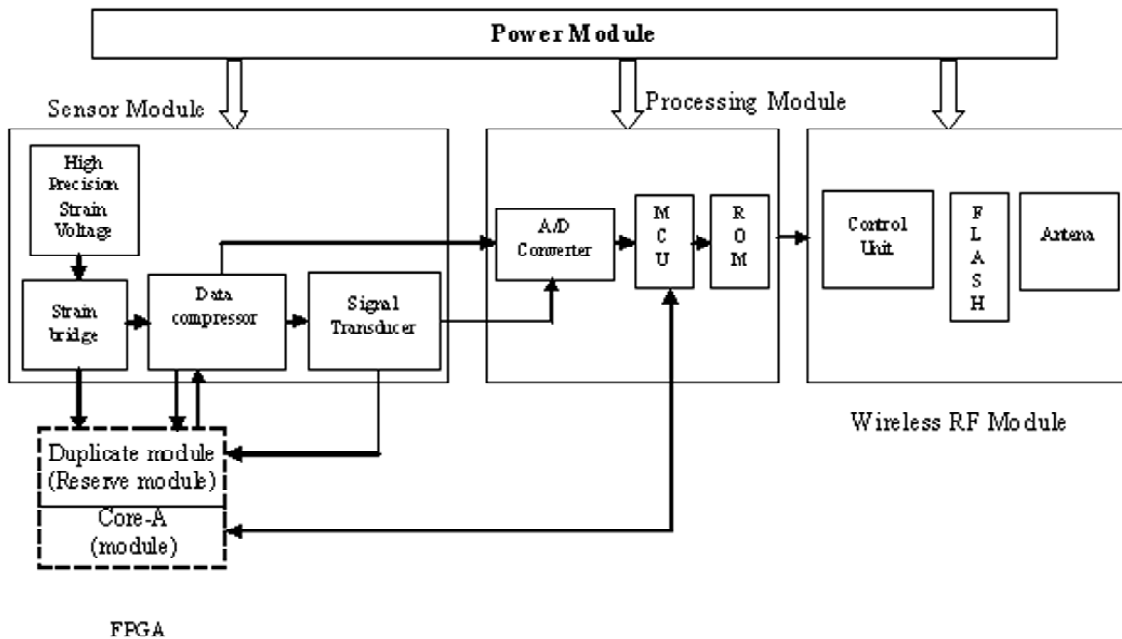

Figure 5: Proposed method of FPGA based self-healing WSN node design

gives the fault information to the wireless node. At the network level, the received fault information can send to the master base node and if we find the faults in the hardware, the master can reassign the task module. We have improved GUI, which control the master node and healing procedure. The healing algorithm can be written as shown in Figure 3.

Figure 4 and Figure 5 shows the redundancy-based self-healing node paradigm and FPGA based self-healing node design paradigm. WSN considers both analog and digital circuits and reconfigurable design is used to recognize the self-healing WSN node. Figure.3 follows the redundancy based self-healing design, redundant data module of some crucial circuits in the node design with FPGA to form self-healing nodes. In these designs, fault diagnostic software modules are implemented in the nodes and find the faults of circuits. The defective part is obtained using this software and redundancy modules can be replaced in failed parts of nodes.

In this section, Figure.5 shows the working of typical FPGA based wireless sensor healing method. The structure of WSN sensor node is designed by three nodes named as sensor module design, processing module design and wireless RF module design. In this section, sensor module usually designed by high precision supply circuit, data compressor and signal transducer. There are no added amplifiers and filters are required [13]. This module provides the high stable voltage to amplify and filter the output from bridge circuit. Processing modules and wireless RF modules are other parts of the wireless sensor nodes. The sensor modules are designed and connected to FPGA circuit. The processing modules are controlled by the whole node and process the data from the sensed data. The wireless RF module can be used to communicate the data from the base station. In our proposed work data compressor and signal transducer are digital circuits in the design of wireless sensor networks. Digital circuits are following design; an FPGA is accepted to a reconfigurable device to perform the self healing of the hardware circuits.

Our proposed method is to implement the FPGA based self-healing in the WSN node design. Using this FPGA based self-healing method, the main digital circuits are used in the WSN nodes are recognize the internal modules of reconfigurable design. Generally for WSN, when a hardware part has a failure, it usually disconnects the whole network and reorganize the networks using some hardware and software techniques. In our research work, the “backup module (Reserve module)” should maintain and store in the FPGA based self healing circuit design. When a certain parts of the circuit have failed, the FPGA design is dynamically reconfigured to use and we prefer the backup module to replace and apply the failed circuit. In this case, no extra redundant modules are needed, which is simplified using our backup module (Reserve module) design. The advantage of our technique is to improve the network lifetime with limited energy and reduce the maintenance cost. However, implementation area can be increased while we used our technique, but it is easy to use and maintain the networks compared to the existing problems in the WSN.

5. IMPLEMENTATION AND RESULT

A major consideration in any autonomous self-healing system is required for reconfigurable hardware-based self-healing node design. The self-healing system is implemented using the capabilities of the backup module to successfully reprogram a portion of an FPGA without using an external PC.

Implementation of WSNs for network load, the data transmission and channel modeling can be a complex task then gives the number of nodes can be taken in a sensor network. An FPGA is composed of an array of programmable components such as memories, logic gates, DSPs, etc. The FPGA design can be reconfigurable, high-performance and general purpose architectures can be designed [14]. The FPGA (statistically and dynamically) can offer reconfiguring parts and connected to the WSN nodes. The FPGA can provide the reduced power consumption and offer the chance to use hardware (HW) processing in a WSN node. It is very different from microcontroller allows implementation of cores. Our implementation method, the FLASH technology can be used to store the data and information dispersed on the FPGA. A FLASH is the nonvolatile memory and if the system power off, the content is kept on the system. FLASH FPGA application is the suitable technology for low power consumption such as WSNs. Let us follow the three power modes:

- **Active mode:** This mode gives maximum power consumption and performance when FPGA is the working full speed.
- **Sleep mode:** The I/O ports are turned off; the device of the internal parts should be maintained.
- **Shutdown:** The FPGA is off condition, the power consumption of the device is zero.

In existing method, SRAM memory is used in reconfigurable device, but does not offer low power applications. The FLASH non volatile memory provides lower power consumption.

5.1. Hardware environment

In our method, the hardware section divides of three FPGA boards and four DM2200 wireless nodes. The Xilinx ML501 Virtex-5 Development kit is the one of the FPGA board. In the FPGA, DM2200 is wireless modules of the wireless nodes. The DM2200 boards are mounted to the IM2200 interface. The DM2200 node can operate in the 914.5 MHz frequency and current draw a 5.0mA in a receive mode then 26.7 mA in a transmit mode. In a normal mode, the FPGA has accomplished the task of displaying received data. After the bit and data conversion, the result will be displayed. All the nodes are bound to the network and each FPGA is connected to the wireless node. Some nodes can be serves as a master base node and it will be performed the specific task.

5.2. Experimental Results

A major consideration in any independent, self-healing system is required time to heal. This system can be healed in real-time without any danger in circuits. The system prototype can be designed of three nodes. Each node is executing one of three processing tasks. We divide our results into two sections: Node level healing and Network level healing. Figure 6 shows the block diagram of proposed method.

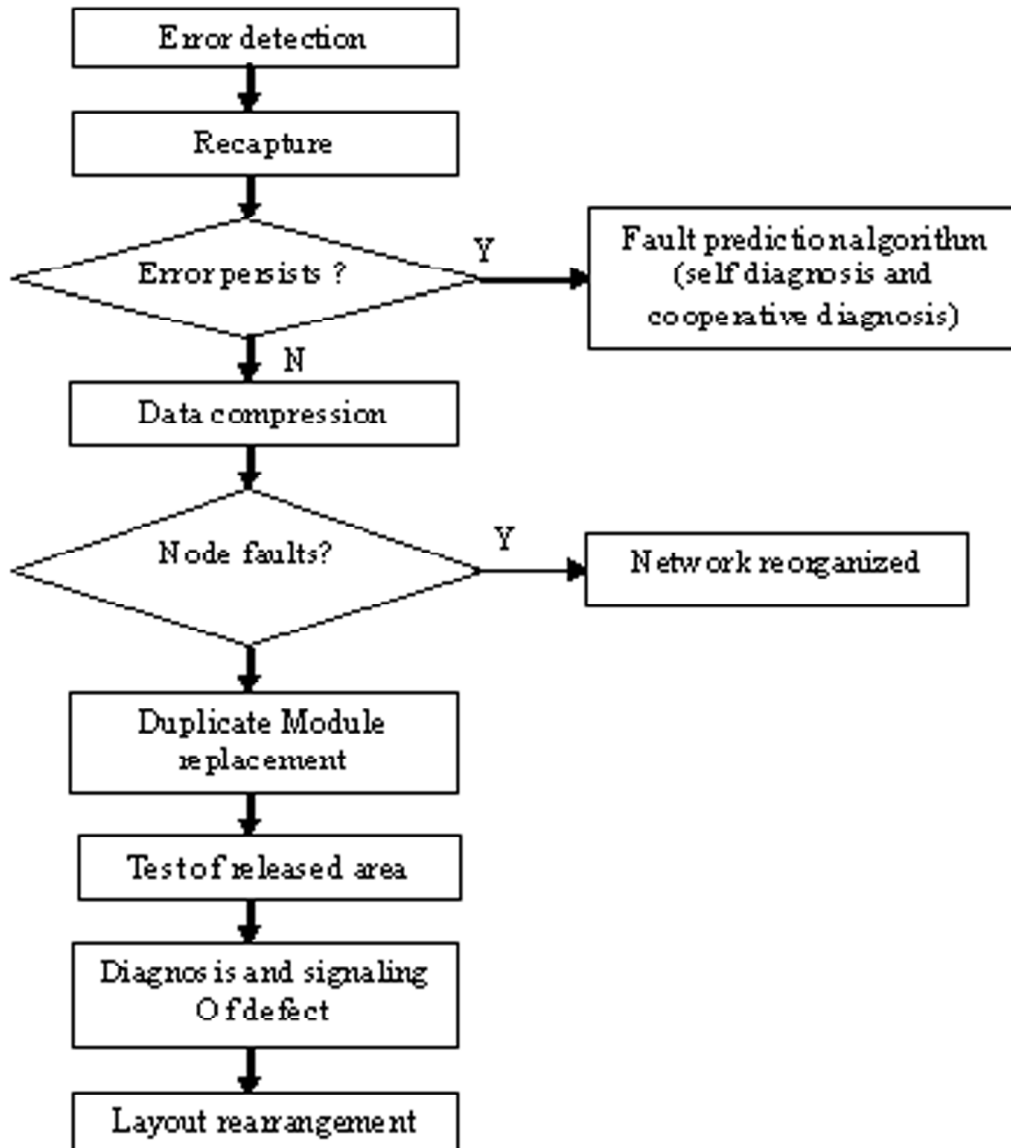

Figure 6: Working flowchart

- (i) Node level healing results: In this section Nios processor can be used. When execution modules are failed, the Nios processor will be partially reconfiguring the same module. The partial reconfiguration may not work always in the healing process. Nios enables to use other backup module of identical functionality and reconfiguration time for failed effort and the time taken by software to enable the backup module. It is required to reconfigure the FPGA for the full process as well as partial process. Partial reconfiguration time of the FPGA is nearly 45 times faster than entire process. The power will be consumed lower while using a backup module.
- (ii) Network level healing results: In the network level healing method, when disconnected the node from the system and time taken for the tasks to be re-assigned. In this healing GUI can be used. When the GUI fails to receive data from disconnected node, it re-assign and executed by failure node to working node. The time taken to be reassigned the task depends the speed of the network. When disconnecting the network, the GUI takes an average time 4.98 seconds to re-assign the task to another node.

5.3. Power consumption evaluation

This experiment is used to evaluate the power consumption of the particular self healing nodes. Regarding our experiments, the FPGA based self-healing consumes lower energy compared than FPAA based self-healing and Redundancy based self-healing. This module cost is more when it can be adopted. The power consumption of the FPGA based self-healing based node is supplied power by two 1,800 mA batteries and the node sample 15s an interval of 1 hour of every day. The work will continue more than 10 months. It

Node design	Results	
	Working Voltage (V)	Working State (mA)
Redundancy based Self-healing node design	3.3	75.5
FPAA based Self-healing node design	3.3	62.7
FPGA based self healing method (Proposed)	3.3	31.7

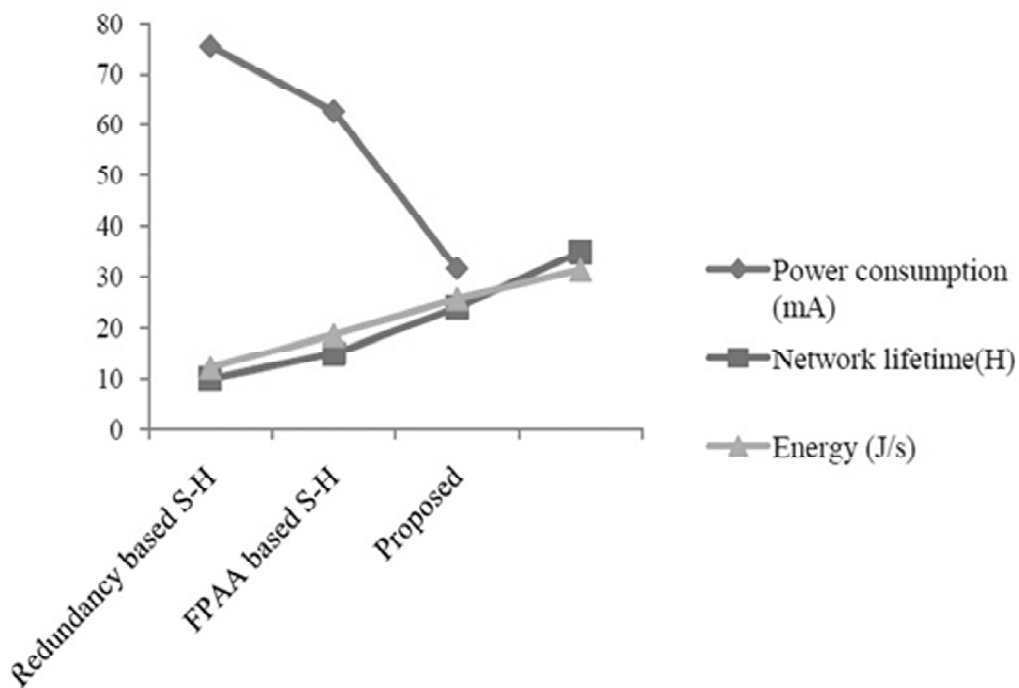

Figure 7: Experimental Results

used for some applications such as health monitoring applications, industrial monitoring process, home automation, healthcare applications, etc. The power consumption of the FPGA based self-healing is acceptable and compared than existing methods [13]. The table.1 Estimates the power consumption results and Figure 7 shows the experimental results.

6. CONCLUSION

To compile our proposed project, it is designed of FPGA based self-healing nodes made up low power processors and it will support multiple interfaces and strong cryptography implementation. This paper involves a study on FPGA based self-healing method for wireless sensor networks (WSNs). FPGA based healing method designed by sensor module, processing module and wireless RF module. In advance as of now our techniques have been developed using fault prediction and lightweight compression solution to evaluate the faulty circuit and reconfigure using FPGA. To exhibit our work we use backup module (Reserve module) data for reconfiguration part while getting faulty circuit. The technique has disservice which, we need more area while using the backup module in our work. As there is an influence of energy consumption, network lifetime will be amplified and lessens the power consumption of sensor networks. From comparison between redundancy based self-healing, FPAA based self-healing and FPGA based self-healing, we show low power characteristics of WSNs. Our demonstration is that, energy increases and serves as elongate life time network. It is employed for many applications of WSNs, such as structural health monitoring, transmitting devices, industrial control, multimedia applications, environmental monitoring, safety and security applications for sensor nodes, healthcare applications, etc

REFERENCES

- [1] Dame Diongue, Ousmane Thiare. An Energy Efficient Self-healing Mechanism for Long Life Wireless Sensor Networks. 2014.
- [2] M. Ceschia et al., "Identification and Classification of Single-Event Upsets in the Configuration Memory of SRAM Based FPGAs", *IEEE Transactions on Nuclear Science*, Vol.50, No. 6, pp. 2088-2094, Dec. 2003.
- [3] M. Bellato et al., "Evaluating the effects of SEUs affecting the configuration memory of an SRAM-based FPGA", *Proc.Design, Automation and Test in Europe*, pp. 584-589, 2004.
- [4] E. Fuller et al., "Radiation Testing Update, SEU Mitigation, and Availability Analysis of the Virtex FPGA for Space Reconfigurable Computing", *Proc. Military and Aerospace Applications of Prog. Logic Devices Conf.*, 2000.
- [5] M. French et al., "Radiation Mitigation and Power Optimization Design Tools for Reconfigurable Hardware in Orbit", *Proc. Earth-Sun System Technology Conference*, 2005.
- [6] C. Carmichael et al., "SEU Mitigation Techniques for Virtex FPGAs in Space Applications", *Proc. Military and Aerospace Applications of Prog. Logic Devices Conf.*, 1999.
- [7] Yick, J.; Mukherjee, B.; Ghosal, D. Wireless sensor network survey. *Comput. Netw.* **2008**, *52*, 2292–2330.
- [8] Dressler, F. Benefits of Bio-Inspired Technologies for Networked Embedded Systems: An Overview. In *Proceedings of Dagstuhl Seminar 06031 on Organic Computing-Controlled Emergence*, Erlangen, Germany, 15–20 January 2006; pp. 1–4.
- [9] Yongxian Song, Ting Chen, Juanli Ma, Yuan Feng and Xianjin Zhang. Design and Analysis for Reliability of Wireless Sensor Network. *JOURNAL OF NETWORKS*. Vol. 7, No. 12, 2012.
- [10] L. Sterpone and M. Violante. Analysis of the Robustness of the TMR Architecture in SRAM-Based FPGAs. *IEEE TRANSACTIONS ON NUCLEAR SCIENCE*, Vol. 52, No. 5, 2005.
- [11] V. Snaesel et al. A Simple Data Compression Algorithm for Wireless Sensor Networks. Springer-Verlag Berlin Heidelberg. pp. 327–336. 2013.
- [12] G. Vennira Selvi , R. Manoharan. Cluster Based Fault Identification And Detection Algorithm For WSN- A Survey. *International Journal of Computer Trends and Technology (IJCTT) – volume 4 Issue10 – Oct 2013*.
- [13] Shenfang Yuan, Lei Qiu, Shang Gao, Yao Tong and Weiwei Yang. Providing Self-Healing Ability for Wireless Sensor Node by Using Reconfigurable Hardware. *Sensors* 2012, *12*, 14570-14591; doi:10.3390/s121114570.
- [14] Liao.et al., FPGA based wireless sensor node with customizable event-driven architecture. . *EURASIP Journal on Embedded Systems* 2013, 2013:5 .

