

International Journal of Control Theory and Applications

ISSN : 0974-5572

© International Science Press

Volume 10 • Number 22 • 2017

Analysis of a Passive Filter with Improved Power Quality for PV Applications

S. Sanjunath¹, Meenakshi Jayaraman² and Sreedevi V. T.³

¹ M.Tech. Power Electronics and Drives, School of Electrical Engineering, VIT University, Chennai, India, 600127

² Assistant Professor, School of Electrical Engineering, VIT University, Chennai, India, 600127

E-mail: jayaraman.meenakshi@gmail.com

³ Professor, School of Electrical Engineering, VIT University, Chennai, India, 600127

Abstract: Renewable energy based distribution systems use pulse width modulation based voltage source inverters to convert the generated DC power to AC power before connecting to the grid or standalone load. Harmonics generated by such inverters may affect the quality of the electrical network and alter its performance. This paper focuses on the design of LTCL passive filter for harmonic reduction in inverters. The design procedure is included for switching frequencies of 2 kHz, 5 kHz and 10 kHz. Sine-Sawtooth modulation strategy is employed to generate switching pulses for the inverter. A comparison on the performance of the LTCL filter in reducing harmonics from the inverter output is carried out for various switching frequencies. Further, the work assesses the total harmonic distortion and waveform quality of the standalone inverter without any filter, with a L filter and an LTCL filter. It is found that the LTCL filter operating at a higher switching frequency produces less harmonic distortion with reduced filter size components and improves the quality of the output waveforms of the inverter. Results are verified using simulations done in MATLAB-Simulink simulation platform.

Key Words: Photovoltaic (PV), Pulse Width Modulation (PWM), Harmonics, Total Harmonic Distortion (THD)

1. INTRODUCTION

Power Converters play a vital role in standalone and grid connected applications. Fig. 1 shows a generic block diagram of a photovoltaic (PV) based standalone/grid connected system [1],[2]. The generated DC power from PV source is first maintained or regulated at a constant value which is then transformed into the system DC voltage level using a DC to DC converter. As most of the loads used nowadays are AC type loads, an inverter is essential to convert the DC voltage into AC voltage.

The DC to AC converter, also known as an inverter is an important component in a PV based renewable energy system that uses various Pulse Width Modulation (PWM) strategies for switching the DC power into controlled AC power. PWM switching is most widely used since it is an easiest and an efficient way to generate AC power, allowing feasible control of output voltage and frequency [3]. All the PWM methods intrinsically

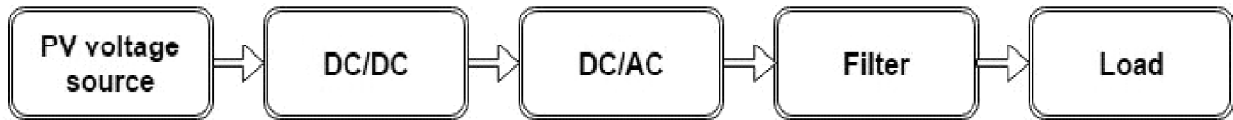

Figure 1: Block diagram of grid-connected PV system

generate harmonics and noise as they involve fast switching of semiconductor switches [4],[5]. Hence external filters are added in a standalone/grid connected system in order to reduce harmonics.

Many filter types are proposed in the literature for reduction of harmonics from PWM inverters [6],[7]. Though these filters intend to suppress harmonics and carry their own advantage, but issues arise when the size of the designed filter becomes too large. The traditional filter in PV based inverter systems is the L type filter [8]. Though the filter is very simple, yet it is restricted in use due to its larger size. LC type second order filters are another popular solution to mitigate harmonics [9]. These filters have been widely used in drive based applications when the voltage harmonic reduction is the target. The LCL filter finds to be a better solution compared to L type and LC type filters to meet the grid standards with smaller size and cost [10],[11]. However a system with a third order filter like LCL filter is prone to stability issues. Also, the design procedure of the LCL filter is restricted by the switching frequency of the inverter. An LLCL filter is another popular filter proposed to mitigate harmonics [12],[13]. A LC series resonant circuit is tuned at the switching frequency to provide a low impedance path to attenuate harmonics. However a LLCL filter has a reduction in the harmonic attenuation rate at high frequencies. Higher order filters like LCCL, LTCL etc. are introduced as good filtering solutions to achieve reduction in filter size [14],[15], though it is slightly difficult to design their parameters. Nowadays, more focus is towards parameter optimization of such higher order filters [16].

In this paper, the performance of a LTCL filter [14] is analysed for a standalone PV system. The design procedure of the LTCL filter for a standalone inverter is carried out for switching frequencies of 2 kHz, 5 kHz and 10 kHz. Further, the paper aims to compare the performance of the LTCL filter with a traditional L filter. The work evaluates the Total Harmonic Distortion (THD) of a standalone inverter without any filter, with a L filter and an LTCL filter for various switching frequencies. It is found that the LTCL filter operating at a higher switching frequency produces less harmonic distortion on inverter output and uses a very less size of filter components. Though it is a higher order filter, yet it is economical as the total value of inductance used in the LTCL filter is the same as that of a L filter. Sine-Sawtooth modulation is used to generate gating pulses for the inverter.

This paper is organized as follows. Section II summarizes the basic concepts of SPWM. In Section III, the design of LTCL filter for harmonic reduction is discussed. Section IV shows the simulation results without filter, with L filter and with a LTCL filter. Finally, Section V presents the conclusion.

2. BASIC CONCEPTS OF SPWM AND INVERTER HARMONICS

The most common switching technique used in inverters is the SPWM strategy [3],[4]. The comparison of a sinusoidal reference signal with a carrier wave at switching frequency generates switching pulses using this technique. When the modulating signal is a sinusoid of amplitude A_m , and the amplitude of the carrier is A_c , the modulation index is given by the ratio $m=A_m/A_c$. The frequency of reference signal determines the inverter output line frequency. Its peak amplitude controls the modulation index M which in turn controls the inverter output voltage. The carrier frequency determines the number of pulses generated per half-cycle. Two switches of the same leg cannot conduct at the same time. SPWM using saw tooth carrier wave is shown in Fig. 2.

Switching operation involved with SPWM technique employed in inverters result in harmonics. In this process, the switching frequency employed is very high such that large amount of harmonics will be generated

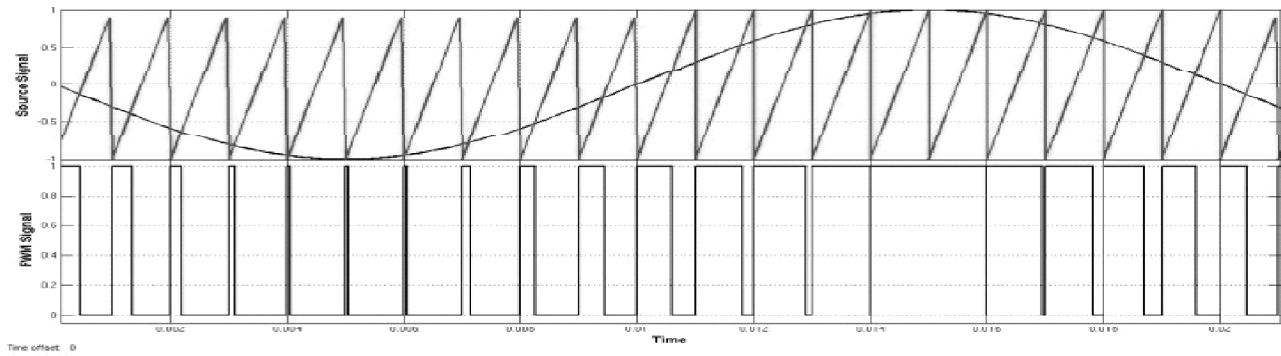

Figure 2: Sinusoidal PWM with sawtooth carrier

at the switching instants and at its multiples. These higher order harmonics are attenuated using passive filters. In this paper, an LTCL filter is designed to filter out the PWM inverter harmonics.

3. ANALYSIS OF LTCL FILTER

Fig. 3 presents the structure of a LTCL filter [14]. It comprises of a traditional LCL filter with multiple tuned LC trap branches. The trap branches are tuned at a particular frequency to provide negligible impedance path for that particular frequency. The selected frequency is usually the multiples of the switching frequency. In Fig. 3, L3 and L4 are the inverter side and grid side inductances. C3 is the LCL filter capacitor. L1, C1 and L2, C2 are two LC filter trap branches added to provide better harmonic attenuation. The LTCL filter is connected to the inverter output and the system is connected to a standalone load. v_i represents the inverter output voltage which is basically the SPWM output and i_L is the current drawn by the load.

The transfer function of the LTCL filter with two trap branches is given by Eq. (1).

$$\frac{i_L(s)}{v_i(s)} = \frac{L1L1C1C2s^4 + (L1C1 + L2C2)s^2 + 1}{Ps^7 + Qs^5 + Rs^3 + Ss} \quad (1)$$

where P, Q, R and S are given as

$$P = L3L4C3L1C1L2C2$$

$$Q = [(L1 + L2)L3L4C1C2 + (L1C1 + L2C2)L3L4C3 + (L3 + L4)L1C1L2C2]$$

$$R = [(C1 + C2 + C3)L3L4 + (L3 + L4)(L1C1 + L2C2)]$$

$$S = (L3 + L4)$$

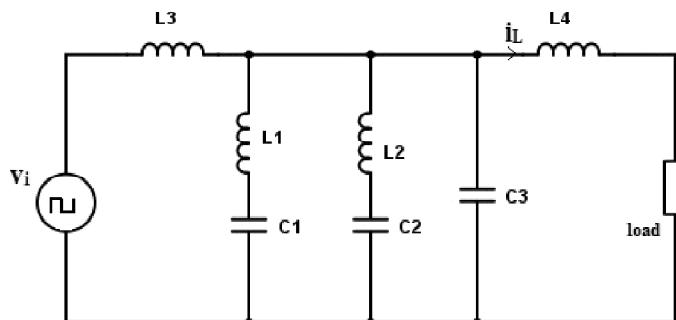

Figure 3: LTCL filter connected to an inverter

The first step in the design of the LCL filter with the two trap branches include design of total capacitance, LCL filter capacitance C_3 , trap branch capacitances, C_1 and C_2 . With the reactive power absorbed at rated conditions the sum of capacitance can be determined as the sum of the three capacitance values used in the filter circuit which can be equated to xC as given by Eq. (2), where C is the total capacitance of the LTCL filter.

$$C_{total} = C_1 + C_2 + C_3 = xC \quad (2)$$

where x is less than 1 [14]. The maximum value of capacitor is restricted by Eq. (3).

$$C = \frac{0.05P_r}{v_0^2 2\pi f_0} \quad (3)$$

where P_r is the rated power and v_0 is the fundamental RMS value of voltage across the load. The decrease of power factor at the rated conditions is used to limit the value of capacitor (should be less than 5%) [15].

The next step is the design of inductance value for the LTCL filter. A reasonable current ripple is chosen for designing the inverter side inductance L_3 . The LTCL filter can support a larger current ripple up to 60% [14]. This helps in decreasing the value of the converter side inductance. The maximum value of current ripple is arrived at using Eq. (4).

$$\frac{\Delta I_{max}}{I_{ref}} = \frac{1}{4} \frac{V_s}{L_3 f_{swit} I_{ref}} \quad (4)$$

where ΔI_{max} is the maximum ripple current, I_{ref} is the rated reference peak current. The maximum ripple should lie within the limits of 20% - 60%. V_s represents the input voltage of the inverter and f_{swit} is the switching frequency of the inverter.

For the design of the trap branch values, primarily the capacitor in each branch should satisfy Eq. (2). Each LC trap branch should resonate at the frequency of significant harmonic and it is given by Eq. (5).

$$f_{reso} = \frac{1}{2\pi \sqrt{L_m C_m}} \quad (5)$$

f_{reso} is specific frequency and $f_{reso} = m f_{swit}$

$m = 1, 2, 3$, etc. The trap branch inductor and capacitor gives rise to resonance that needs to be damped. A damping resistance is connected in series with the reactive elements in each trap branch as given by Eq. (6).

$$R_m = \frac{\sqrt{L_m / C_m}}{Q} \quad (6)$$

where R_m is the equivalent resistance of the L_m - C_m trap branch. The equivalent resistance of the trap branch itself would be sufficient to damp the oscillations. The value of Q is limited between 10 and 50 [12], [14].

Once the capacitor values for each trap branch is designed, it is easy to obtain the value of C_3 using Eq. (2). C_3 is designed in order to attenuate the harmonics in the high frequency band.

The selection of load side inductance L_4 takes into consideration the attenuation of harmonics around multiples of the switching frequency. It is designed such that $L_4 = a L_3$, where “ a ” called the inductance ration

factor is limited between 0 and 1 [11],[12]. It is desirable to reduce the load side inductance in order to achieve reduction in total inductance of the LTCL filter.

The resonant frequency of the LTCL filter is given by Eq. (7).

$$f_{r_low} = \frac{1}{2\pi} \sqrt{\frac{L3 + L4}{L3L4C_{total}}} \quad (7)$$

With all the designed parameters based on steps explained above, the resonant frequency is calculated. This value is usually restricted to five times the line frequency and half the inverter switching frequency. However, this constraint cannot be simply used to the LTCL filter as there are three resonance frequencies for LTCL filter. Finding the exact characteristic equation is quite difficult, so an approximate estimate of lowest resonance frequency is chosen.

Table I shows the system parameters for which the LTCL filter is designed.

**Table I
Simulation Parameters**

<i>Parameter</i>	<i>Value</i>
Input voltage	325 V
Output voltage	230 V
Rated power	1.15 kW
Output frequency	50 Hz
Load	R = 46 Ω , L = 12 mH
Modulation index	1

Table II shows the details of the LTCL filter designed for the standalone inverter based on system parameters shown in Table I.

**Table II
Filter Parameters**

<i>Parameter</i>	<i>Design constraint/Formulae</i>	<i>Calculated value</i>
L3	42% ripple current	2.738mH
Ctotal	5% of rated power	3.11383 μF
C1	Choosing C1 as 1 μF	1 μF
L1	According to Eq. (4)	0.2533mH
R1	Taking Q as 20 and considering Eq. (6)	0.7957Ω
C2	Choosing C2 as 1 μF	1 μF
L2	According to Eq. (5)	0.063325mH
R2	Taking Q as 20 and considering Eq. (6)	0.3978 Ω
C3	Calculated using Eq. (2)	1.11382μF
L4	L4 = 0.5 L3	1.369mH

With the filter designed with above values, the lowest characteristic resonance frequency is calculated as $f_{r_low} = 2985.501$ Hz which obeys the resonant frequency constraint mentioned above. The total inductance value

obtained for different switching frequencies is shown in Table III. It can be seen that with higher switching frequency, the filter size is reduced. In a similar fashion, a L type filter is designed for the standalone inverter. The total inductance obtained with the LTCL filter for different switching frequencies are considered for the inductance value in the L filter.

Table III
Total inductance value for different switching frequencies

<i>Switching frequency</i>	<i>Total Inductance (mH)</i>
2 kHz	22.7793
5 kHz	7.5373
10 kHz	4.4236

With the calculated filter parameter values as shown in Table II and Table III, Bode plots are drawn considering three switching frequencies, 2 kHz, 5 kHz and 10 kHz as shown in Figs. 4(a), 4(b) and 4(c) respectively.

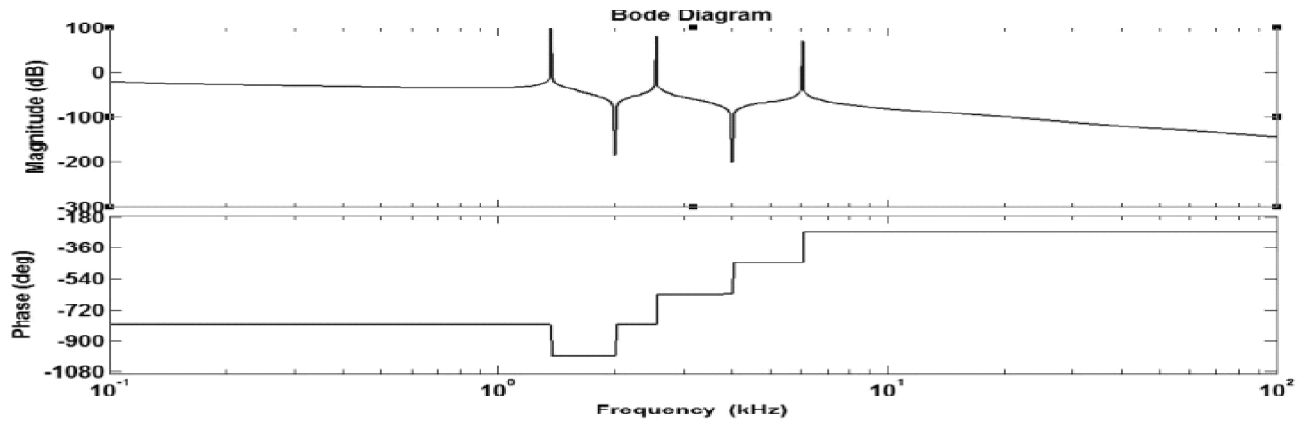

Figure 4(a): Bode diagram of LTCL filter for 2 kHz

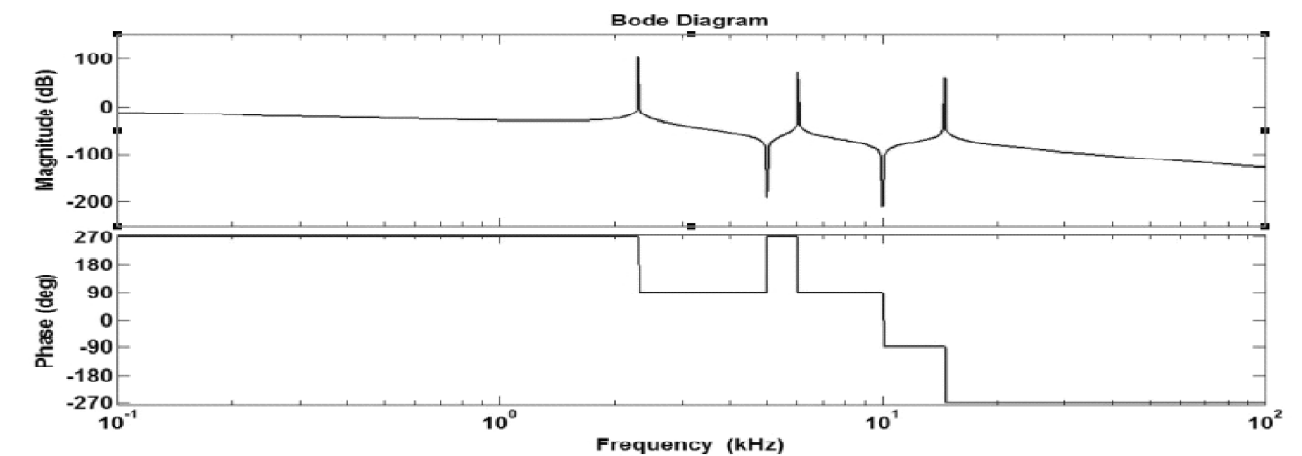

Figure 4(b): Bode diagram of LTCL filter for 5 kHz

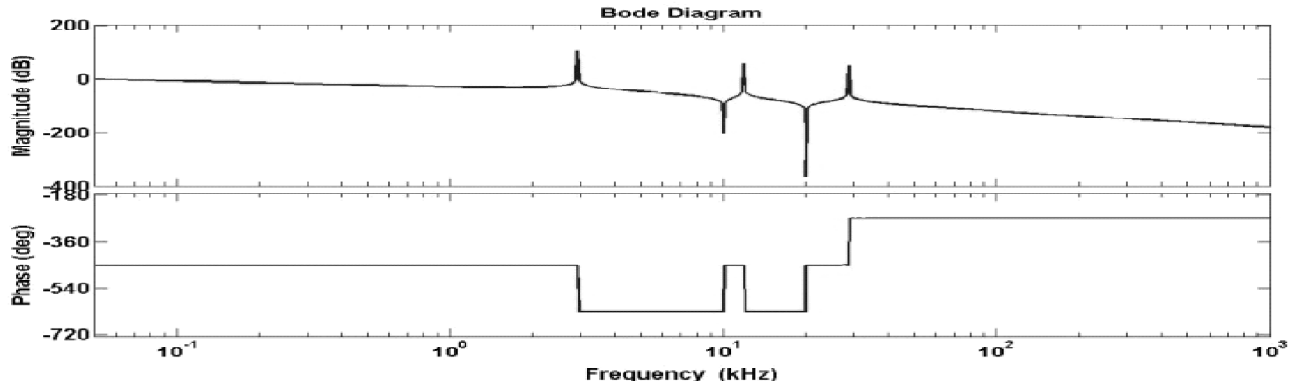

Figure 4(c): Bode diagram of LTCL filter for 10 kHz

It can be observed from all the Bode plots that the LTCL filter has got almost same frequency response characteristics with three resonant frequencies. The LTCL filter is designed to provide good harmonic attenuation for all the three scenarios with 2 kHz, 5 kHz and 10 kHz. In high frequency band, the filter provides higher harmonic attenuation when operated at high frequency as seen from Fig. 4(c) when compared to Fig. 4(a) and Fig. 4(b).

4. SIMULATION RESULTS

To test the performance of the inverter with LTCL filter, simulations are carried out on an inverter supplying a standalone load using MATLAB-Simulink. The specifications are listed in Table I. The simulations are carried out for switching frequencies of 5 kHz and 10 kHz for a modulation index of unity. This paper uses sine-sawtooth PWM to generate inverter switching pulses.

Results of inverter without filter

The inverter output voltage is shown in Fig. 5. PWM inverter output is obtained without filter which is as expected. The harmonic spectrum is depicted in Fig. 6. The measured THD is 52.39%. The magnitude of harmonics present around 10 kHz and its multiple, 20 kHz, as a percentage of fundamental is shown in Fig. 7(a) and Fig. 7(b) respectively. It can be seen that the harmonics is highly concentrated near to the switching frequency of 10 kHz and twice the switching frequency of 20 kHz.

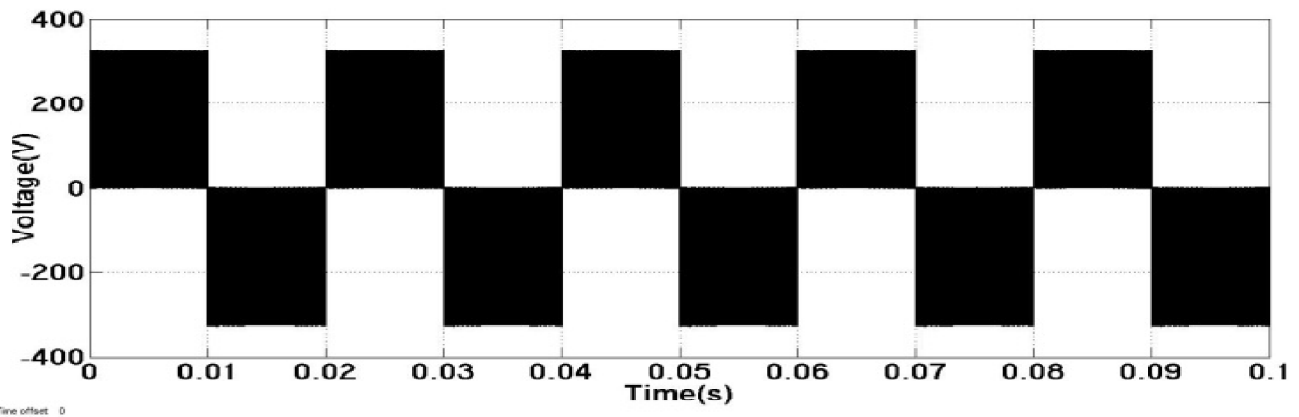

Figure 5: Voltage waveform without filter

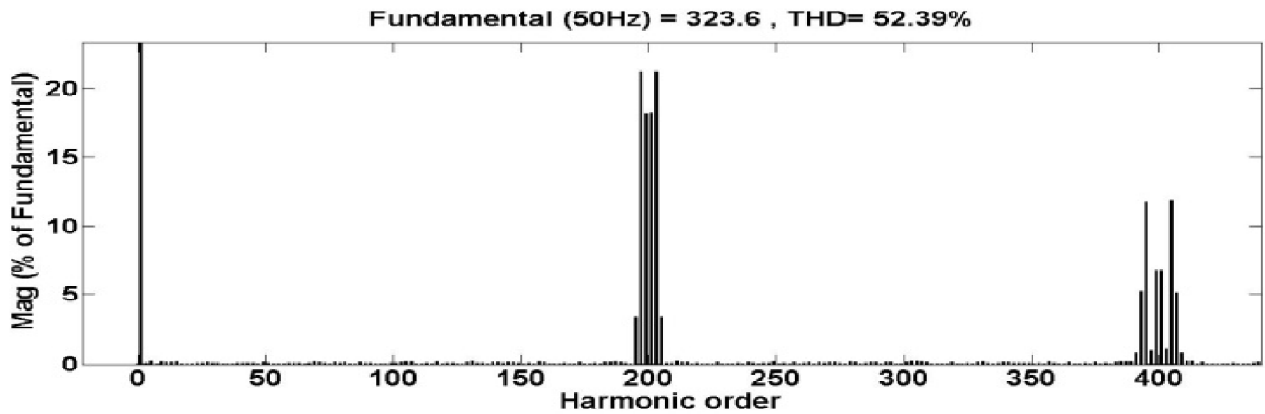

Figure 6: Voltage THD without filter

9650 Hz (h193) :	0.01%	-6.2°
9700 Hz (h194) :	0.00%	0.0°
9750 Hz (h195) :	3.37%	176.5°
9800 Hz (h196) :	0.00%	-57.5°
9850 Hz (h197) :	21.17%	176.5°
9900 Hz (h198) :	0.00%	-19.0°
9950 Hz (h199) :	18.16%	176.4°
10000 Hz (h200) :	0.00%	2.3°
10050 Hz (h201) :	18.20%	-3.6°
10100 Hz (h202) :	0.00%	8.2°
10150 Hz (h203) :	21.15%	-3.6°
10200 Hz (h204) :	0.00%	24.8°
10250 Hz (h205) :	3.39%	-3.7°
10300 Hz (h206) :	0.00%	0.0°
10350 Hz (h207) :	0.09%	-4.3°

Figure 7(a): Harmonics around switching frequency without filter for 10 kHz

19600 Hz (h392) :	0.00%	0.0°
19650 Hz (h393) :	5.20%	-7.1°
19700 Hz (h394) :	0.00%	0.0°
19750 Hz (h395) :	11.78%	-7.1°
19800 Hz (h396) :	0.00%	201.1°
19850 Hz (h397) :	0.92%	-7.2°
19900 Hz (h398) :	0.00%	-48.5°
19950 Hz (h399) :	6.84%	172.8°
20000 Hz (h400) :	0.00%	-2.2°
20050 Hz (h401) :	6.84%	-7.2°
20100 Hz (h402) :	0.00%	17.8°
20150 Hz (h403) :	1.04%	172.9°
20200 Hz (h404) :	0.00%	161.4°
20250 Hz (h405) :	11.86%	172.7°
20300 Hz (h406) :	0.00%	173.2°
20350 Hz (h407) :	5.14%	172.7°

Figure 7(b): Harmonics around twice switching frequency without filter for 10 kHz

Similar simulation are carried out with an inverter for 5 kHz. The voltage waveforms and harmonic spectrum are captured. The measured THD with 5 kHz is 52.5% with majority harmonics near and around 5 kHz.

Results of inverter with L filter for 5 kHz

The inverter output voltage with the L filter for 5 kHz is shown in Fig. 8. The inverter output is distorted with the L filter. The harmonic spectrum is depicted in Fig. 9. The measured THD is 32.52%. It can be seen that the magnitude of harmonics is slightly decreased with the designed L filter when compared to that without filter.

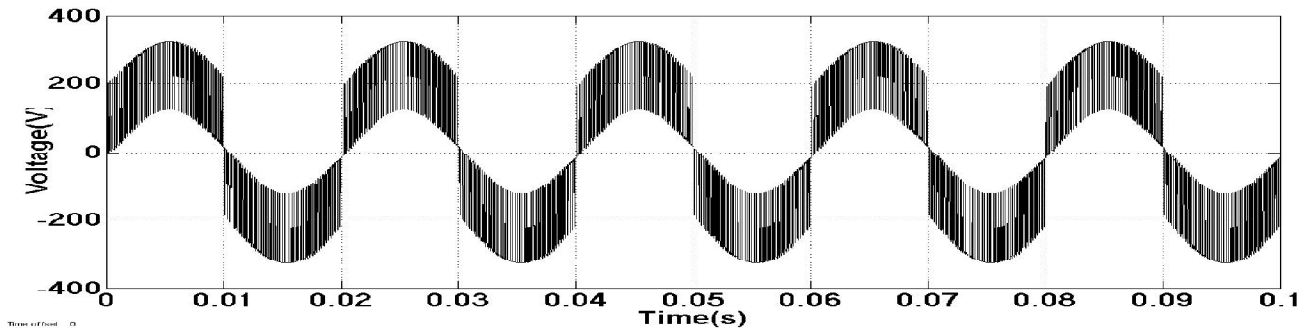

Figure 8: Voltage waveform with L filter for 5 kHz

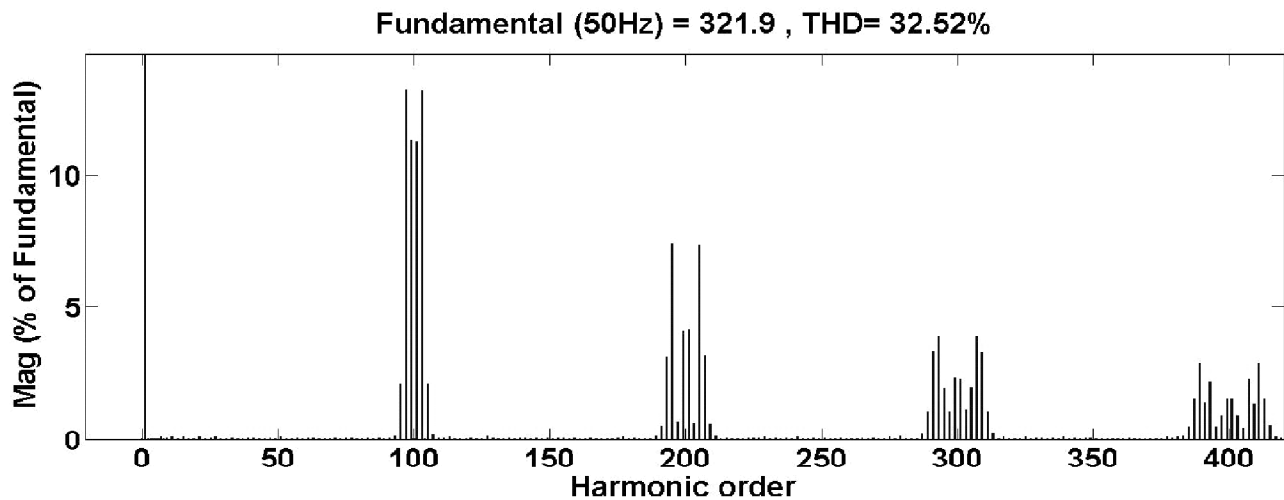

Figure 9: Voltage THD with L filter for 5 kHz

Results of inverter with L filter for 10 kHz

The inverter output voltage with the L filter for 10 kHz is shown in Fig. 10. The inverter output is distorted with the L filter. The harmonic spectrum is depicted in Fig. 11. The measured THD is 38.41%. It can be seen that the magnitude of harmonics is slightly decreased with the designed L filter when compared to that without filter. However the THD is slightly greater compared to that with L filter for 5 kHz. This is because for comparison of the performance of the filters, the same inductance value is considered for L and LTCL filters for a particular switching frequency.

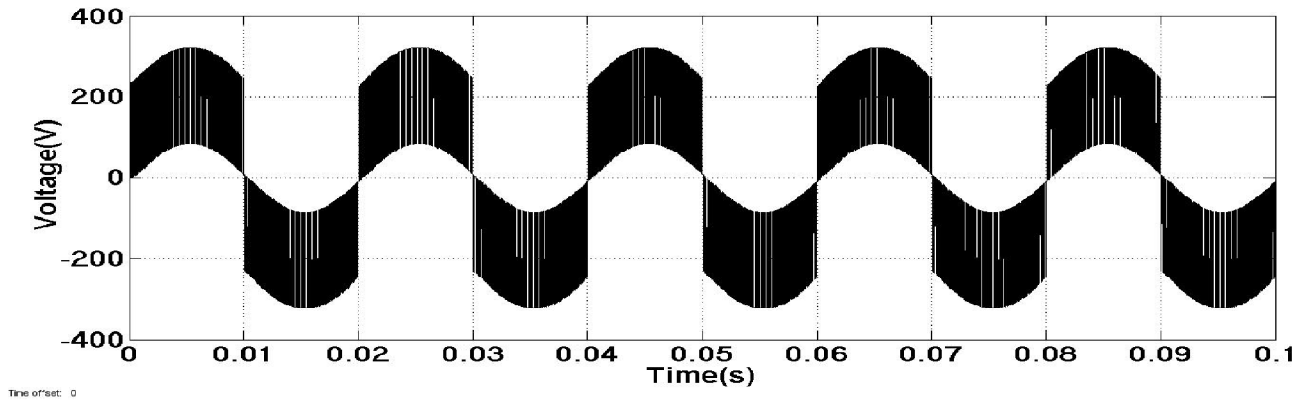

Figure 10: Voltage waveform with L filter for 10 kHz

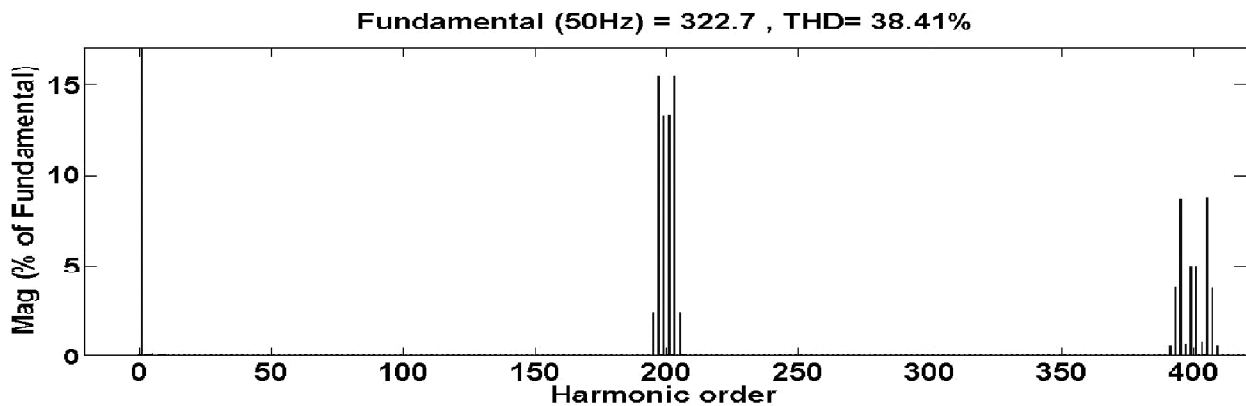

Figure 11: Voltage THD with L filter for 10 kHz

Results of inverter with LTCL filter for 5 kHz

The inverter output voltage with the LTCL filter for 5 kHz is shown in Fig. 12. The inverter output has got a sinusoidal shape after connecting the filter. The harmonic spectrum is depicted in Fig. 13. The measured THD is 10.52%. The magnitude of harmonics present around 5 kHz and its multiples as a percentage of fundamental is shown in Fig. 14(a) and Fig. 14(b) respectively. It can be seen that the magnitude of harmonics is very much decreased with the LTCL filter.

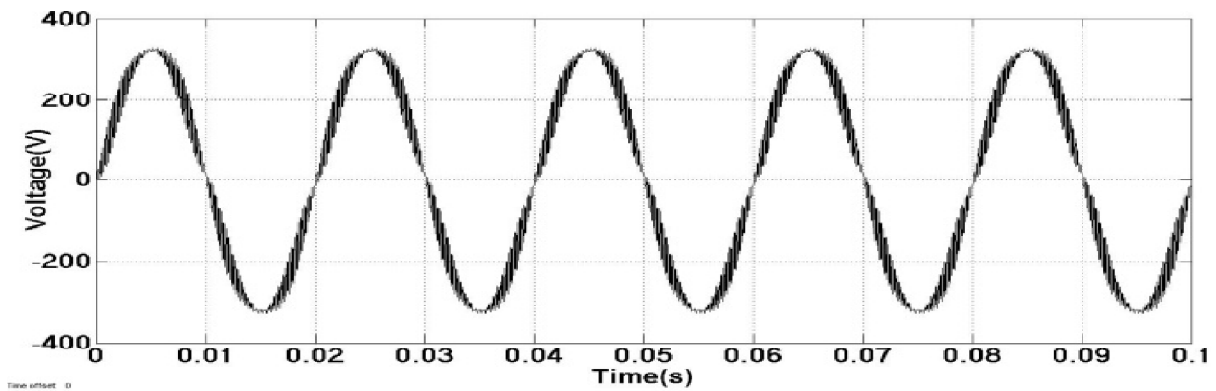

Figure 12: Voltage waveform with LTCL filter for 5 kHz

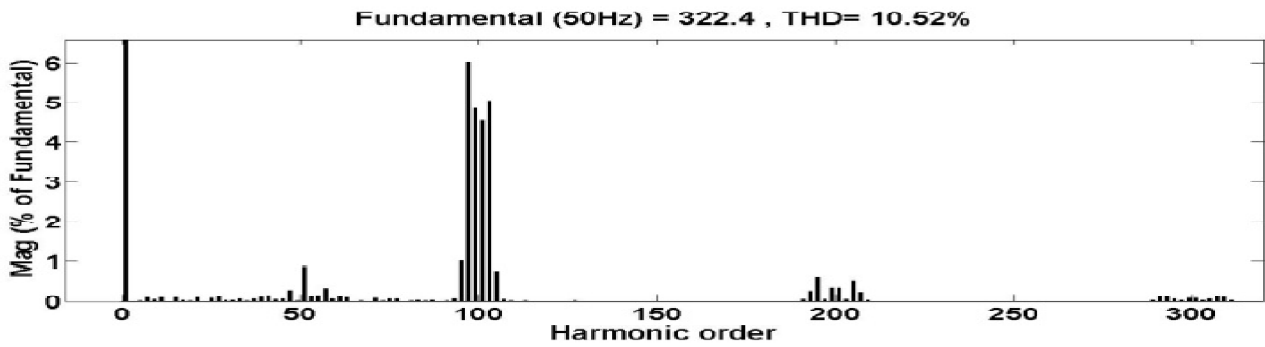

Figure 13: Voltage THD with LTCL filter for 5 kHz

4650 Hz	(h93)	0.06%	-2.4°
4700 Hz	(h94)	0.00%	183.0°
4750 Hz	(h95)	1.01%	-2.1°
4800 Hz	(h96)	0.00%	182.9°
4850 Hz	(h97)	6.03%	-2.1°
4900 Hz	(h98)	0.00%	182.9°
4950 Hz	(h99)	4.86%	-2.2°
5000 Hz	(h100)	0.00%	182.8°
5050 Hz	(h101)	4.57%	177.8°
5100 Hz	(h102)	0.00%	182.8°
5150 Hz	(h103)	5.09%	177.7°
5200 Hz	(h104)	0.00%	182.7°
5250 Hz	(h105)	0.77%	177.5°
5300 Hz	(h106)	0.00%	182.7°
5350 Hz	(h107)	0.05%	176.8°

Figure 14(a): Harmonics around switching frequency with LTCL filter for 5 kHz

9650 Hz	(h193)	0.27%	176.1°
9700 Hz	(h194)	0.00%	182.5°
9750 Hz	(h195)	0.63%	176.1°
9800 Hz	(h196)	0.00%	182.5°
9850 Hz	(h197)	0.05%	176.2°
9900 Hz	(h198)	0.00%	182.5°
9950 Hz	(h199)	0.34%	-4.0°
10000 Hz	(h200)	0.00%	182.5°
10050 Hz	(h201)	0.34%	175.9°
10100 Hz	(h202)	0.00%	182.6°
10150 Hz	(h203)	0.05%	-3.7°
10200 Hz	(h204)	0.00%	182.6°
10250 Hz	(h205)	0.56%	-4.1°
10300 Hz	(h206)	0.00%	182.6°
10350 Hz	(h207)	0.24%	-4.2°
10400 Hz	(h208)	0.00%	182.6°

Figure 14(b): Harmonics around twice switching frequency with LTCL filter for 5 kHz

Results of inverter with LTCL filter for 10 kHz

The inverter output voltage with the LTCL filter for 10 kHz is shown in Fig. 15. The inverter output has got a sinusoidal shape after connecting the filter. The harmonic spectrum is depicted in Fig. 16. The measured THD is 4.31%. The magnitude of harmonics present around 10 kHz and its multiples is as a percentage of fundamental is shown in Fig. 17(a) and Fig. 17(b). It can be seen that the magnitude of harmonics is very much decreased with the LTCL filter.

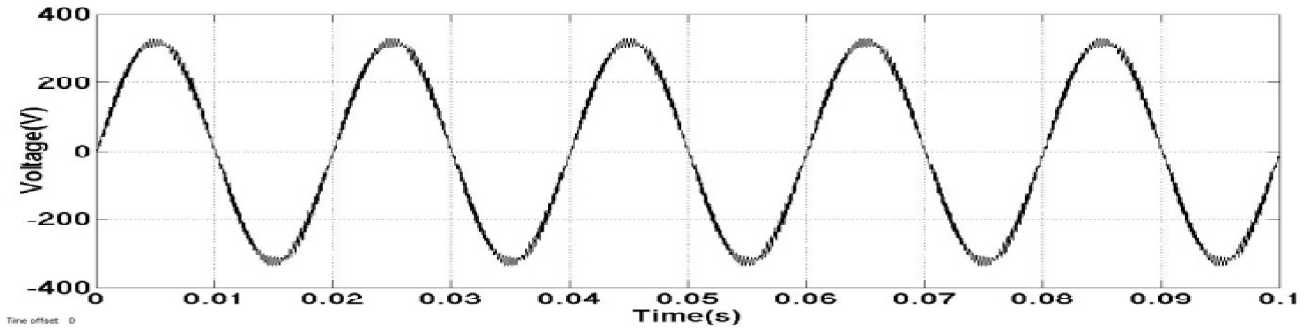

Figure 15: Voltage waveform with LTCL filter for 10 kHz

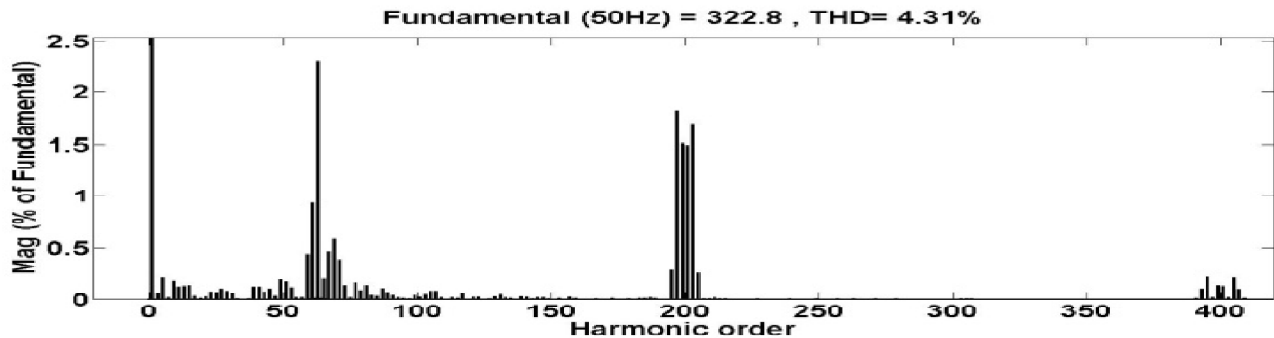

Figure 16: Voltage THD with LTCL filter for 10 kHz

9650 Hz	(h193)	0.00%	185.4°
9700 Hz	(h194)	0.00%	211.0°
9750 Hz	(h195)	0.30%	-3.8°
9800 Hz	(h196)	0.00%	210.8°
9850 Hz	(h197)	1.82%	-3.8°
9900 Hz	(h198)	0.00%	210.6°
9950 Hz	(h199)	1.52%	-3.8°
10000 Hz	(h200)	0.00%	210.3°
10050 Hz	(h201)	1.49%	176.2°
10100 Hz	(h202)	0.00%	210.1°
10150 Hz	(h203)	1.70%	176.1°
10200 Hz	(h204)	0.00%	209.9°
10250 Hz	(h205)	0.27%	176.0°
10300 Hz	(h206)	0.00%	209.7°
10350 Hz	(h207)	0.01%	175.2°

Figure 17(a): Harmonics around switching frequency with LTCL filter for 10kHz

19600 Hz (h392) :	0.00%	198.9°
19650 Hz (h393) :	0.10%	172.8°
19700 Hz (h394) :	0.00%	198.9°
19750 Hz (h395) :	0.23%	172.8°
19800 Hz (h396) :	0.00%	198.8°
19850 Hz (h397) :	0.02%	172.9°
19900 Hz (h398) :	0.00%	198.8°
19950 Hz (h399) :	0.13%	-7.3°
20000 Hz (h400) :	0.00%	198.7°
20050 Hz (h401) :	0.13%	172.6°
20100 Hz (h402) :	0.00%	198.7°
20150 Hz (h403) :	0.02%	-7.2°
20200 Hz (h404) :	0.00%	198.6°
20250 Hz (h405) :	0.22%	-7.4°
20300 Hz (h406) :	0.00%	198.6°
20350 Hz (h407) :	0.09%	-7.5°

Figure 17(b): Harmonics around twice switching frequency with LTCL filter for 10 kHz

From the simulation results and THD analysis, it is found that the SPWM inverter without any filter produces a voltage THD which is very high. The harmonic contents are larger around the switching frequency and around the integral multiples of switching frequency. This creates a large amount of losses in systems wherever it is employed. With the usage of the designed LTCL filter with the same overall inductance value of that of a L filter for 10 kHz, the THD is significantly reduced to 4.31% and the power quality is improved.

5. CONCLUSION

In this paper the performance of a standalone voltage source inverter is analysed with and without filter. The paper concentrates on the design of LTCL filter for the voltage source inverter. The filter design is carried out for different switching frequencies. The harmonic distortion obtained on the inverter output with and without employing filters at various switching frequencies is presented. It is seen that at higher switching frequencies, the filter size is reduced and the THD on the output waveform is less than 5%. The total inductance of a LTCL filter based voltage source inverter is reduced considerably due to its excellent harmonic attenuation capability. The LTCL filter is very flexible as the number of trap branches can be varied according to the application.

REFERENCES

- [1] B.E. Turkay, and A.Y. Telli, "Economic analysis of standalone and grid connected hybrid energy systems," *Renewable Energy*, vol. 36, no. 7, pp. 1931-1943, Jul. 2011.
- [2] B. Yang, L. Wi, Y. Zhao, and X. He, "Design and analysis of a grid-connected photovoltaic power system," *IEEE Transactions on Industrial Electronics*, vol. 25, no. 4, pp. 992-1000, Apr. 2010.
- [3] S. Jain, and V. Agarwal, "A single-stage grid connected inverter topology for solar PV systems with maximum power point tracking", *IEEE Transactions on Power Electronics*, vol. 22, no. 5, pp.1928-1940, Sep. 2007.
- [4] M. Calais, J. Myrzik, T. Spooner, and V.G. Agelidis, "Inverters for single-phase grid connected photovoltaic systems - an overview", in *Proc. IEEE Power Electronics Specialists Conference*, vol. 4, pp. 1995-2000, Jun. 2002.
- [5] R.J. Wai, and W.H. Wang, "Grid-connected photovoltaic generation system," *IEEE Transactions on Circuits and Systems 1: Regular papers*, vol. 55, no. 3, pp. 953-964, Apr. 2008.
- [6] M. Azri, and N.A. Rahim, "Design analysis of low-pass passive filter in single-phase grid-connected transformerless inverter", in *Proc. 2011 IEEE First Conference on Clean Energy and Technology*, pp. 348-353, Jun. 2011.

- [7] H. Cha, and T.K. Vu, “Comparative analysis of low-pass output filter for single-phase grid-connected photovoltaic inverter”, in Proc. IEEE. Applied Power Electronics Conference and Exposition, pp. 1659–1665, Feb. 2010.
- [8] P. Channegowda and V. John, “Filter optimization for grid interactive voltage source inverters,” IEEE Transactions on Industrial Electronics, vol. 57, no. 12, pp. 4106–4114, Dec. 2010.
- [9] M. Jayaraman, V.T. Sreedevi, and R. Balakrishnan, “Analysis and Design of Passive Filters for Power Quality Improvement in Standalone PV Systems,” in Proc. 2013 Nirma University International Conference on Engineering, Nov. 2013, pp. 1-6.
- [10] S.N.A.L. Yousif, M.Z.C. Wanik, and A. Mohamed, “Implementation of different passive filter designs for harmonic mitigation”, in Proc. National Power and Energy Conference, pp. 229–234, Nov. 2004.
- [11] M.T. Bina, and E. Pashajavid, “An efficient procedure to design passive LCL-filters for active power filters”, Electric Power Systems Research, vol. 79, no. 4, pp. 606–614, April 2009.
- [12] W. Wu, Y. He, and F. Blaabjerg, “An LLCL power filter for single-phase grid-tied inverter,” IEEE Transactions on Power Electronics, vol. 27, no. 2, pp. 782–789, Feb. 2012.
- [13] W. Wu, Y. He, T. Tang, and F. Blaabjerg, “A new design method for the passive damped LCL and LLCL filter-based single-phase grid-tied inverter,” IEEE Transactions on Industrial Electronics., vol. 60, no. 10, pp. 4339–4350, Oct. 2013.
- [14] T. Liu, X. Hao, X. Yang, M. Zhao, and L. Xiong, “A novel grid voltage feed forward control strategy for three-phase grid-connected VSI with LCCL filter,” in Proc. 2012 IEEE International Symposium on Industrial Electronics, May 2012, pp. 86–91.
- [15] J. Xu, J. Yang, J. Ye, Z. Zhang and A. Shen, “An LTCL filter for three-phase grid-connected converters,” IEEE Transactions on Power Electronics, vol. 29, no. 8, pp. 4322-4338, Aug. 2014.
- [16] T.C. Wang, Z. Ye, G. Sinha and X. Yuan, “Output filter design for grid-interconnected three-phase inverter,” in Proc. IEEE 34th Annual Power Electronics Specialists Conference, Jun. 2003, vol. 2, pp. 779–784.
- [17] X. Zheng, L. Xiao, Y. Lei, and Z. Wang, “Optimisation of lcl filter based on closed-loop total harmonic distortion calculation model of the grid-connected inverter,” IET Power Electronics, vol. 8, , no. 6, pp. 860–868, Jun. 2015.