



International Journal of Control Theory and Applications

ISSN : 0974-5572

© International Science Press

Volume 9 • Number 47 • 2016

Design of a New Dual Band Defected Ground Microstrip Patch Antenna for WLAN/WiMax and Satellite Application

¹E. Sarva Rameswarudu and ²P. V. Sridevi

¹Assistant Professor in Department of ECC in Kakinada Institute of Technology and Science, Divili, AP, India

¹Research Scholar, Department of ECE, Andhra University, AP, India

²Professor, Department of ECE, Andhra University, AP, India

Abstract: In this paper, a microstrip patch antenna combined with a new spiral shape defected ground structure is investigated. The proposed antenna has a new spiral shape and is placed in the ground plane of a patch antenna. The proposed antenna designed at 2.4GHz and the simulation is accomplished by HFSS software and measured returnloss, radiation pattern, gain and efficiency at two dual frequencies 2.76GHz and 3.27GHz. The results are improved for defected ground structures patch antenna compared with basic rectangular patch antenna.

Keyword: Microstrip patch antenna, Defected Ground Structures, HFSS.

I. INTRODUCTION

In the modern days communication is amazingly transformed from wire to wireless. Wireless communication provides inexpensive and flexible way for communication [1]. Antenna is one of the important elements of the wireless communications systems. One of the antenna elements is microstrip patch antenna for wireless communication. Microstrip patch antenna is the planar type antenna which provides more advantages such as low profile, inexpensive, lightweight, low volume compatibility with integrated circuits and they can easily be fabricated to operate dual band and multiband applications. Patch antennas constitutionally have narrow bandwidth and to enhance the bandwidth, many techniques are developed.

One of the techniques in recent approaches is Defected Ground Structures (DGS) to improve circuit performance and more investigation [2-3] is being carried out. Defected ground structure method is used to reduce the size of the antenna for particular frequency compared to the without defected ground structure patch antenna. By introducing defected shape on the ground plane [4-5] will disturb the shielded current distribution based on the shape of the defect which will influence the current propagation [6-7] through antenna and input impedance. This can also control the excitation, harmonics and electromagnetic waves propagating through the substrate layer.

In this paper a new spiral shaped DMS (SDMS) is introduced [8-10] to obtain the dual frequencies and miniaturized size compared with the conventional microstrip patch antenna. The SDMS and without SDMS is simulated at the same dimensions to verify the antenna parameters.

II. SPIRAL-SHAPED DEFECTED MICROSTRIP STRUCTURE

The Layout of the proposed SDMS top view, bottom view and conventional microstrip patch antenna as shown in Figure1. The Fig 1a represents the conventional rectangular microstrip patch antenna designed for single band frequency using the equations [1] of rectangular microstrip patch antenna and then modified with defected ground structures to achieve the dual band frequencies.

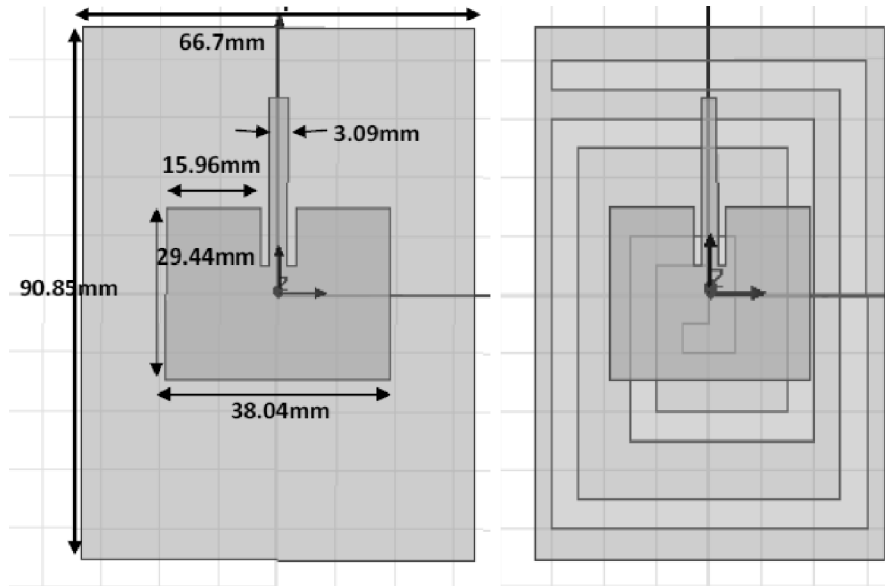

Figure 1a: Conventional MPA

Figure 1b: Top view of SDMS

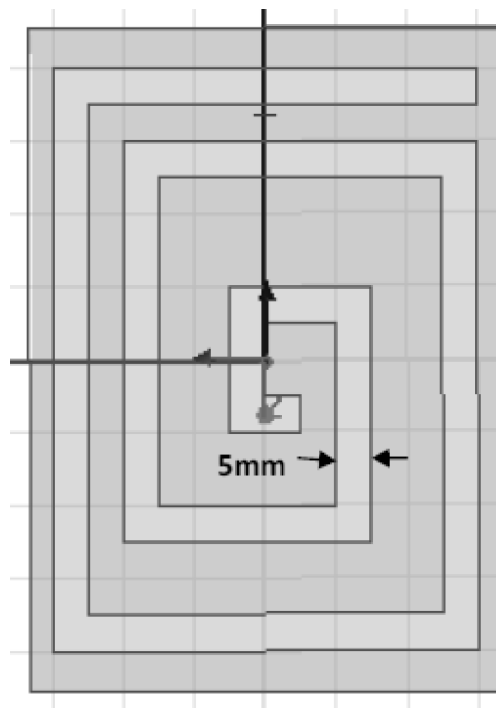

Figure 1c: Bottom view of SDMS

(A) Single band microstrip patch antenna

The dimensions of the single band microstrip patch antenna are shown in Fig. 1a. The substrate used for microstrip patch antenna is Glass epoxy with height 1.6mm, dielectric constant $\epsilon_r = 4.4$ and loss tangent = 0.0009. The geometry and parameters of the microstrip patch antenna can be calculated as follows for the central frequency (f_r) of 2.4GHz. The width (W) of the patch antenna is calculated by

$$W = \frac{c}{2ff_r} \sqrt{\frac{2}{\epsilon_r + 1}}$$

Where c is the free space velocity of light. The actual physical length (L) of the patch antenna is calculated by $L = L_{\text{eff}} - 2\Delta L$, where L_{eff} is the effective length of patch antenna caused by fringing fields and ΔL is the extended length due to fringing fields. L_{eff} and ΔL are given by

$$L_{\text{eff}} = \frac{c}{2f_r \sqrt{\epsilon_{\text{reff}}}}$$

$$\Delta L = 0.412h \frac{(\epsilon_{\text{reff}} + 3) \left(\frac{W}{h} + 0.264 \right)}{(\epsilon_{\text{reff}} - 0.258) \left(\frac{W}{h} + 0.8 \right)}$$

Where ϵ_{reff} is the effective dielectric constant of microstrip patch antennas on dielectric substrate

$$\epsilon_{\text{reff}} = \frac{\epsilon_r + 1}{2} + \frac{\epsilon_r - 1}{2} (1 + 12h/W)^{-1/2}$$

1. Length of patch (L) 29.44 mm,
2. Width of patch (W) 38.04 mm,
3. Width of microstrip feed line (W_0) 3.09 mm,
4. Inset feed distance (IFD) 28.54 mm,
5. Inset feed gap (IFG) 1.529 mm

(B) Dual band microstrip patch antenna

Dual band microstrip patches antenna geometrical representation as shown in Fig. 1b. and 1c represent top view and bottom view respectively. The etching of slots creates defect in the ground plane of the radiating patch which disturbs the shield current distribution in the ground plane. This disturbance affects the input impedance and increases the effective inductance and capacitance of the transmission line. The etching of slots from the ground plane enhances the bandwidth. The etching of slots leads to many parameters to be examined for dual-band operation.

III. SIMULATION RESULTS

(A) Single band Antenna

Fig 2.a. shows the single band without SDMS antenna return loss is -12.86 dB at 2.4GHz which define good matching between the antenna and feedline. The band width at -10dB is equal to 23.3MHz at the center frequency of 2.394GHz (0.97% of the center frequency). Fig 2.b. represent the 2-D radiation pattern for E-Plane ($\Phi = 0^\circ$) and H-Plane ($\Phi = 90^\circ$) in a rectangular

Plot. The maximum gain of the single-band patch antenna is 6.5 dB at $\Theta = 0^\circ$ and 94.7% efficiency.

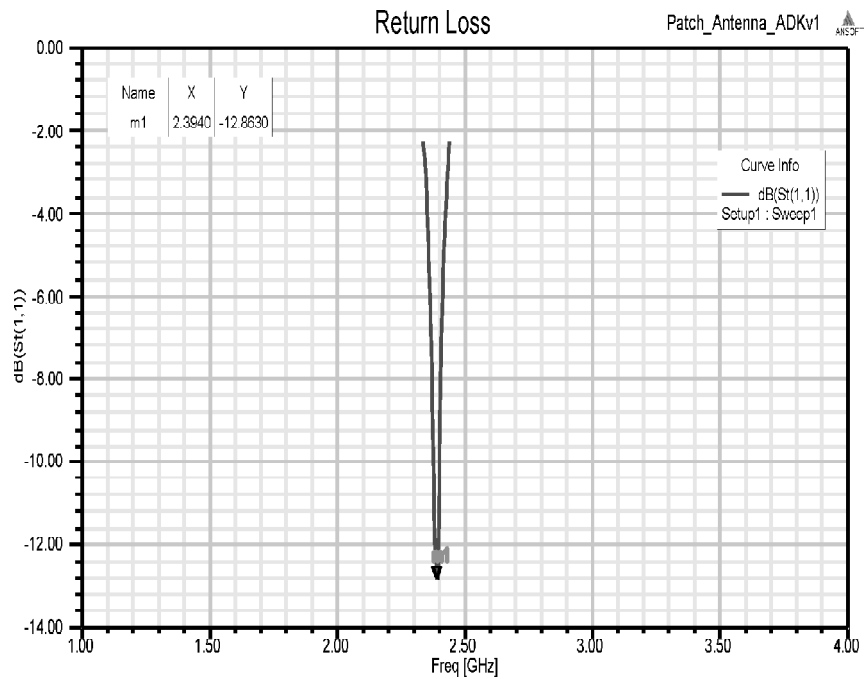

Figure 2a: Returnloss curve at 2.4GHz

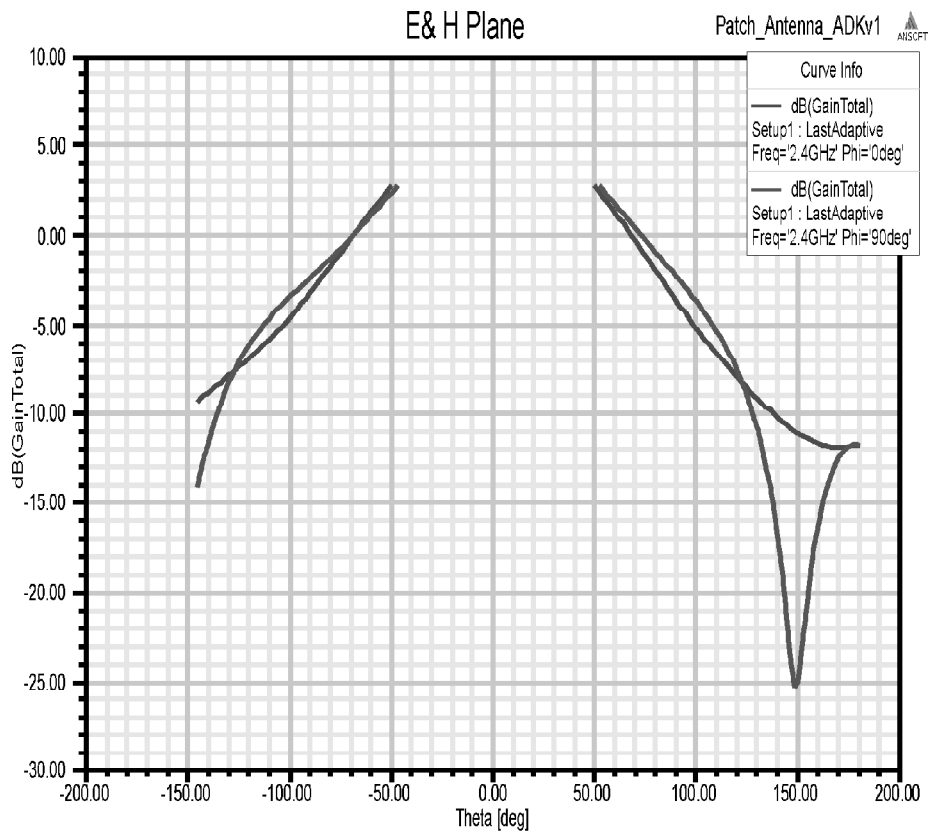

Figure 2b: Rectangular plot of gains in E-Plane ($\Phi = 0^\circ$) and H-Plane ($\Phi = 90^\circ$), for the single-band Microstrip patch antenna for 2.4GHz

(B) Dual band Antenna

Fig 3. shows the dual band with SDMS antenna return loss is -28.58 dB at 2.76GHz and -24.98 at 3.27 GHz. The band width at -10dB is equal to 118.5MHz at the center frequency of 2.76GHz (4.29% of the center frequency) and 137.8MHz at the center frequency of 3.27GHz(4.21% of the center frequency) and efficiency at 3.27GHz is 98.9% and 99.29% at 2.76GHz.

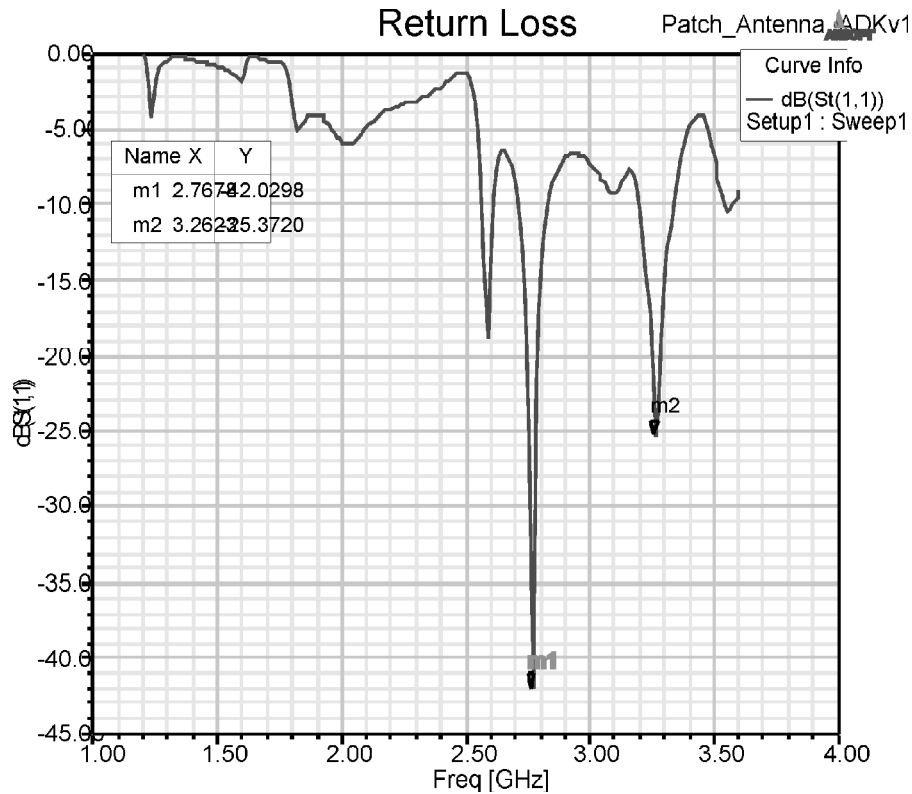

Figure 3: Return loss curve of SDMS

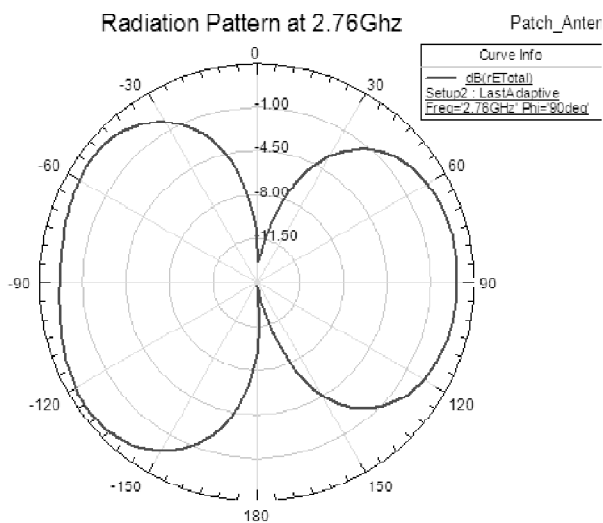

Figure 4a: H Plane Radiation pattern at 2.76GHz

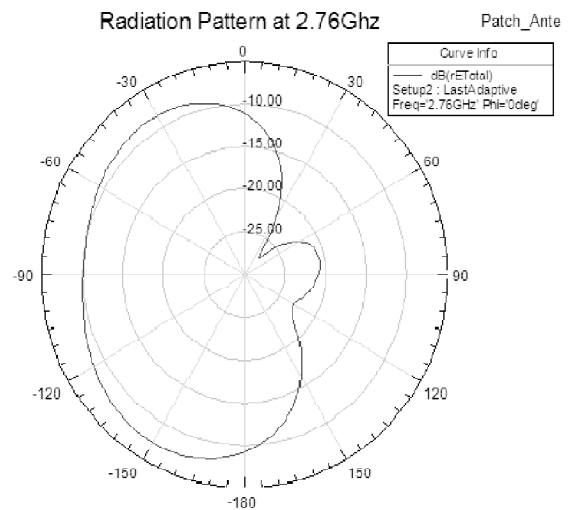

Figure 4b: E Plane Radiation pattern at 2.76GHz

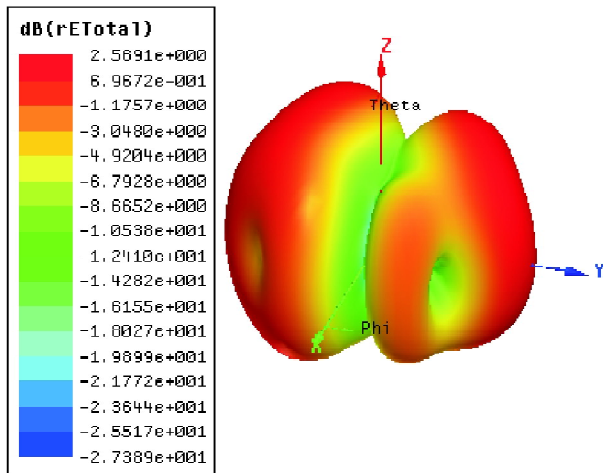

Figure 5a: H Plane Radiation pattern at 2.76GHz

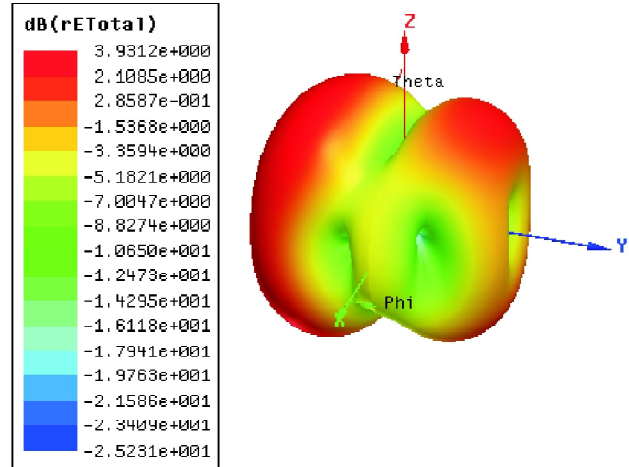

Figure 5b: E Plane Radiation pattern at 3.26GHz

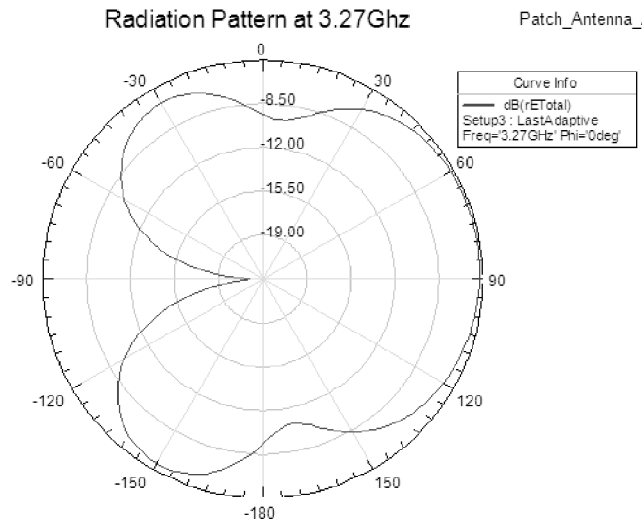

Figure 6a: E Plane Radiation pattern at 3.26GHz

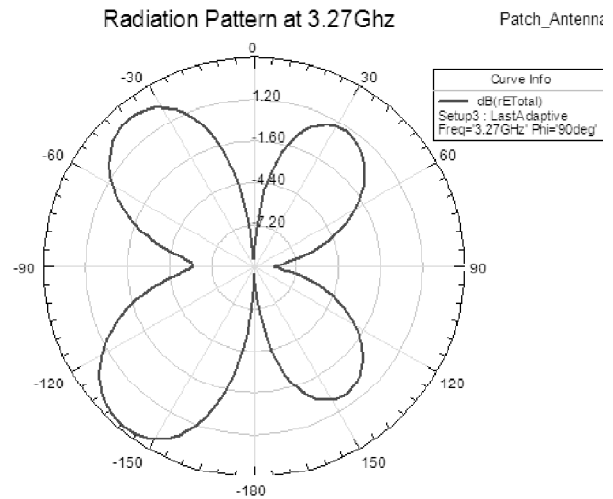

Figure 6b: H Plane Radiation pattern at 3.26GHz

Fig. 4a and Fig 4b shows E-Plane ($\Phi = 0^\circ$) and H-Plane ($\Phi = 90^\circ$) polar plot radiation pattern of SDMS antenna at 2.76GHz resonant frequency, Fig 6a and Fig 6b shows E-Plane ($\Phi = 0^\circ$) and H-Plane ($\Phi = 90^\circ$) polar plot radiation pattern of SDMS antenna at 3.26 GHz resonant frequency and Fig 5a and Fig 5b shows 3D polar plot radiation pattern of Spiral shape Defected ground Microstrip (SDMS) antenna at 2.76GHz and 3.26GHz.

IV. CONCLUSION

A Spiral shape Defected ground Microstrip (SDMS) antenna has been designed at dual band for 2.76GHz and 3.26GHz wireless communication in C band Applications. By etching of slots from the Ground plane in spiral shape to gain dual band. The proposed antenna achieves dual-band operation with large useful bandwidths at -10dB is equal to 118.5MHz at the center frequency of 2.76GHz (4.29% of the center frequency) and 137.8MHz at the center frequency of 3.27GHz(4.21% of the center frequency) and efficiency at 3.27GHz is 98.9% and 99.29% at 2.76GHz(13.56% at 2.5 GHz and 10.36% at 3.5 GHz), as well as the efficiency of the proposed antenna is higher than that of previously reported antenna using the without defected ground plane technique.

ACKNOWLEDGEMENT

Authors like to express their gratitude towards the department of ECE, Andhra University and Management of Kakinada Institute of Technology and Science for their support and encouragement during this work.

REFERENCES

- [1] Imad Ali and Ronald Y. Chang, "Design of Dual-Band Microstrip Patch Antenna with Defected Ground Plane for Modern Wireless Applications.
- [2] J. Ghalibafan and A. R. Attari, F. H. Kashani" A NEW DUAL-BAND MICROSTRIP ANTENNA WITH U-SHAPED SLOT", Progress In Electromagnetic Research C, Vol. 12, 215{223,2010.
- [3] G.-L. Wu, W. Mu, X.-W. Dai, and Y.-C. Jiao," DESIGN OF NOVEL DUAL-BAND BANDPASS FILTER WITH MICROSTRIP MEANDER-LOOP RESONATOR AND CSRR DGS" Progress In Electromagnetic Research, PIER 78, 17–24, and 2008.
- [4] S. Maci and G. Bifji Gentili, "Dual-Frequency Patch Antennas", IEEE Antennas and Propagation Magazine, Vol. 39, No. 6, December 1997.
- [5] Young Ju Lee, *Student Member, IEEE*, Junho Yeo, *Member, IEEE*, Raj Mittra, *Life Fellow, IEEE*, and Wee Sang Park, *Member, IEEE*, " Application of Electromagnetic Band gap (EBG) Superstrates With Controllable Defects for a Class of Patch Antennas as Spatial Angular Filters", IEEE TRANSACTIONS ON ANTENNAS AND PROPAGATION, VOL. 53, NO. 1, JANUARY 2005.
- [6] M. Abdollahvand, G. Dadashzadeh, and D. Mostafa," Compact Dual Band-Notched Printed Monopole Antenna for UWB Application", IEEE ANTENNAS AND WIRELESS PROPAGATION LETTERS, VOL. 9, 2010.
- [7] Juhong Shen, Chunlan Lu, Jiale Zhang," Heart-Shaped Dual Band-Notched UWB Antenna", 2014 3rd Asia-Pacific Conference on Antennas and Propagation.
- [8] Chang won Jung and Franco De Flaviis,"A Dual-Band Antenna for WLAN Applications by Double Rectangular Patch with 4-Bridges"
- [9] Debatosh Guha, Sujoy Biswas), and Chandrakanta Kumar," Printed Antenna Designs Using Defected Ground Structures: A Review of Fundamentals and State-of-the-Art Developments", Forum for Electromagnetic Research Methods and Application Technologies (FERMAT).
- [10] Ling-Feng Mao," A Compact Narrow-Band Bandstop Filter Using Spiral-Shaped Defected Microstrip Structure", RADIOENGINEERING · APRIL 2014.