



International Journal of Control Theory and Applications

ISSN : 0974-5572

© International Science Press

Volume 10 • Number 35 • 2017

A Low-Cost Warehouse Inventory Management System using Internet of Things and Open source Hardware

B. Sai Subrahmanya Tejesh^a and K. Sripath Roy^b

^aCorresponding author, Department of ECSE, K.L. University, Green Fields, Guntur DT, AP, 522502, India. Emails: tejeshbss@gmail.com;

^bDepartment of ECE, K.L. University, Green Fields, Guntur DT, AP, 522502, India. Emails: koganti_sripathroy@kluniversity.in

Abstract: The smart systems are playing dominant aspects in the present real world scenarios. In general, warehouses are used to store goods or products. In the Warehouses, if the user wants to locate any product it is very difficult, because user have to do a detailed search manually in all the available stockrooms this requires a lot of effort. So to avoid this problem the warehouse inventory management system is very helpful because it maintains the detailed product information and tells us in which stockroom the product is present. The warehouse inventory management system is playing a significant aspect in many productions and goods based methodology. Though there are many wireless communication technologies the RFID suits the best for the warehouse inventory management system. The tag information is transferred from the transmitter section to open source hardware via a wireless link with the aid of internet. The warehouse inventory management system built on the architecture of the Internet of Things is developed to track the products attached to the tags with product information and their respective time stamps for further verification. The Raspberry Pi acts as a central server, monitoring all the information. The total system gives an archetype to correspond the information flow and material flow. The web page which is built in accordance to provide convenient and an interface to the user to track the products. The developed system results a very low cost system and works dynamically compared with the existing present warehouse inventory management systems.

Keywords: IoT, RFID, Warehouse inventory management system, Wi-Fi module, Open source hardware.

1. INTRODUCTION

Smart systems are playing a major role in industries, home, colleges, and other native environments. In the smart systems, there is a linear growth in the localization concept, because localization is playing a crucial role in contemporary life [1]. It is really challenging to locate any particular object accurately. Localization can be done in two ways Type-1 and Type-2 [2]. IoT is a vision that permits individuals and things to be associated in a perfect world utilizing any path or any service [3]. The need or urge for this warehouse inventory management system, it is very challenging to track, identify products or objects in big industries. To track any product in a precise span of time it is very difficult.

The section where goods or products are stored is called the Warehouse. The prime goal of the Warehouse is to control the flow of products or items. The products must be managed cautiously otherwise it may affect on time, cost [4]. In the globalization of industries, the warehouse inventory management system has its own significance because of the profits it is persuading. Warehousing cites to the activities engaging in the storage of products on a huge scale in a precise way and accomplishing their availability whenever required. The need for a warehouse to store different types of products or goods to maintain seasonal production, seasonal demand, quick supply, continuous production, price stabilization [5]. The warehouse inventory management system is a requisite approach for every warehouse. A computerized warehousing system provides us less effort, more efficient and stable results are correlated with hand held manual system. In Warehouse there may be many zones, those zones are also called as Stockrooms. Depending upon the demand of the products, more products have to be stored. So Warehouse requires more number of stockrooms. The urge for automating the warehouses originates from the fact that manual handling systems may lead to human errors which may affect the warehouse utilization..

Identification mechanism relies on AIDC (Automatic identification and data capture) technology. The traditional AIDC technology is Barcode technology, which is operated by optical scanners to read labels. Barcodes are an immense advancement made over normal text labels because the staff is no longer essential to manually enter data into the system. The RFID technology replaces the Barcode technology because barcode scanners are high in cost, security is less. If the label damages the scanner cannot read the data [6]. The RFID tags have more data capacity storage than Barcode. Based on many researches, The RFID technology sustain to be significant and efficient in identification system. RFID technology created an impact in the domain of Warehouses because it eliminates the risks in industries, efficiency is improved, products can be tracked easily, with the involvement of Electronic product code theft problems are also eliminated [7].

Internet of Things can be easily employed with RFID, the transfer of signals is based on radio communication. To reduce the interference by many radio waves, the appropriate RFID system design must be chosen. IoT nodes are ascendable. The network becomes more sophisticated as the node rapidly rises [8]. The association of physical and virtual objects through the process of data acquisition and communication competence. IoT facilitates sensor connection capability for the expansion of independent services and applications [9]. IoT is classified into three layers they are the perception layer or context-aware, network layer, Service layer [10]. In the perception layer, the data from the physical world are perceived and congregated with the usage of WSN, Sensors, RFID system. In the network layer, it enables transparent data transmission competence. It facilitates efficient, reliable transmission to the upper layer. The GSM, WSN, GPRS, Ethernet conveys the data from the perception layer to the upper layer. In the service layer, it includes data management sublayer and application sublayer. The data management sublayer contributes to process complex data. The application sublayer facilitates the user with a good user interface for application such as logistics, agricultural management, product management. The Application Sublayer The routing of data must be done conveniently so that data must be transferred from source to destination. Localization, tracking, positioning are some of the main applications for the RFID and IoT. Figure 1 brief's out the various emerging applications in the scope of IoT. The Warehouse inventory management system facilitates the user with the flow of products. So this system can be needed wherever identification of location is needed.

2. RELATED WORK

There are many challenging aspects that warehouse inventory management system must consider because in the Real world the indoor native habitats are confined by the dimensions of the zone. Accuracy illustrates what is the fluctuation from the predicted location to the actual or original location. Thus the accuracy of the system should be high, within a precise scope. The product tracking system is built accordingly, it must work

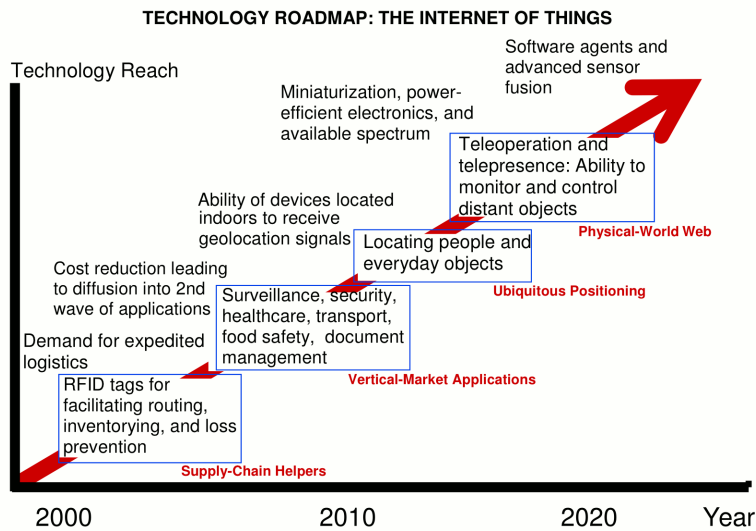

Figure 1: Technology Roadmap for Internet of Things

accurately even without direct line of sight. The cost always needs to be taken care, because implementing the system for extensive consumer applications must not result in high cost. In Real time, the system must deal with the tracking number of products so cost must be stabilized. Flexibility is an important challenge because the developed system will be given to distinct tracking items with a slight alteration. The system should contribute its services to users, but must not disrupt their everyday lives [10]. The system must be handy and very comfortable for the user to use it, but many existing systems present the positioning result based on the coordinates of the tracked product [11].

The objects can be identified in both indoor and outdoor environments, the few following technologies that can be adopted are discussed below. Coming to the point of outdoor environments the GPS (Global positioning system) is well suited for tracking the objects, but the GPS system is not suited for tracking or locating the products in the Warehouse environments because of its decreased accuracy and poor reception of satellite signals in the indoor environments [12]. The object that to be tracked is constructed on a virtual map based on the latitudes and longitude position. GPS performance diminishes if assured signal strength is unbiased with the system being deployed. The Inertia navigation system (INS) is utilized for locating and tracking of objects, but this system is applicable only in outdoor environments [13] - [14]. Sensors are the devices that detect a signal and tell the system about the received signal. The INS system is restricted because of their high cost, the system is unreliable and has lower working range. The Bluetooth has a variable read range and it is capable of ranging in terms of 1m/10m/50m. The cost of the Bluetooth system hikes if more range is required. The main drawback of the Bluetooth system is it has confined number of 7 slaves [13] - [15].

The Infrared system has an efficiency range of 5-10 meters. The infrared system is low-priced, compact, low power consumption. In Real-time warehouse working scenarios they are susceptible to light sources and also require an acceptable line of sight for the devices to get communicated. The fundamental of infrared positioning is that the IR modulated infrared beam of light is analyzed by applying the optical transducer hooked up to the indoor positioning receiver. In the Ultrasonic system, the distance of the object to be tracked is calculated by using the echoes. The cost of this system implementation is very high because the Ultrasonic transceivers must be installed throughout the surroundings. This system may cause health effects, both the transmitter and receiver section must have a line of sight, it requires a huge setup and maintenance of the system is very challenging. The GNSS can be working for both outdoor and indoor environments. It is also similar to Global positioning

system as the signals get degraded, to overcome this problem, it is recommended to use High resistive GNSS [13] - [15]. The active bat is a different Ultrasonic positioning system, they require active bat tags that are mobile which transmit an ultrasonic pulse to fixed ultrasonic receivers mounted on the ceiling. This system has health effects, and the maintenance of the system is very high. The locato system is a radio based positioning system, mostly suitable where enough satellite signals are received. This system has a transceiver unit called localatile and standalone receiver called as locato. To form a network, the system requires a minimum of four localities. The drawback of this system is it has low elevation angles and interference of different signals in the atmospheric layer.

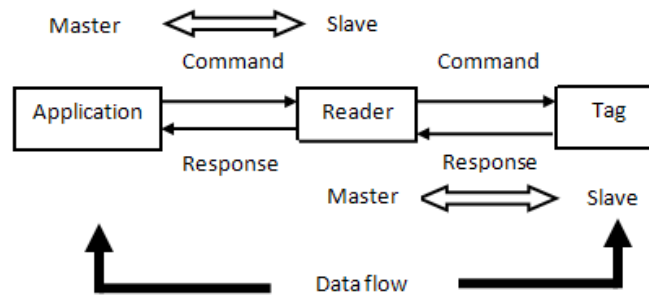

Figure 2: The Components of RFID System

RFID stands for Radio Frequency Identification. Among the wireless communication technologies like Bluetooth, infrared, ultrasonic, video camera, RFID. The RFID suits to be the best because it is low cost, robust can be easily integrated into any field of application [16]. The Figure 2 serves as the representation of any basic RFID system. The RFID works on the revelation of EM signals. The RFID system consists of a tag and reader, depending on our application the selection of tags can be made. RFID technology is established on the perception of magnetic coupling, the assumption is that current flowing in one circuit can generate a current flow in another circuit via a magnetic field developed in the slot between the circuits [17]. The RFID tags can be easily identified based on the unique identification number by the RFID reader, that is why the RFID is majorly used in the identification and tracking scheme [18]. The RFID tags are mainly portioned into three sections they are active tags, passive tags and semi-passive tags [19]. Among all the above-mentioned tags, the passive tags play a vital role in many applications because of its low size, low power consumption, low cost, no interference problem, it can work in harsh environments [20]. The circuit in the passive tag is precisely powered by the carrier signal from the reader. The passive tags get activated when they pass through the electromagnetic zone. The Active and Semi-passive tags contain their own battery and they are larger in size and are difficult to handle. Depending on the type and need the tags are applied in a specific application [21]. Though there are many applications for RFID, applying RFID for the warehouse inventory tracking best suits for the application [22]. The RFID has various applications such as location identification of people, medical assets in trauma centers, distinguishing between products in warehouses based upon the tags adhered to them [23] - [24]. Hence the RFID technology suits best for tracking and positioning objects uniquely.

3. HARDWARE MODULES USED FOR THE SYSTEM IMPLEMENTATION

Figure 3 represents the block diagram of the implemented system and the elaborated description of the modules used are discussed below.

RFID System: The Warehouse inventory management system is one of the application of RFID technology, because RFID can uniquely identify products or goods attached with tags. The RFID reader em-18 used to read 125 kHz tags. The RFID reader operates at a voltage of 5 V. The Reader has two fundamental objectives: initially reader to transmit a carrier signal, and the subsequent is to receive a response from any tags in the proximity

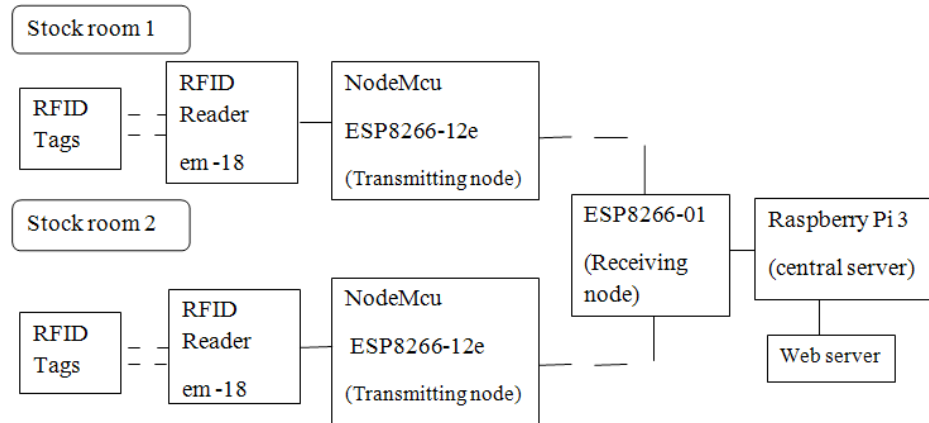

Figure 3: Block diagram of the experimental setup

of the reader. The RFID reader emits a short range radio signal which is picked by a RFID tag and the tag is triggered on. The two RFID readers em-18 is attached at the beginning of the stockroom 1 and stockroom 2 to read the tags. The RFID em-18 works on UART. The em-18 RFID reader is interfaced to NodeMcu ESP8266 and is programmed by using Arduino IDE. The passive tags are adhered to the products or goods to uniquely identify them. As soon as the RFID reader scans the tag, then the tag transmits back a short string of data. The passive tags 125 kHz are more beneficiary over active and semi-passive tags because of its low cost, low power consumption, no interference effect. The unique ID of the tag contains 12 bytes of data 0D0021A8D256. The last two digits indicate the checksum which is the result of XOR operation of first ten bytes. The data scanned by the reader is used to decode the encoded data in the tag's IC and the data is sent to the Raspberry Pi 3 central server via NodeMcu ESP8266.

ESP8266-01 Wi-Fi module: The ESP8266-01 is a serial device, a low-cost module with full stacks TCP/UDP it gives any microcontroller the Wi-Fi facility. The Esp8266-01 Wi-Fi module is interfaced with Raspberry Pi 3. All the Esp8266 are connected to common Wi-Fi Access point and data is transferred within them with the support of internet. Suppose the data collected from RFID reader attached at stockroom 2 is collected by NodeMcu and with the help of Wi-Fi module Esp8266-12e present in it, from the transmitter section the data is sent to the Esp8266-01 that is attached to the receiving section of the Raspberry Pi 3 and hence the data is arranged in tables in the web server.

NodeMcu ESP8266-12e Wi-Fi development board: NodeMcu is an open source IOT platform with a deployed ESP8266-12e Wi-Fi module in it. It supports USB micro port for programming the NodeMcu. The em-18 module is interfaced with the NodeMcu ESP8266, the data from the em-18 RFID reader is sent to the NodeMcu. It works on an operating voltage of 5V, but the ESP8266-12e module requires 3.3V for that purpose all the required circuitry for the voltage conversion are held in the NodeMcu board. The NodeMcu can be programmed with the Arduino IDE and the AT commands can be easily integrated which makes coding simpler. The NodeMcu can be programmed in two modes that is STA mode, AP mode. For simplicity, the Nodemcu is programmed in the STA mode.

Raspberry Pi 3: Here at this Warehouse inventory management System, the Raspberry Pi 3 plays a vital role because it is the main agent which maintains all the products or goods details in the database. The data from stockrooms is received in the Raspberry Pi 3 with the help of ESP8266 attached to it. The user in the search field types the tag number and the tag number is queried from the database. The Raspberry Pi 3 here also acts as a web server. The Raspberry Pi 3 is programmed with the Python language. The Raspberry Pi 3 functions at 5V. Raspbian is the Linux-based operating system which is running on Raspberry Pi 3.

4. SYSTEM IMPLEMENTATION METHODOLOGY

The implemented methodology is for efficient production and goods identification in warehouses. The fundamental need for the warehouse is to store different types of products. The developed system is used efficiently to monitor the mobility and storage of products. Among the various mentioned positioning technologies RFID technology seems to be the most desirable candidate for tracking because of its low cost, robustness, flexibility. RFID can successfully integrate with the Internet of Things. Figure 4 exhibits the transmitter node and Figure 5 exhibits the receiver node. Hence Figure 4 and Figure 5 depicts the hardware experimental setup of the implemented System.

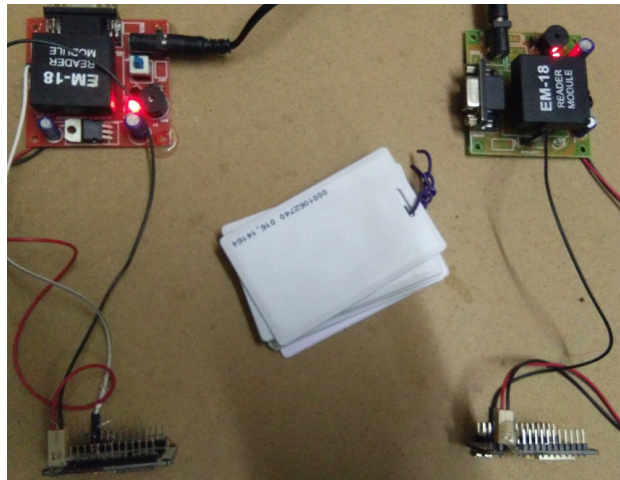

Figure 4: Transmitting nodes of Stockroom 1 and Stockroom 2

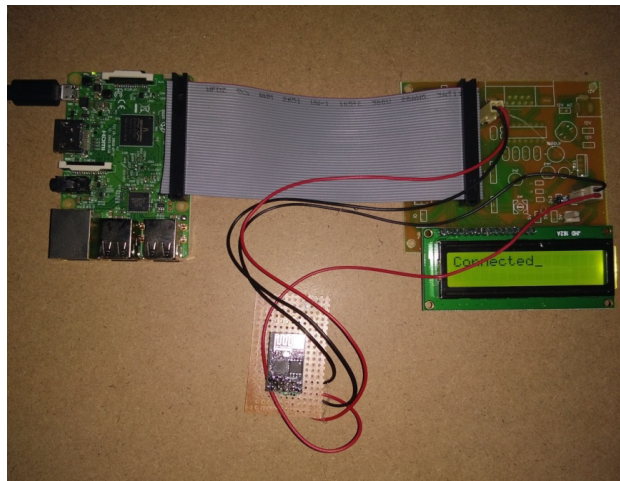

Figure 5: Receiving node of the Implemented system

Here in the implementation of the Warehouse inventory management system, It comprises of two stockrooms that are stockroom 1 and stockroom 2. To demonstrate the system, there is a need for two transmitter sections and one receiver section which acts as a central server. Each RFID tag has a unique, Identification number, RFID reader has an address. The passive tags are preferred because they are having less interference effect, maintenance cost is less and flexible because it can adhere to any physical object in the real world. In this system, passive tags have adhered to the products or goods. The two transmitter section's used here resembles stockroom 1 and stockroom 2. The two transmitter sections are built using RFID reader em-18, NodeMcu ESP8266 Wi-Fi development module. Every transmitter section has its own RFID Reader em-18 and NodeMcu ESP8266-12e.

The data from the transmitter section's that is from stockroom 1 and stockroom 2 are sent to the Raspberry Pi 3 which is acting as a central server via a wireless link with the help of ESP8266-01 a very low-cost Wi-Fi module. Every stockroom will be arranged with the discussed experimental setup. As soon as the RFID reader em-18 scans the passive RFID tags that are in its range, with the help of NodeMcu ESP8266-12e Wi-Fi development module the tag details are collected and as the NodeMcu is programmed in the Station mode so that the NodeMcu ESP8266-12e module can connect to any local/home Wi-Fi. The NodeMcu ESP8266 has a deployed ESP8266-12e module in it. In the central server receiver section, the system is developed using ESP8266-01 Wi-Fi module and Raspberry Pi 3. The ESP8266-12e module on NodeMcu and the ESP8266-01 interfaced with Raspberry Pi 3, all the ESP8266 modules connect to common Wi-Fi access point to communicate the data between them. The data from the stockrooms is gathered in the Raspberry Pi 3 with the help of an ESP8266-01 Wi-Fi module.

The Raspberry Pi 3 is programmed in such a manner so that the accumulated information is set in the format of rows and columns are displayed to the User person with the aid of the user-friendly web pages. In the web server first, the central person must authorize to enter into the web page. On the web page, the details like tag number, product description, stockroom number, location, Time details are stored in the database and displayed to the user in the table format. So if the user wants to know in which stockroom the specified product is there, the user gently types the product tag number and the detailed information is fetched from the database and displayed in the web page with the help of user interface.

Suppose if the user wants to search a tag number 0D0021A8D256, the user gently types the tag number in the search field all the required information regarding the product and the product time stamps that is attached to the tag are displayed in the web page by fetching the data from the web server. The developed Warehouse inventory management system is very efficient, it can perform dynamic data Updation and Real Time search operations from the database. Thus the implementation of RFID System of this proposed methodology is not bounded to prototype or laboratory setup, but can also work efficiently in Real world application. The total implementation cost of the developed warehouse inventory management system is very low compared with the present existing models in the marketplace.

5. RESULTS AND ANALYSIS

The product information from the hardware setup arranged at Stockroom 1 and Stockroom 2 is collected in the Raspberry Pi 3 central server and arranged in the form of rows and columns to visualize the Tag number, product description, Stockroom Number, Location and the time stamps of the product on the web page. Instantly as the user scans the specified tag, then all the information on the tag is updated in the database on the web server and is displayed on the web page. The Figure 6 represents the tag numbered 0D0021B13AA7 is being read by the RFID reader and that tag information is transferred to the NodeMcu for processing and Finally sent to the central server.



Figure 6: RFID tags data is reading by the RFID reader

Figure 7 depicts the collected data or information from the two stockroom's and it also provides users the facility to search specific product by typing its tag number on the web page. The information on the web page illustrates that the tag numbered 0D0021B13AA7 updated on the web server symbolizes as product number 4 with a cost of Rs. 400, present in Stockroom Number 1 and its time stamps.

Search:

Page 1 of 4 [Next](#)

S.No	TAG NUMBER	PRODUCT DISCRIPTION	STOCK ROOM NUMBER	Location	Date
1	0D001037547E	product-6>RS-80	1	Location	2017-02-28 20:29:40
2	0D00105A3176	product-8>RS-120	1	Location	2017-02-28 20:29:36
3	0D00103880A5	product-7>RS-600	2	Location	2017-02-28 20:29:33
4	0D001019BEBEA	product-1>RS-100	1	Location	2017-02-28 20:29:31
5	0D0021B13AA7	product-4>RS-400	1	Location	2017-02-28 20:29:27
6	0D00218DD273	product-2>RS-80	2	Location	2017-02-28 20:29:20

Figure 7: Product information displayed on the web page

Figure 8 depicts the detailed information about the product with the attached tag number 0D0021A8D256. If the user wants to know about the detailed information about tag numbered 0D0021A8D256 then with the facility of the search field the user types the tag number 0D0021A8D256 in it. If the tag number matches in the web server then the data is fetched from the database. So that user can easily find the product details, the stockroom number in which the product is stored and also the time stamps of the product with the help of search field provided. The search field is provided for real time search to query data from the database.

Search:

Page 1 of 1

S.No	TAG NUMBER	PRODUCT DISCRIPTION	STOCK ROOM NUMBER	Location	Date
1	0D0021A8D256	product-3>RS-500	2	Location	2017-02-28 20:29:14
2	0D0021A8D256	product-3>RS-500	2	Location	2017-01-31 13:13:41
3	0D0021A8D256	product-3>RS-500	2	Location	2017-01-20 16:43:26
4	0D0021A8D256	product-3>RS-500	1	Location	2017-01-20 16:43:07
5	0D0021A8D256	product-3>RS-500	1	Location	2016-12-29 15:59:20

Figure 8: Tag Numbered 0D0021A8D256 displays the specified results of it on the web page with the search field provided

6. CONCLUSION AND FUTURE SCOPE

The developed Warehouse inventory management system is very efficient, it can perform dynamic data Updation and Real Time search operations from the database with the help of a web server. Thus the implementation of RFID System of this proposed methodology is not bounded to prototype or laboratory setup, but can also work

efficiently in Real world application. The total implementation cost of the developed warehouse inventory management system is very low compared with the present existing models in the marketplace. With the implementation of user-friendly user interface the users can easily spot the tracked product in the Warehouse without much effort. In future, this innovation can be used in several areas in different applications and many enhancements can be done so that it can be made available to all the sectors.

Acknowledgment

This research was supported by Mr.K Sripath Roy and ESSN research group at KL University. I thank the Institute for providing the constant support for this research from the expertise.

REFERENCES

- [1] S. M. Huynh, D. Parry, A. Fong, and J. Tang, "Home localization system for misplaced objects" in Proc. IEEE International Conference on Consumer Electronics, 2014, pp. 462-463.
- [2] Son Minh Huynh, David Parry and A. C. M. Fong, "Novel RFID and Ontology based Home localization System for Misplaced Objects", IEEE Transactions on Consumer Electronics, Vol. 60, No. 3, August 2014.
- [3] Y.X.Lu, T.B.Chen, Y.Meng, "Evaluation guideling system and intelligent evaluation process on the Internet of Things," American Journal of Engineering and Technology Research, vol.11, no.9, pp.537-541, 2011.
- [4] Ramaa.A, Subramanya.K.N, Rangaswamy.T.M, "Impact of Warehouse inventory management system in a supply chain", International journal of computer applications (0975-8887), Vol.54,No.6, September 2012.
- [5] M. Bruccoleri, S. Cannella, G. La Porta, "Inventory record inaccuracy in supply chains: the role of workers' behavior", International Journal of Physical Distribution & Logistics Management, Vol. 44, No. 10, 2014.
- [6] N. Wartha, V. Londhe, "Context-Aware Approach for Enhancing Security and Privacy of RFID", Int'l. J. Engineering and Computer Science, Vol. 4, pp. 10,078-88, 2015.
- [7] Samer S. Saab and Zahi S. Nakad, "A Standalone RFID Indoor Positioning System Using Passive Tags", IEEE Transactions On Industrial Electronics, Vol. 58, No. 5, May 2011.
- [8] J.Gubbi, R. Buyya, S. Marusic, M. Palaniswami, "Internet of Things (IoT): A vision architectural elements and future directions", Future Gener. Comput. Syst., Vol. 29, No. 7, pp. 1645-1660, Sep. 2013.
- [9] K. Stravoskoufos et al., "IoT-A and FIWARE: Bridging the Barriers between the Cloud and IoT Systems Design and Implementation," Proc. 6th Int'l Conf. Cloud Computing and Services Science (CLOSER 2016), 2016, pp. 146 – 153.
- [10] Bandyopadhyay, J. Sen, "Internet of Things: Applications and challenges in technology and standardization", Wireless Pers. Commun., Vol. 58, No. 1, pp. 49-69, 2011.
- [11] P. Yang, "PRLS-INVES: A general experimental investigation strategy for high accuracy and precision in passive RFID location systems", IEEE Internet Things J., Vol. 2, No. 2, pp. 159-167, Apr. 2015.
- [12] A.Ibrahim and D. Ibrahim, "Real-time GPS based outdoor WiFi localization system with map display," Advances in Engineering Software, Vol. 41, pp. 1080-1086, 2010.
- [13] RMautz, "The challenges of indoor environments and specification of some alternative positioning systems," in Proc. 6th Workshop on Positioning, Navigation and Communication, 2009, pp. 29-36.
- [14] R. Tesoriero, J. A. Gallud, M. D. Lozano, and V. M.R.Penichet, "Tracking autonomous entities using RFID technology," IEEE Transactions on Consumer Electronics, Vol. 55, pp. 650-655, 2009.
- [15] L. M.Ni, Y. Liu, Y. C. Lau, and A. P. Patil, "LANDMARC: indoor location sensing using active RFID," Wireless networks, Vol. 10, pp.701-710, 2004.

- [16] D. Fortin-Simard, K. Bouchard, S. Gaboury, B. Bouchard, and A. Bouzouane, "Accurate passive RFID localization system for smart homes," in Proc. IEEE 3rd International Conference on Networked Embedded Systems for Every Application, 2012, pp. 1-8.
- [17] J. Ziegler, M. Graube, and L. Urbas, "RFID as universal entry point to linked data clouds," in Proc. IEEE International Conference on RFID Technologies and Applications, 2012, pp. 281-286.
- [18] N. Fallah, I. Apostolopoulos, K. Bekris, and E. Folmer, "Indoor Human Navigation Systems: A Survey," *Interacting with Computers*, Vol. 25, pp. 21-33, 2013.
- [19] R. Tesoriero, J. Gallud, M. Lozano, and V. Penichet, "Using active and passive RFID technology to support indoor location-aware systems," *IEEE Transactions on Consumer Electronics*, Vol. 54, pp. 578-583, 2008.
- [20] K. Domdouzis, B. Kumar, and C. Anumba, "Radio-Frequency Identification (RFID) applications: A brief introduction," *Advanced Engineering Informatics*, Vol. 21, pp. 350-355, 2007.
- [21] R. Want, "An introduction to RFID technology," *IEEE Pervasive Computing*, Vol. 5, pp. 25-33, 2006.
- [22] P. Solic, Radic, x, J., and N. Rozic, "Software defined radio based implementation of RFID tag in next generation mobiles," *IEEE Transactions on Consumer Electronics*, Vol. 58, pp. 1051-1055, 2012.
- [23] P. Karthika, J. Harriet Rathna Priya and A. Rathinavel Pandian, "Indoor Location Tracking System Using RFID Technology", *International Journal of Engineering Research and Reviews*, Vol. 3, Issue 1, pp: (73-80), January 2015.
- [24] M. Gireesh Kumar, K. Sripath Roy, 2014, "Zigbee Based Indoor Campus Inventory Tracking Using Rfid Module", *International Journal of Engineering Research and Applications(IJERA)*, ISSN 2248-9622, Vol. 4, Iss 7(1), pp 132.