

Improved Single Phase Synchronous Reference Frame Theory Applied to DVR Compensating Voltage Sag of Nonlinear Load

D.N. Katole¹, M.B. Daigavane², S.P. Gawand³ and P.M. Daigavane⁴

ABSTRACT

This paper mainly concentrates on design of improved controller and its implementation based on single phase synchronous reference frame theory (SRFT) for DVR compensating voltage sag particularly for nonlinear load. In case of single phase distribution line with nonlinear load, the complexity of controller's design becomes more serious issue. The present single phase and/or three phase theories applicable to DVR shows poor response to restore voltage sag in case of nonlinear load due to presence of harmonics. Hence restoration of voltage sag in single phase nonlinear load connected system has been a serious concern. Therefore, new controller for DVR has been proposed incorporating effective design concept for fundamental component extraction in case of nonlinear load. The single phase SRFT based main controller for DVR works on two separate closed path viz. feed forward path for quick transient response and feedback path for reducing the steady state error. Moreover, pre-sag mitigation strategy of DVR has been adapted through these two aforementioned paths. Complete design of proposed controller is based on phasor analysis. It also consist of proportional integral (PI) controller to reduce the error in the DC-link voltage during compensation time. The controller performance has been verified in MATLAB Simulink for both types (linear and nonlinear) of load. The results obtained indicates that the proposed controller is effective in its performance.

Keywords: Power quality, Voltage sag, DVR, Single phase SRFT based controller, Sinusoidal pulse width modulation, Non-linear load.

1. INTRODUCTION

In distribution system power electronics based custom power devices plays a major role in present modern industries for upgrading the power quality during production process. Power quality issue has major impact on sensitive industrial and utility end loads in distribution line. Major power quality problem amongst voltage sag, voltage swell, harmonic distortion, flicker, spikes etc. is the single phase unbalance voltage sag. Moreover, compensation of unbalance sag in three phase system makes the design process complex. The conventional theories which are generally used in compensation of unbalance voltage sag with the utilization of custom power devices shows inefficient performance in case of nonlinear load. As nonlinear load generates the harmonic components, the detection and correction of voltage at load end becomes improper.

The characteristic of voltage sag is sudden decrease in rms voltage magnitude which remains in between half a cycle and few seconds [1]. Two major parameters of voltage sag are its magnitude and time during which it sustain. However, the sag magnitude is not constant, due to the induction motor load [2]. Mostly occurring single phase short circuit faults have become one of the most important problem which ultimately results in voltage sag facing industrial customers. Disturbances due to short circuit of line, sudden change in the load and starting of inductive type load [3] has effect on voltage waveform causing problems related

¹ Research Scholar, Dept. of Electrical Engg., G.H.R..C.E, Email: dn_katole@rediffmail.com

² Principal, G.H.R.I.E.T., Hingna, Nagpur, Maharashtra, India, Email: mdai@rediffmail.com

³ S.P. Gawande, Y.C.C.E. Nagpur, M.S. India, Email: spgawande_18@yahoo.com

⁴ G.H.R.C.E. Nagpur, M.S. India, Email: prema.daigavane@raisoni.net

with the operation of sensitive electrical devices. One of the custom power device known as DVR can eliminate all types of voltage sags and in dip sag it minimizes the risk of load tripping. The controller of DVR requires fast response also it has to take care of large variation in voltage magnitude with phase change in different phases which is to be compensated hence the controller design method is not straightforward. Industrial and sensitive load need constant rms voltage magnitude, constant frequency and balance voltage with a constant rms value for quality production.

Dynamic Voltage Restorer (DVR) equipment used in distribution line, penetrates the voltage in series with system voltage, providing the most cost effective resolution for mitigation of voltage sag with improved power quality level required by utility customer [4]. When a fault happens on one of the load in distribution network, sudden voltage sag will appear on adjacent loads. DVR installed before a sensitive load, restores the line voltage to its nominal value in few milliseconds. Most of the occurring sags are nonsymmetrical and accompanied by a phase change. For mitigation of all types of sag various control strategies for DVR have been suggested in [5] to [7] but all are three phase based controller. Although the voltage sag is compensated tightly by the various controllers but it is at the cost of more switching losses in the voltage source inverter (VSI). Moreover, in case of mostly occurring single phase unsymmetrical fault three phase based controller creates complexity in controlling the load voltage. Hence this paper focuses on a single phase synchronous reference frame (SRF) d-q based controller which is analyzed and designed for exact restoration of nonlinear load voltage.

The performance of the proposed controller is evaluated in the MATLAB software. The results after its study indicates that the controller proposed can be advantageous for following points.

- If phase sequence is properly tracked by the PLL then the proposed controller can be utilized for three phase system.
- It regulates all the sequence component in considerably short time (7ms) with zero steady error.
- As it is single phase based it can energize only one phase which reduces the switching losses and increases the time of compensation.
- Decoupled control of magnitude and angle of injected voltage reduces dc link error. This limits modulation index resulting in less distortion in injected voltage.

2. OPERATION OF DVR

The operation of DVR as a custom power device [3] is to use voltage source inverter based controllers in the medium voltage distribution system aiming to supply reliable and high quality power to sensitive users [4]. The basic aim of the DVR is compensate required load voltage in which the compensating voltage is in series with the supply voltage to regulate the load terminal voltage. DVR could be the effective device to overcome some of the major power quality problems such as voltage sag, voltage swell, distortion and unbalance in supply and load with the injecting active and/or reactive power into the system [5]. The schematic configuration of system with complete structure of DVR connected in series with line is depicted in Fig. 1. In general, DVR consists of energy storage system, VSI, filters and series injection transformer [6].

Due to occurrence of fault (balance or unbalance) or starting of Induction motor or change in load, supply voltage V_s changes and DVR injects dynamically controlled voltage V_{inj} in series with the supply voltage through a series transformer to correct the sag in such a way that the reference load voltage can be obtained at the utility end [7]. However, not only voltage injection but also reactive and/or active power injection is needed which is provided by energy storage system (ESS) [8]. The DVR however itself is capable of generating the reactive power but the required active power is supplied through the ESS of the DVR. When the injected voltage is in phase with the supply voltage, the desired load voltage correction can be possible with a minimum voltage injection but it may require a considerable amount of active power

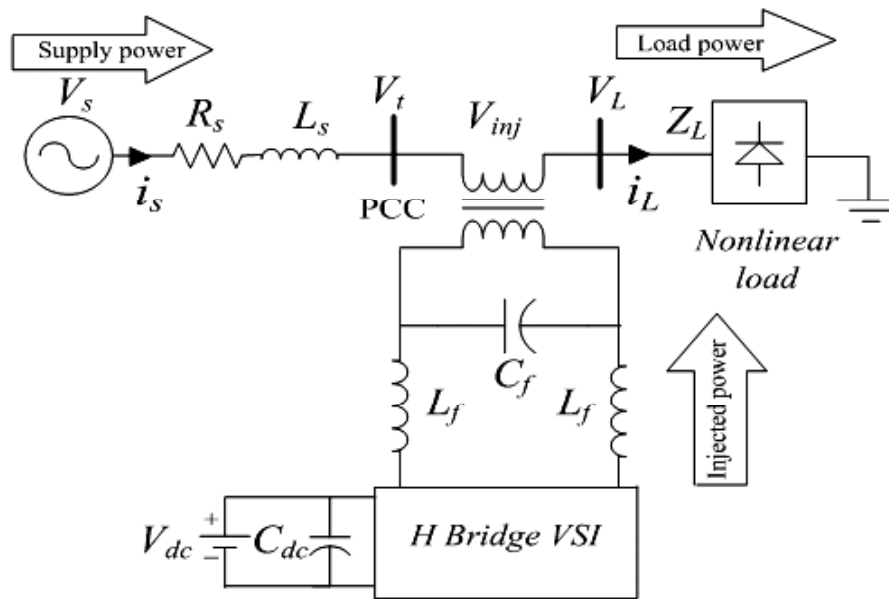

Figure 1: Single phase system configuration with DVR

injection into the system [5]. When the injected voltage leads the supply voltage, the same correction however can be possible with a lower value of active power. This is made possible at an expense of higher magnitude of voltage injection.

In general, the active and reactive power flows are controlled by the angle between the voltage that is injected in series with the line and the line current. For example, if the injected voltage is in phase with the current, only active power is changing with the line. Otherwise, if the injected voltage is in quadrature with the current, nothing more than reactive power will change with the line, moreover minimum active power will be required if the power factor of supply is unity [6]. Voltage compensation by DVR will be in quadrature with the load current in case of no energy storage device as given in [13]-[14] but in that case large injected voltage magnitude is required to mitigate the voltage sag. In addition, reactive power compensation is only effective for small voltage sag. So injection of voltage at the same phase instant for deeper and longer voltage sag or swell and voltage with phase jump requires active power for which the energy storage device is necessary.

3. DIFFERENT CONTROL METHODS RELATED TO DVR

3.1. In-phase compensation method

The minimization of voltage amplitude can be realized with this method where DVR compensate load voltage with a minimum voltage injection [10]. The voltage is compensated in phase to post sag value of PCC voltage i.e. the phase change in PCC voltage is not compensated. Hence by this method injected voltage magnitude can be minimized. But in most of the cases, a voltage sag occurs with a phase change, therefore this method produces distortions on to the load voltage leading to transients and circulating currents. Moreover for sensitive load, in phase compensation is hardly beneficial as it could lead to tripping of the load. Note that, to realize this compensation strategy, the phase-locked loop (PLL) has to be synchronized to the grid voltage itself, and therefore, must not be locked to the pre-sag grid voltage during the compensation.

3.2. Pre-sag compensation method

The most prominent solution for voltage sag compensation is to maintain the same amplitude and the phase of the voltage before the sag. This solution is provided by Pre-sag compensation through which load voltage is exactly restored.

The pre-sag compensation does not change the phase during compensation period which leads to less distortion at the load end resulting in no transients and circulating current. In this case PLL must be synchronized with the PCC voltage. At the instant of disturbance, PLL must be locked so as to restore the phase angle [11]. But in this method the DVR has to deliver higher compensation voltage amplitude depending on voltage phase change. Therefore the controller has to be designed for higher compensation voltage which results in less energy extraction from DC link as compared to in phase compensation method.

3.3. Energy Optimized Compensation

In this strategy the injected voltage is in phase quadrature with the load current. In other words the DVR will provide as much reactive power as possible resulting in minimization of active power needed from DC link. The main concept of this compensation is to draw as much active power from the grid as possible. But the disadvantage is it can only be applied to shallow voltage sag because dip sag requires large compensated voltage magnitude which ultimately increases the voltage rating of capacitor. Also the phase of the load voltage is shifted resulting in steady state error causing tripping of critical nonlinear load. Beside the enormous advantages of not requiring active power and unlimited compensation time this strategy has in most cases two major disadvantages. First is phase change occur and second is requirement of injected voltage amplitude is quite high. Furthermore, the compensation with pure reactive power is only possible for shallow sags. If a deep sag occurs, a large amount of active power is also needed with this strategy.

As per the discussion optimized controller must be adapted for better dynamic performance of DVR [18].

4. CONTROL SYSTEM

The configuration of single-phase DVR consist of four IGBT switches based voltage source H-bridge inverter (VSI) with self-supporting DC link connected in series with single phase transformer as presented in Fig. 1. To deal with the power quality problems in single phase system, several control methods are available preferably for shunt compensation viz. active power filter [17] but very few are reported in case of series compensation. Generally instantaneous reactive power (and/or p-q theory) theory (IRPT), originally developed for three-phase system by Akagi et al. [15]-[16] and its modified p-q-r theory are mostly used in control method for DVR but this theories does not give perfect information of phase just at the instant of occurrence of fault. Also instantaneous p-q theory is limited to three phase system and less reported in single phase system. Hence in this paper single phase synchronous reference frame d-q theory (SRFT) as described in [19] for three phase system has been adapted. The main controller consist of two decoupled sub-controllers viz. feed-forward controller to improve better transient response and feed-back controller to minimize steady state error. The DC link capacitor is provided to store the energy required by the DVR during compensation of voltage sag as it get discharge with the decrease in V_{dc} voltage. The DC-link capacitor is charged to 300 V. The discharge in V_{dc} is due to some power loss in inverter switch, series transformer and $\pi(L-C-L)$ filter. The $\pi(L-C-L)$ filter at the output of VSI is utilized to reduce the effect of switching frequency and to smoothen the voltage waveform from higher order harmonics. The controller

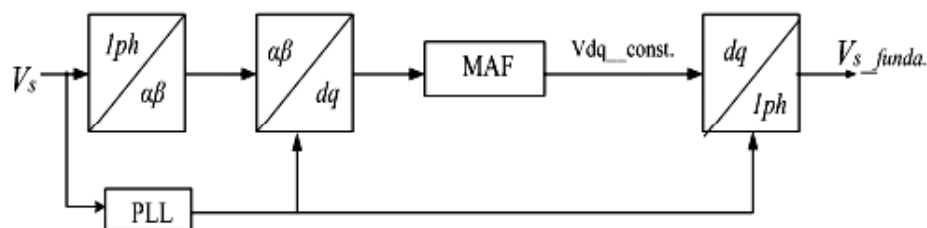

Figure 2: Fundamental positive sequence component extraction

focuses mainly on quick detection of sag and exact restoration of load voltage without any change in phase during compensation period. For aforementioned condition exact reference voltage generation is needed by the controller. The proposed controller fulfils the demand of exact reference voltage generation as discussed further in this section.

4.1. Generation of Single Phase SRF dq component

In the proposed controller with the existing phase (considered α phase), other orthogonal fictitious phase is created which is considered as β phase. This orthogonal β phase generation has been done with the quarter cycle time delay method. Generation of α - β quadrature phases resembles the Clarke's transformation in three phase theory. Accordingly this α and β instantaneous values are transformed into synchronous reference frame (SRF) based d-q components.

Here clark and then park transformation is implemented on one phase where the reference angle is obtained through single phase PLL as shown in Fig. 2. In order to obtain the fundamental positive sequence component of distorted PCC voltage due to presence of nonlinear load, the variable dc value along d axis due to presence of nonlinear load has been kept constant with the application of Moving-Average Filter (MAF).

4.2. Moving Average Filter

MAF consist of following blocks: integration block, transport delay block, subtraction block and division block as presented in Fig. 3. The output of the transport delay block is the input signal delayed by $1/n$ of T , where T is the period of the fundamental component of the input signal and 'n' is an integer number. The moving average of two input values calculated over the time interval T/n gives the output of MAF filter. Thus, the difference between the output of the integration block and the output of the transport delay block represents the integration of the input signal over the time interval $[t-T/n, t]$. In the division block, the output of the subtraction block is divided by the integration interval T/n . In [11] MAF is used to improve the dynamic response of a three-phase three-wire shunt APF and in [12] MAF has also been used to improve a positive-sequence component detector in an unbalanced three-phase system.

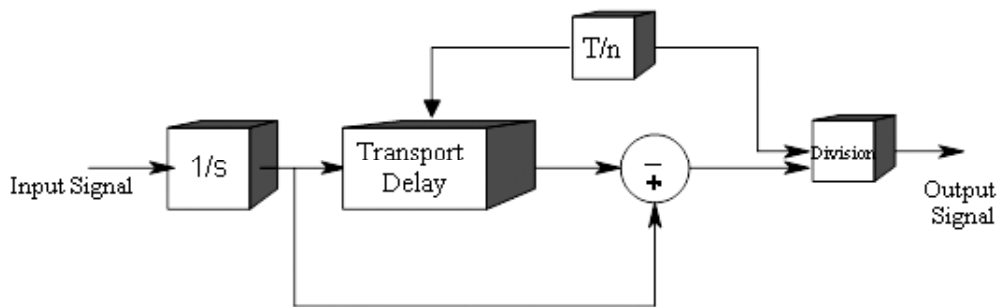

Figure 3: Block diagram of the moving average filter (MAF)

4.3. Voltage Sag Detection Method

The SRF d-q voltage at PCC is used for detection of sag. It is based on the rms of the error vector which detect symmetrical and asymmetrical sags with the consideration of effect of phase change. The instant of sag detection is given by

$$|V_{dq_error}| > V_{Threshold}$$

The threshold value of supply voltage is kept 95% to effective detection and correction of voltage sag.

4.4. Reference Load voltage generation

The fundamental positive sequence reference load voltage is restored by phasor analysis based Load voltage controller. This controller works on two different sub-controller loops, one as feed-forward loop for faster transient response and other as feedback loop for zero steady state error. Each of the aforementioned phasor control loop is comprised of magnitude control loop and phase angle control loop. Both these loops are decoupled with each other. The phasor analysis based proposed controller incorporating single phase SRF d-q theory is shown in Fig 4. In the controller 20 kHz has been used as sampling frequency and 8 KHz as switching frequency. The controller requires measurement of three parameters viz. single phase rms voltage at the terminal (PCC) bus, load voltage and dc link voltage.

The controller actually based on pre-sag compensation method, where the injected voltage phasor by the DVR, is the complex difference of supply voltage and pre-sag supply voltage phasors. The value of magnitude of injected voltage (V_{inj1}) and angle (θ_{inj1}) are obtained from feed forward loop and V_{inj2} is calculated by subtracting actual $V_d - V_q$ values of supply voltage from reference fundamental load voltage value in synchronous reference frame. Two PI controller are used to eliminate the steady state errors of the magnitude and phase angle of load voltage. The parameters of PI controller are set simply by trial and error method so as to get zero steady state error in dc signal in order to achieve fast response without any overshoot. The outputs of the PI controllers are added to output of feed-forward loop to achieve injected voltage reference signal. This signal is compared with the triangular carrier signal so as to get the pulses required for the switching of inverter switches to get the injected voltage.

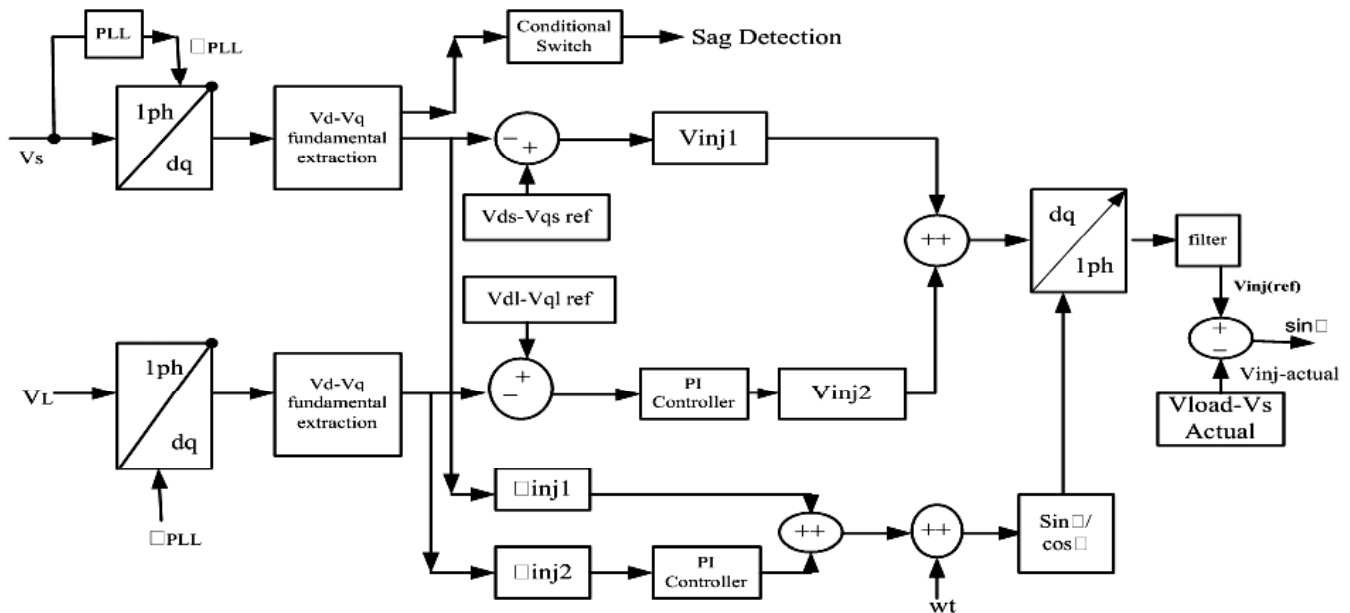

Figure 4: MATLAB based model of proposed control method

5. SIMULATION RESULTS

The considered single phase system for simulation under MATLAB Simulink environment consists of a source, a bus, and two parallel loads as shown in Fig 5. The SIMPOWER SYSTEM present in MATLAB [20] has been utilized for analysis. When LG phase fault occurs in one line, the other load experiences voltage sag at PCC. For the performance confirmation of DVR with proposed modified single phase SRF d-q theory based controller, it has been simulated in MATLAB. The simulations are performed for two load conditions viz. linear and nonlinear load. The results of which are shown in Figs. 6-7 and in Figs. 8-9 for linear and nonlinear load respectively. The parameters considered for simulation is given in appendix I. Due to fault the PCC voltage experience the sag of 55% from instant 0.05sec to instant 0.30sec which

nearly covers up to 12 cycles as shown in Fig. 6(a). It can be clearly stated from Fig. 6(b) that the DVR is restoring the load voltage to its predefined value without any phase change represented in Fig. 6(c). It is clearly noted that the controller is initiated with approximately one cycle delay because of quarter cycle delay in β component generation. From the overall scenario of results, it can be further stated that the load voltage is tightly restored to its reference value. The DC-link voltage is maintained constant to its reference value given in Fig. 7(a), load current and generation of fundamental $\alpha\beta$ component from it has been shown in Figs. 7 (b-c) for linear load.

For further judgment half bridge diode rectifier is connected across load to make it nonlinear. The Fig. 9(b) indicates the nonlinear nature of load current. The $\alpha\beta$ component of nonlinear load current has been generated by quarter cycle time delay method represented in Fig. 9(c). Fig. 8(a) depicts approximately 12 cycles sag generation for the same time instants as discussed for linear load. With the application of proposed modified controller for DVR, results for injected voltage and restored load voltage are shown in Fig. 8(b) and Fig. 8(c). It can be clearly notified that in case nonlinear load there is no delay observed in reference load voltage restoration.

From the overall observation and discussion of results, it can be further stated that the load voltage is maintained at its rated RMS value. The load voltage is observed to be satisfactory due to exact voltage injection by DVR resulting in exact restoration of load voltage to its reference value of 200 V. The DC-link

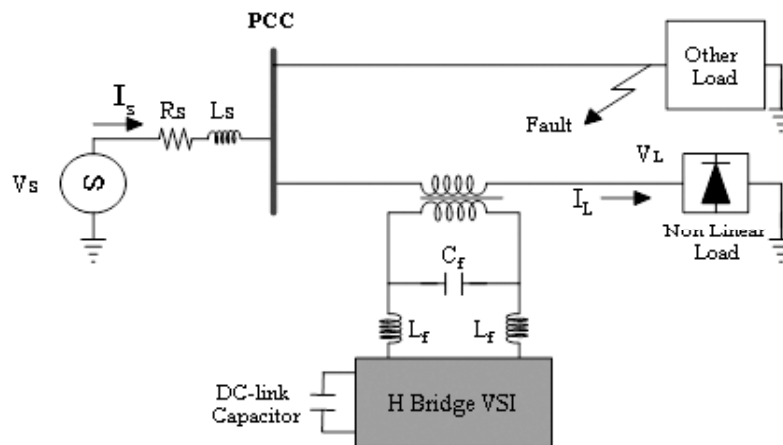

Figure 5: System under consideration.

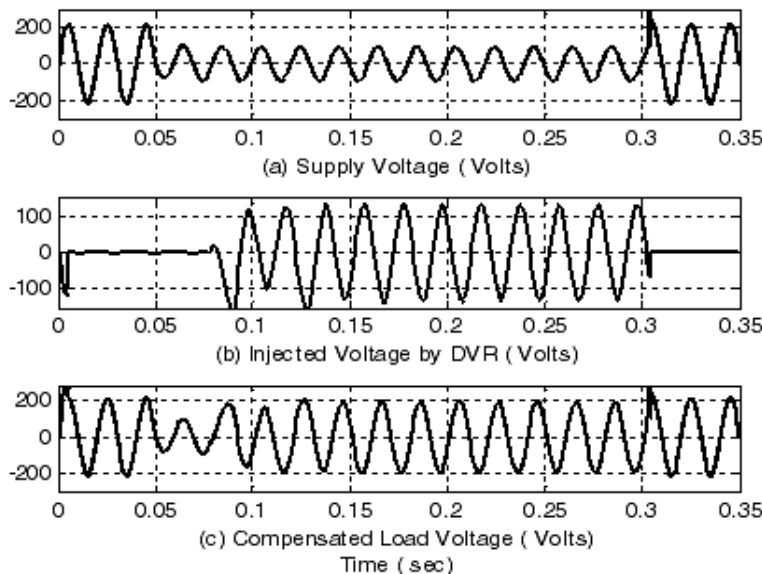

Figure 6: Behavior of system with DVR for linear load by proposed controller.

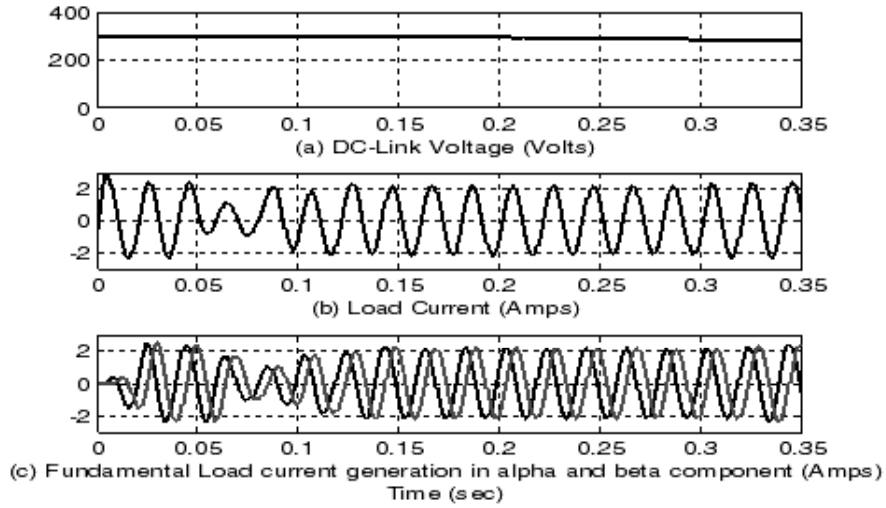

Figure 7: DC-link voltage and load current in case of linear load.

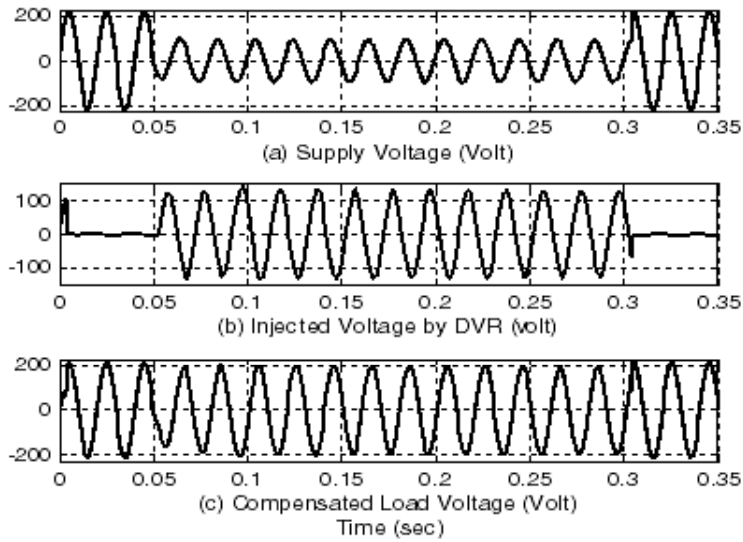

Figure 8: Behavior of system with DVR for nonlinear load by proposed controller.

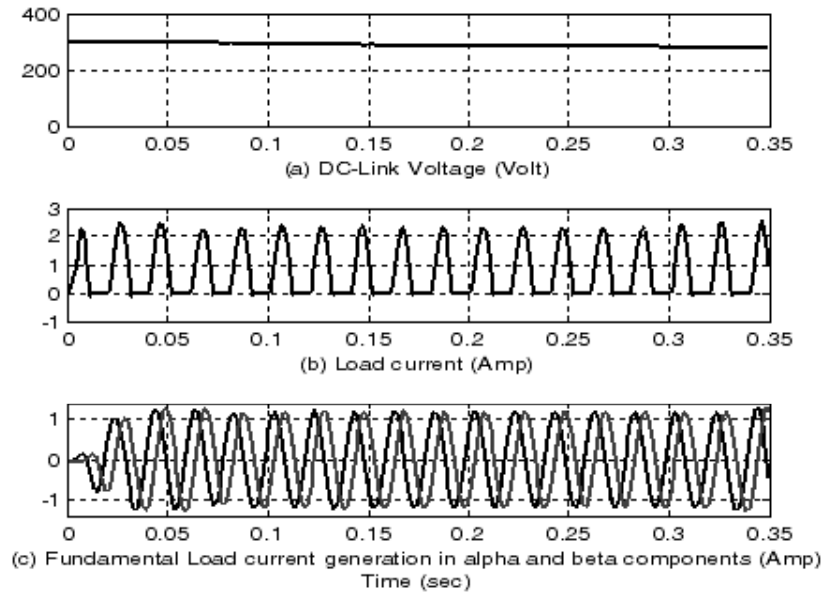

Figure 9: DC-link voltage and load current in case of nonlinear load.

voltage is maintained constant to its reference value of 300V in Fig. 9(a), generation of fundamental $\alpha\beta$ component of load current from nonlinear current is shown in Fig. 9(c).

6. CONCLUSION

The generalized single phase SRFT based d-q controller for DVR with the presence of nonlinear load has been analyzed and simulated successfully for nonlinear load. The controller design is completely based on phasor analysis of pre-sag compensation method. The controller is based on decoupled feed forward and feedback control technique. Also no freezing of PLL has been carried out to get the information of phase value prior to occurrence of fault. This reduces the complexity of the controller. The extensive simulation and investigation has been carried out by comparing three phase SRF theory with the proposed single phase SRF d-q theory. The phasor based control method incorporating single phase SRF d-q theory for DVR has been validated for nonlinear load with the restoration of reference load voltage without any phase change. The performance of proposed controller for DVR has been found better restoring nearly exact voltage at sensitive load. Simulation results shows the efficacy of DVR in voltage sag compensation in case of nonlinear load.

APPENDIX I

System Parameter

Power Supply	1 phase, 215 V(rms), 50 Hz
Line impedance	0.2 ohm, 1 mH
Other Load Voltage	215 Vrms, 50 Hz, P = 800 W, Q = 200 VAR
Critical load Voltage	215 Vrms, 50 Hz, P = 1000 W
Series transformer	500 VA, 50 Hz, 230/230 Vrms, X = 1%
LC ripple filter	25 uH, 80 uF
DC Link value	$V_{dc} = 300$ V, $C_{dc} = 10$ mF
Switching Frequency	8 KHz
Sampling Frequency	20 KHz

REFERENCES

- [1] M. H. J. Bollen, "Understanding Power Quality Problems—Voltage Sags and Interruptions" Piscataway, New York: IEEE Press, 2000.
- [2] M. Bollen, "The influence of motor reacceleration on voltage sags." IEEE Trans. Industry Appl., vol. 31, no. 3, pp. 667-674; 1995
- [3] H. Hingorani "Introducing custom power" IEEE spectrum, vol.32 no.6 June 1995 pp. 41-48.
- [4] N.G.Hingorani and L. Gyugyi, "Understanding FACTS: Concepts and Technology of Flexible AC Transmission Systems", 1st edition, The Institute of Electrical and Electronics Engineer, 2000.
- [5] Jurado, manuel Valverde : Voltage Correction By Dynamic Voltage Restorer Based on Fuzzy Logic Controller": IEEE Transaction Industrial Electronics, may 2003.
- [6] M.H.Haque "Compensation of distribution system voltage sag by DVR and DSTATCOM" Power Tech Proceedings, 2001 IEEE Porto, Vol. 1 10-13, Sept. 2001 Pages 5 pp.
- [7] Satish Samineni, B. K. Johnson "Modeling and Analysis of a Flywheel Energy Storage System for voltage Sag Correction", IEEE Trans. industry applications, vol. 42, no. 1, Jan/Feb. 2006.
- [8] R. S. Weissbach, G. G. Karady and R. G. Farmer, "Dynamic Voltage Compensation on Distribution Feeders using Flywheel Energy Storage" IEEE transactions on Delivery, Vol.14, No.2, April 1999.
- [9] Bhim Singh, Pychadathil Jayaprakash, D. P. Kothari, Ambrish Chandra, Kamal-Al-Haddad, "New Control Algorithm for Capacitor Supported Dynamic Voltage Restorer" Journal of Electromagnetic Analysis and Applications, 2011
- [10] Rosli Omar, Nasrudin Abd Rahim, "Mitigation of voltage sags/swells using Dynamic Voltage Restorer (DVR)" ARPN Journal of Engineering and Applied Sciences, Vol. 4, No. 4, June 2009.

- [11] C. Zhan, V.K. Ramachandramurthy, "Dynamic voltage restorer based on voltage-space-vector PWM control." IEEE Trans. Industry applications, vol. 37, no. 6, Nov. 2001.
- [12] Mostafa I. Marei, Ehab F. El-Saadany, "A New Approach to Control DVR Based on Symmetrical components Estimation." IEEE Trans. Power delivery, Vol. 22, No. 4, Oct. 2007.
- [13] S.S. Choi, B.H. Li, and D.M. Vilathgamuwa "Dynamic voltage restoration with minimum energy injection," IEEE Trans. Power Syst., vol. 15, pp. 51–57, Feb. 2000
- [14] M.H. Haque "Voltage Sag Correction by Dynamic Voltage Restorer with minimum power injection", IEEE 2001.
- [15] V. Khadkikar, A. Chandra, B.N. Singh, "Generalised single-phase p-q theory for active power filtering: simulation and DSP-based experimental investigation" IET Power Electron., 2009, Vol. 2, No. 1, pp. 67–78.
- [16] J.Bangarraju and V. Rajagopal, B.Nithin, "Mitigation of Supply Disturbances using Three-Leg VSC based DVR from Single Phase P-Q Control Strategy" International Conference on Electrical, Electronics, Signals, Communication and Optimization (EESCO) – 2015
- [17] Sergio Augusto Oliveira da Silva, Rodrigo Augusto Modesto "A Comparative Analysis of SRF-based Controllers Applied to Active Power Line Conditioner" IEEE, 2008.
- [18] Christoph Meyer, Student Member, IEEE, Rik W. De Doncker, Fellow, IEEE, Yun Wei Li, Member, IEEE, and Frede Blaabjerg, Fellow, IEEE, "Optimized Control Strategy for a Medium-Voltage DVR—Theoretical Investigations and Experimental Results," IEEE Trans. Power Electron., vol. 23, no. 6, Nov. 2008.
- [19] Parag Kanjiya, Bhim Singh, Ambrish Chandra, and Kamal Al-Haddad, "SRF Theory Revisited" to Control Self-Supported Dynamic Voltage Restorer (DVR) for Unbalanced and Nonlinear Loads. IEEE Trans. Ind. Appli., vol. 49, no. 5, Sept./ Oct. 2013
- [20] TEQSIM International Inc., "Power System Blockset User's Guide", 2001.

