



## International Journal of Control Theory and Applications

ISSN : 0974-5572

© International Science Press

Volume 9 • Number 47 • 2016

### Robotic Arm Design and Simulation Using Matlab/Simulink for Drones

\*A Kranthi Kumar, \*T. Pitchaiah and @N. Narayana Rao

Dept. of \*Electronics and Communication Engineering , @ Mechanical Engineering, Vignan's Foundation for Science Technology and Research University, India-522213, E-mail: tp1977\_ece@yahoo.com

**Abstract:** Now days, Unmanned Aerial Vehicles (UAVs) play a major role in many applications such as civilian, military and agriculture. Present-day unmanned vehicles have longer operational duration and require less maintenance than earlier models and are more fuel-efficient. These UAVs (aircraft) can be deployed in a number of different terrains and may not require prepared runways. In Unmanned Aerial Vehicles to pick and place of an object in required location it needs a Robotic Arm. Arm plays a major role in all UAV based applications. The main objective of this paper is to develop robotic arm for pick and place an object from one place to another place which is required in UAV applications. This paper concentration on design of 3R (Three- Joint) revolute type with 6 degree of freedom (DoF). The robotic arm was designed based on kinematics, dynamics by using solidworks and simulations are done using Matlab/Simulink. The simulation results shows that the designed arm is working as per designed specifications with an error of  $\pm 3^0$ .

**Keywords:** ARM, DoF, Drone, UAV, 3R.

#### 1. INTRODUCTION

Unmanned Aerial Vehicles (UAVs) assume a noteworthy part in any action like video recording, Aerial study, horticulture applications, regular citizen study and so on. While these terms are utilized conversely as a part of the news media, the individuals from the Association for Unmanned Vehicle Systems International (AUVSI) rush to call attention to that the expression “DRONE” (Dynamic Remotely Operated Navigation Equipment) was initially begat to allude to pilotless aircraft utilized for “target” rehearse by the military while an unmanned vehicle incorporates the innovation on the ground, regularly with a human at the controls.

The mix of more prominent adaptability, bring down capital and lower working expenses could permit unmanned vehicles to change fields as assorted as urban framework administration, cultivating, and oil and gas investigation to give some examples. The utilization of UAVs later on could be “a more dependable way to deal with certain airspace operations from a natural, environmental and human hazard point of view.”

Unmanned vehicles have longer operational length and require less upkeep than prior models and are more fuel-productive. These flying machine can be conveyed in various distinctive territories and may not require arranged runways.

UAVs are as of now being utilized as a part of an assortment of uses, and numerous more ranges will profit by their utilization, for example, Wildfire mapping, Agricultural observing, Disaster administration, Thermal infrared electrical cable reviews, Law implementation, Telecommunication, Weather checking, Aerial imaging/mapping, Television news scope, brandishing occasions, moviemaking, Environmental observing, Harvesting fields.

The robots are very useful for each and every activity going on this world. So these robots play a crucial role in industries, space technology and medical equipment etc. As an example in industries, at 2000°C humans are unable to do activities at such temperature robots can do the task as per our requirement. While in space robots can do anything like photography, measuring of temperature and weather conditions etc. This paper describes about designing of 3R manipulator robot which has six degrees of freedom.

In 3R manipulator robot to connect, it needs three joints part assembly is required in Solidworks platform. After completing the part assembly the saved design is imported to Matlab software using a “sim-mechanic link”. It generates a model of the circuit automatically based on imported design in Matlab. For this model the angles are set in revolute joint block for the movement of the 3R manipulator robot. These angles can be obtained by applying kinematics to the 3R manipulator robot.

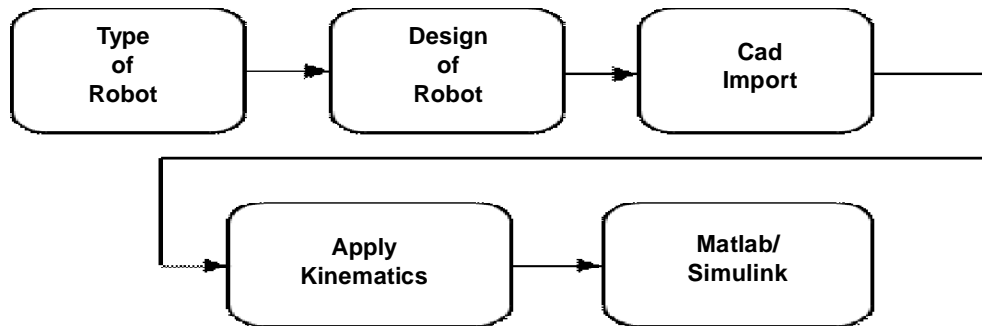

**Figure 1: Block diagram**

Kinematics is of two types in robotics which are forward kinematics and inverse kinematics. For 3-R robot, forward kinematics are used to find out the joint angles for three joints and then moves to destination by knowing the link length and position of the object. Inverse kinematics is the reverse operation to forward kinematics means which finds the position and return back to actual position by knowing the link length and joint angle of each joint. Based on these angles, link length and position the robot can move as per our requirement. This total procedure as shown in above Fig. 1.

## **2. DESIGN PROCEDURE**

These steps are followed to design a robotic arm as shown in below Fig. 2. as flow chart.

### **(A) Design of Robotic Arm**

First each part of robotic arm designed in Solidworks and these whole parts are assembled as per our requirement. The names of the parts are base, link 1, link 2, link 3 and end effector. As shown in below Fig. 3.

### **(B) Kinematics**

Kinematics is the relationships between the positions, velocities, and accelerations of the links of a manipulator, where a manipulator is an arm, finger, or leg. Robot kinematics are two types these are forward kinematics and inverse kinematics, here forward kinematics is used.

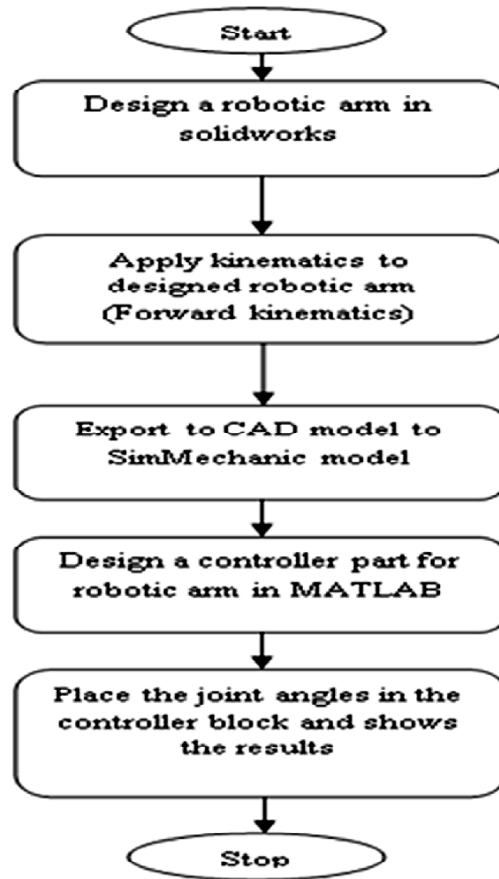

Figure 2: Flow chart for design of robotic arm

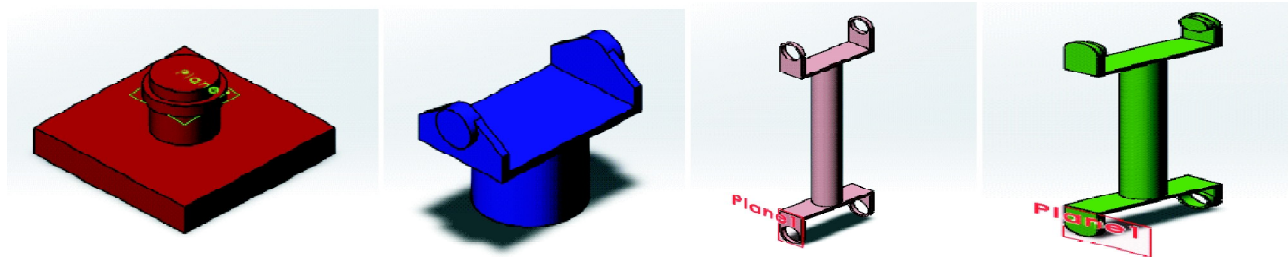

Figure 3: Design of Base, Link 1, Link 2, Link 3 in solid works

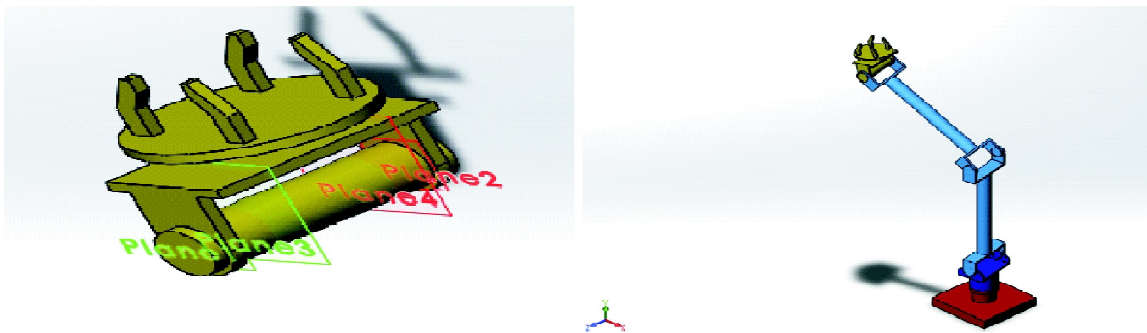

Figure 4: Design of End effector and robotic arm in solidworks

**(C) Forward kinematics**

Forward kinematics is nothing but by knowing the link length and joint angles to find the position and orientation of robotic arm.

**(D) Link Transformation Matrices**

Finding the link parameters and joint parameters of the robotic arm, based on that parameters calculate the transformation matrices of each joint present in the robotic arm. After getting these matrices and add these matrices based on the Denavit-Hartenberg parameters. Link transformation matrices for robotic arm and end effector as shown in below Fig. 5.

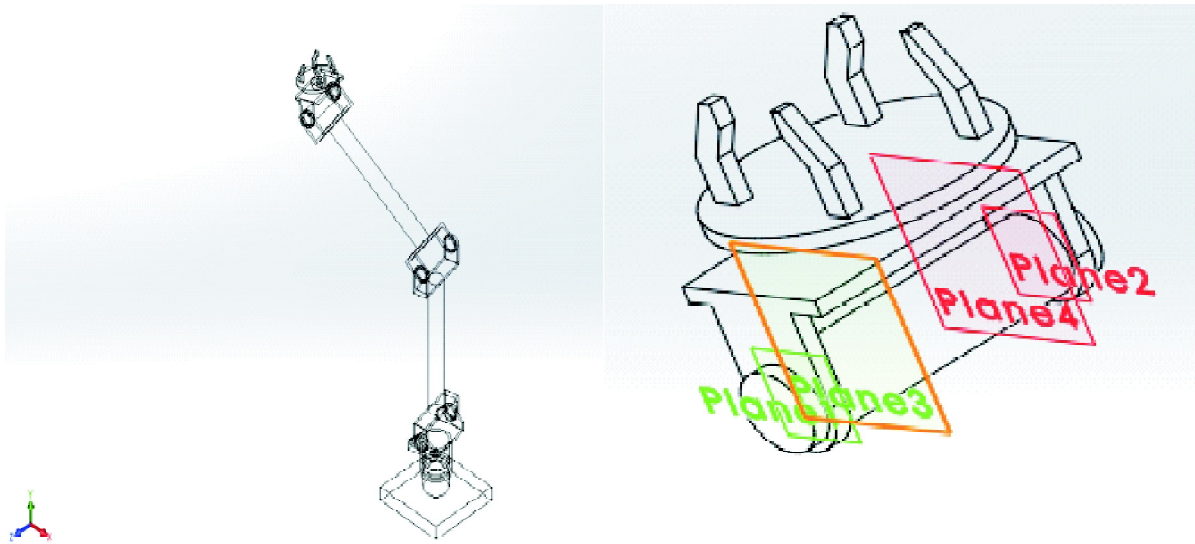

**Figure 5: Schematic representation of robotic arm and gripper**

**Table 1**  
**Link parameters and joint parameters**

Link	Link parameters			Joint parameters
$i$	$\alpha_{i-1}$	$a_{i-1}$	$d_i$	$\theta$
1	0	0	0	$\theta_1$
2	0	$l_1$	0	$\theta_2$
3	0	$l_2$	0	$\theta_3$

The basic transformation matrix for robotic arm is given below

$${}^{i-1}[T] = \begin{bmatrix} C\theta_i & -S\theta_i & 0 & a_{i-1} \\ s\theta_i C\alpha_{i-1} & C\theta_i C\alpha_{i-1} & -S\alpha_{i-1} & -S\alpha_{i-1} d_i \\ s\theta_i S\alpha_{i-1} & C\theta_i S\alpha_{i-1} & -C\alpha_{i-1} & -C\alpha_{i-1} d_i \\ 0 & 0 & 0 & 1 \end{bmatrix} \tag{1}$$

Substituting  $i = 1, a_0 = 0, \alpha_0 = 0, d_1 = 0$  in above matrix

We get

$${}^0_1[T] = \begin{bmatrix} c_1 & -s_1 & 0 & 0 \\ s_1 & c_1 & 0 & 0 \\ 0 & 0 & 1 & 0 \\ 0 & 0 & 0 & 1 \end{bmatrix} \quad (2)$$

Similarly, for  $i = 2$ ,  $a_1 = l_1$ ,  $\alpha_1 = 0$ , and  $d_2 = 0$  we get

$${}^1_2[T] = \begin{bmatrix} c_2 & -s_2 & 0 & l_1 \\ s_2 & c_2 & 0 & 0 \\ 0 & 0 & 1 & 0 \\ 0 & 0 & 0 & 1 \end{bmatrix} \quad (3)$$

And finally, for  $i = 3$ ,  $a_2 = l_2$ ,  $\alpha_2 = 0$ , and  $d_3 = 0$  we get

$${}^2_3[T] = \begin{bmatrix} c_3 & -s_3 & 0 & l_2 \\ s_3 & c_3 & 0 & 0 \\ 0 & 0 & 1 & 0 \\ 0 & 0 & 0 & 1 \end{bmatrix} \quad (4)$$

The transformation matrix  ${}^3_{Tool}[T]$

$${}^3_{Tool}[T] = \begin{bmatrix} 1 & 0 & 0 & l_3 \\ 0 & 1 & 0 & 0 \\ 0 & 0 & 1 & 0 \\ 0 & 0 & 0 & 1 \end{bmatrix} \quad (5)$$

To find the transformation matrix  ${}^0_3[T]$ , we simply multiply  ${}^0_1[T] {}^1_2[T] {}^2_3[T]$  and get

$${}^0_3[T] = \begin{bmatrix} c_{123} & -s_{123} & 0 & l_1c_1 + l_2c_{12} \\ s_{123} & c_{123} & 0 & l_1s_1 + l_2s_{12} \\ 0 & 0 & 1 & 0 \\ 0 & 0 & 0 & 1 \end{bmatrix} \quad (6)$$

Finally, to obtain  ${}^0_{Tool}[T]$ , we multiply  ${}^0_3[T] {}^3_{Tool}[T]$  and get

$${}^0_{Tool}[T] = \begin{bmatrix} c_{123} & -s_{123} & 0 & l_1c_1 + l_2c_{12} + l_3c_{123} \\ s_{123} & c_{123} & 0 & l_1s_1 + l_2s_{12} + l_3s_{123} \\ 0 & 0 & 1 & 0 \\ 0 & 0 & 0 & 1 \end{bmatrix} \quad (7)$$

### 3. CAD TRANSLATOR

Computer-aided design (CAD) tools allow to model machines geometrically as assemblies. Although this approach is excellent for geometric modeling, it is difficult to incorporate controllers and perform dynamic simulations. Simulink and SimMechanics use a block diagram approach to model control systems around mechanical devices and simulate their dynamics. CAD translator enables to translate CAD assemblies from CAD platform into a Physical Modeling XML file compatible with SimMechanics, which generates a SimMechanics block diagram model from XML file to simulate the dynamics of the CAD assembly in the Simulink environment. The CAD translator is designed to work with the CAD platform. The translator and its associated help files are independent of MATLAB and any MATLAB component.

#### (A) CAD-To-SimMechanics Translator

The translator transforms geometric CAD assemblies into Simulink block diagram models. The intermediary between a CAD assembly and its SimMechanics model is XML file in a special Physical Modeling format. Using the translator with a CAD assembly involves two steps:

Exporting the assembly from the CAD platform into a Physical Modeling XML file. This XML file later used in SimMechanics.

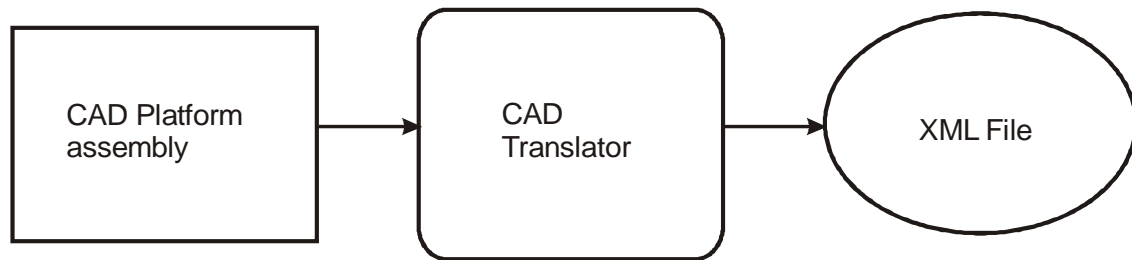

**Figure 6: Exporting from CAD to XML**

Then converting the Physical Modeling XML file into a SimMechanics model in Simulink.

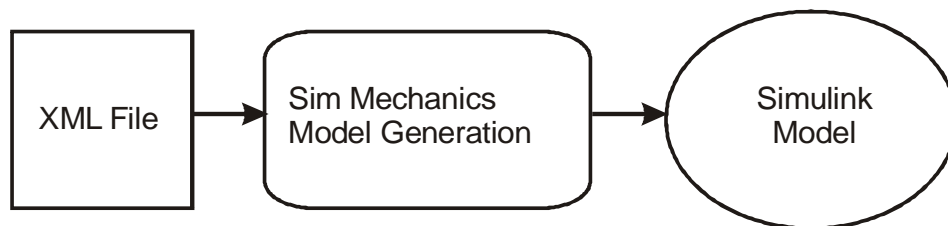

**Figure 7: Convert XML file to SimMechanic model**

SimMechanics is a dynamic environment for simulating body motions. The CAD translator creates a Physical Modeling XML file that represents the assembly parts as bodies and maps the assembly mates into a corresponding set of joints. After that it needs to specify enough information in CAD assembly for SimMechanics to construct a dynamically meaningful model from the XML file.

**Table 2**  
CAD component corresponding Sim Mechanics block

CAD Assembly Component	Corresponding Sim Mechanics Blocks
Part	Body
Mates	Joints
Fundamental Root	Ground – Root Weld – Root Body
Subassembly	Subsystem
Subassembly Root: [[trunk]] – mate(s) – subassembly....	[[ Root Body – Root Weld – Fixed Body ]]- Joint – subsystem....
Fixed Part (in a subassembly)	Root Body – Weld – Body

**(B) Robotic Arm Controller Circuit**

By using CAD translator robotic arm converted into corresponding simulink circuit block in MATLAB/Simulink as shown in below figure.

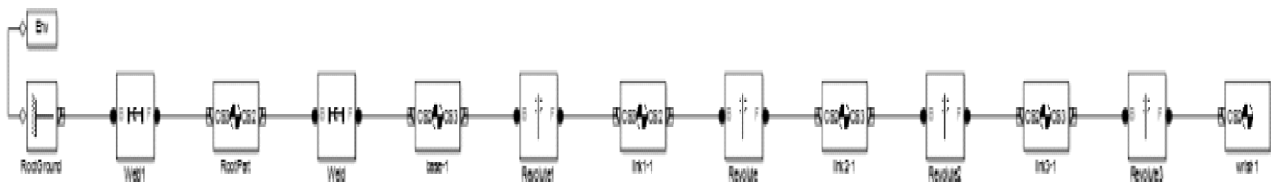

**Figure 8: Basic Simulink model of Robotic arm**

For the movement of the robotic arm a controller block required. So attach the controller blocks and reference blocks to that robotic arm finally connected to scope as shown in below figure.

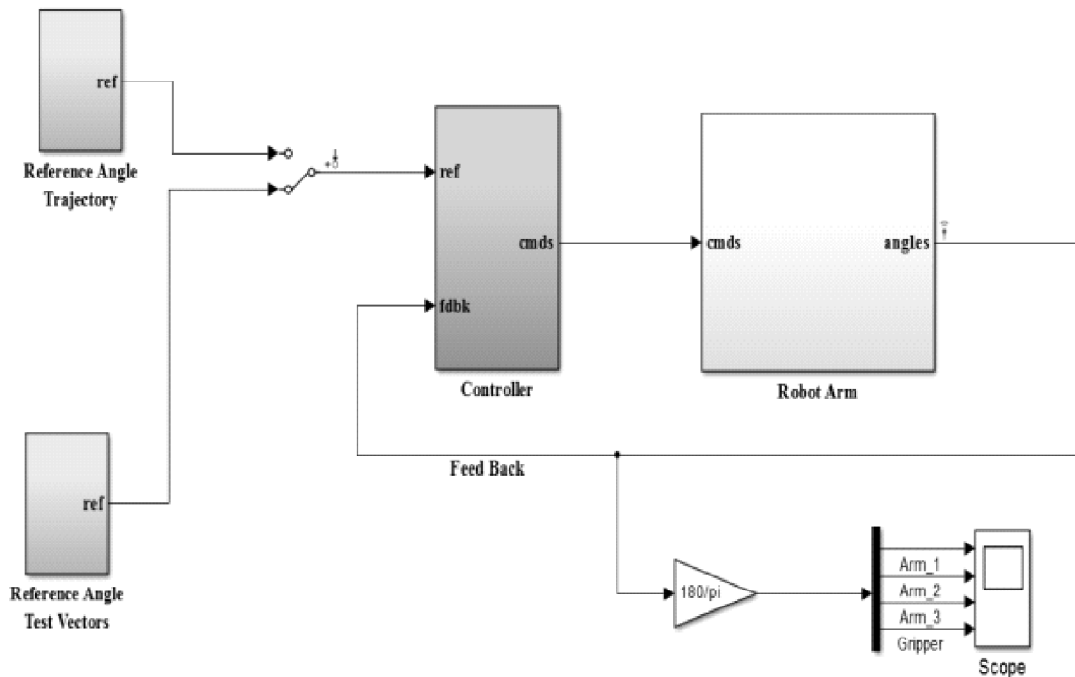

**Figure 9: Circuit model of robotic arm**

The reconstructed robotic arm simulink model as shown in below Fig. 10.

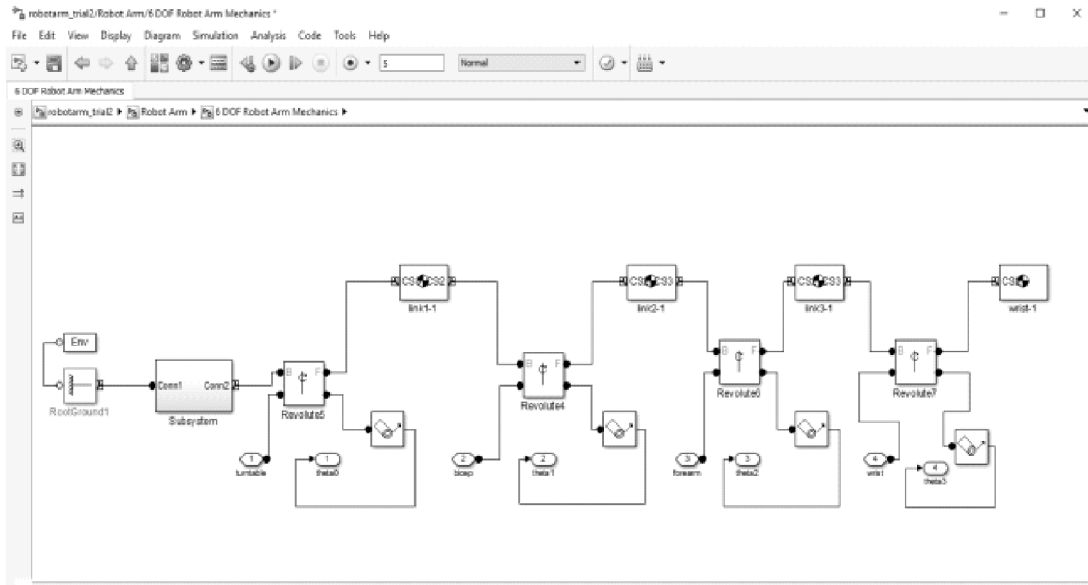

**Figure 10: Simulink model of Robotic arm**

In this circuit model contains reference angle trajectory, reference angle test vector, controller, robotic arm blocks and finally scope are presented. In this reference angle trajectory, reference angle test vector block are used to given the joint angles to the robotic arm. Controller block controls the dc motors present in the robotic arm for this purpose we use PID (Proportional Integrate Derivative) controllers. In this PID controller gives an error of  $\pm 30$  error (Joint angle error). Based on that robotic arm moves and are as shown in following below Fig. 11 to Fig. 14.

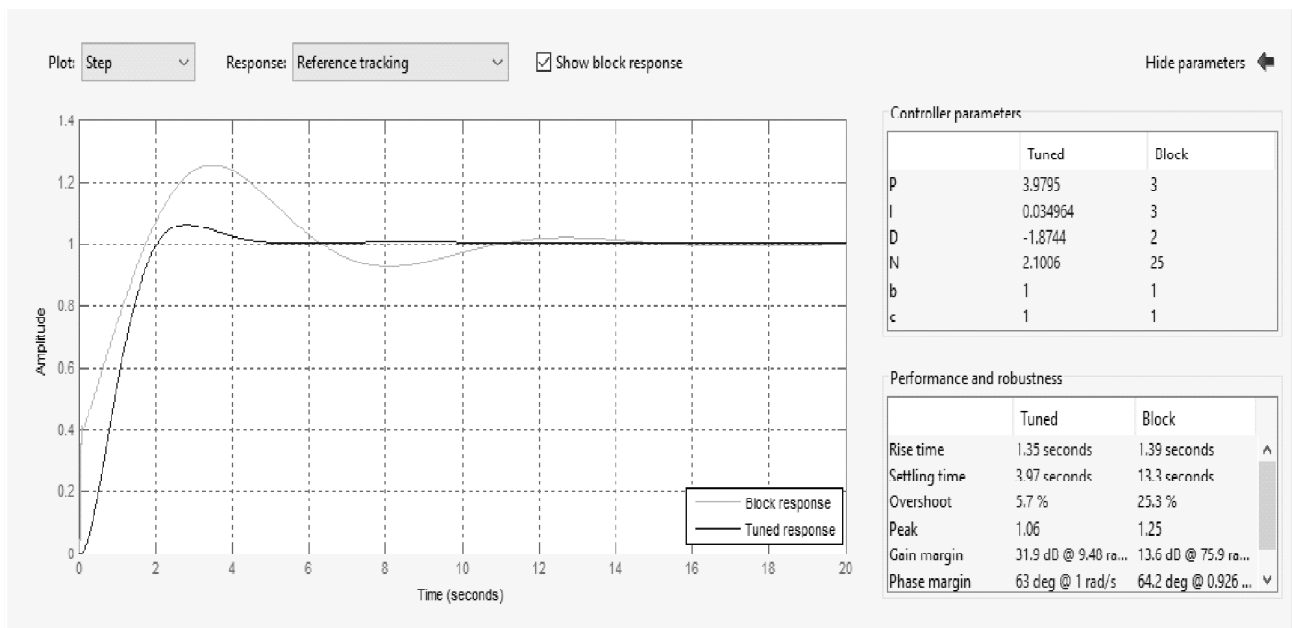

**Figure 11: Reference tracking**



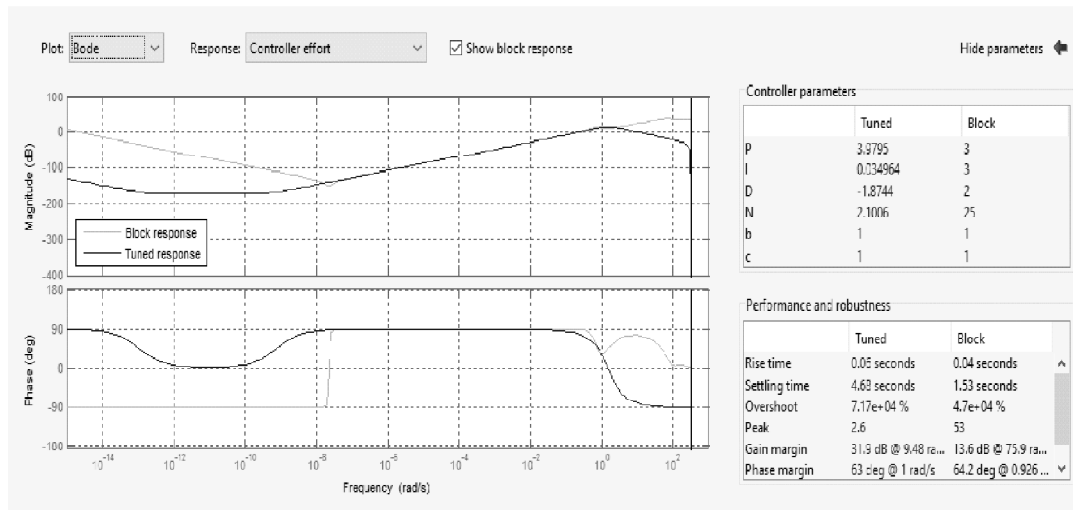

Figure 12: Controller effort

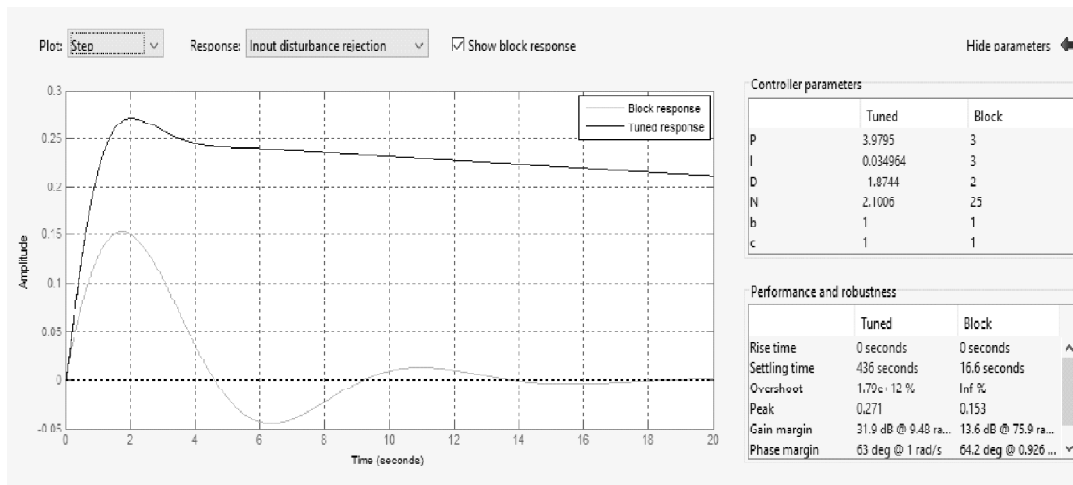

Figure 13: Input disturbance rejection

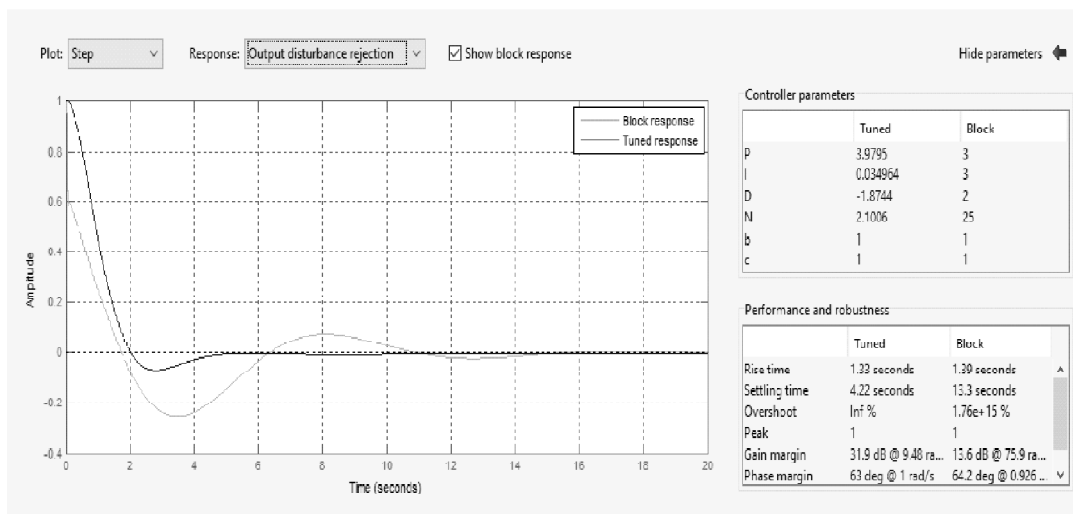
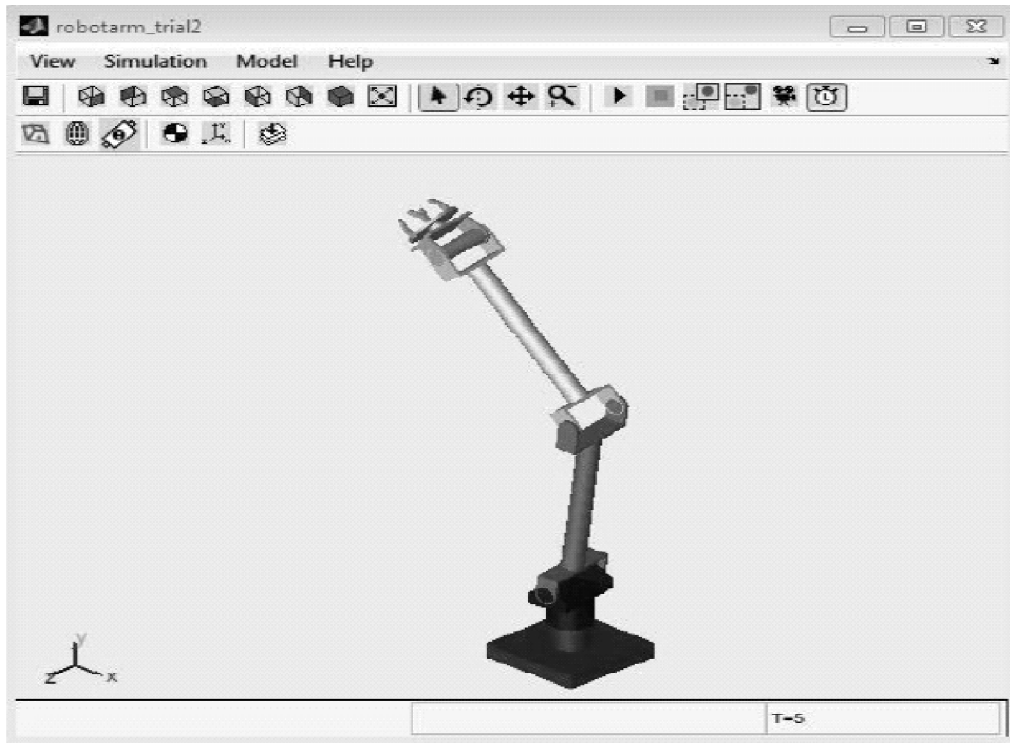

Figure 14: Output disturbance rejection

#### 4. RESULTS

Robots have gotten to be imperative over an extensive variety of uses - from assembling, to surgery, to the treatment of risky materials. Subsequently, it's imperative to see how they function, and what issues exist in planning powerful robots. This paper tended to one of those issues like pick and place of an object.



**Figure 15: Robotic arm in simulation**

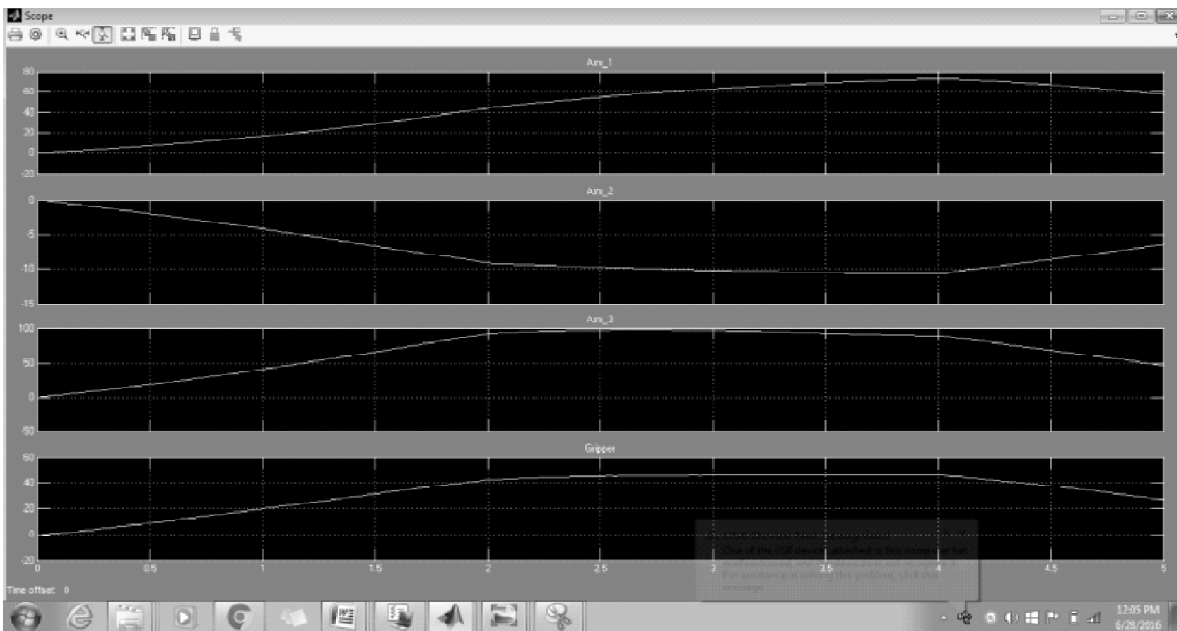

**Figure 16: Simulation result waveforms of robotic arm**

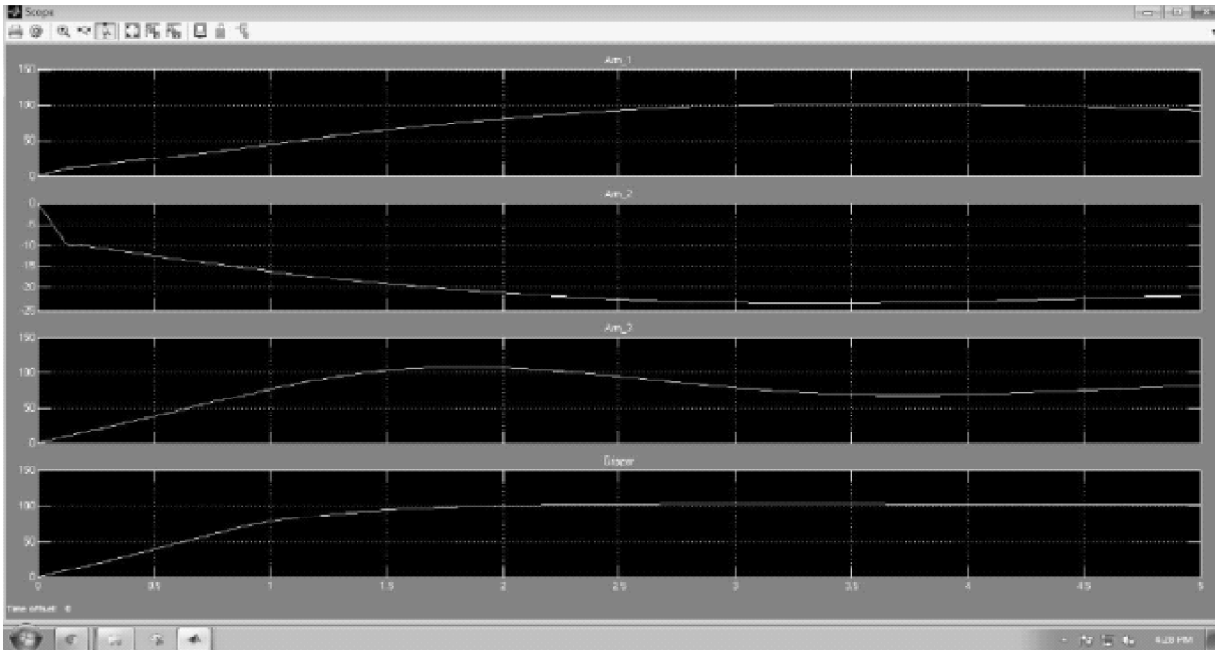

**Figure 17: Simulation result waveforms of robotic arm**

The design of 3R revolute type 6 DoF arm was designed and simulated, and results are shown in the above Fig. 17. Simulation results of the Arm\_1, Arm\_2, Arm\_3 and gripper rotates with respective given angles as per the design. These angles are taken from the applied kinematics to robotic arm for the simulation purpose. Simulation results shows a small error of  $\pm 30$ , while arm is moving because PID controllers have some noise.

## 5. CONCLUSION

The 3R robotic arm is designed in solidworks based on PUMA robotic arm (also known as serial manipulator) and designed arm is exported to Matlab/Simulink for the simulation. The designed arm had three prismatic joints and six degree of freedom, it means each joint is having two degree of freedom those are Roll and Yaw movements. It can move the object from one place to another place and each joint rotates as per applied kinematics. These angles are used to move the robotic arm but there is a small error while arm is moving because PID controllers which are used have noise. It's possible to reduce this error by using servo motors to get perfect movement in MATLAB/Simulink.

## REFERENCES

- [1] Brahim Fernini “Kinematic Modeling and Simulation of a 2-R Robot by Using Solid Works and Verification by MATLAB/ Simulink”, International Journal of Robotics and Automation (IJRA), (2012), Vol.
- [2] Mohammed Z. Al-Faiz, Abduladhem A. Ali and Lec. Abbas H.Miry “Human Arm Simulation Based On Matlab With Virtual Enviroment”, IJCCCE, VOL.11, (2011).
- [3] Vincenzo Lippiello and Fabio Ruggiero “Exploiting Redundancy in Cartesian Impedance Control of UAVs Equipped with a Robotic Arm”, International Conference on Intelligent Robots and Systems,(IEEE/RSJ), (2012).
- [4] Brahim fernini and mustapha temmar, “An Algorithm For Serial Planar Manipulators That Have An Architecture R/(n)R By Using Solidworks (2013) and Matlab/Simulink (2012)”, International Conference on Mechatronics and Automation, (2013).
- [5] F. Ruggiero, M.A. Trujillo, R. Cano and H. Ascorbe “A multilayer control for multirotor UAVs equipped with a servo robot arm”, IEEE International Conference on Robotics and Automation (ICRA), (2015).

- [6] Wen-Bo Li, Guang-Zhong Cao, Xiao-Qin Guo and Su-Dan Huang, “Development of a 4-DOF SCARA Robot with 3RIP for Pick-and-Place Tasks”, (2015).
- [7] Ciprian-Radu Rad and Sergiu-Dan Stan, “Forward Kinematics and Workspace Analysis of a 3-RPS Medical Parallel Robot”,(2012).
- [8] Farhan A. Salem, “ Modeling, Simulation and Control Issues for a Robot ARM; Education and Research”,I.J. Intelligent Systems and Applications, (2014).
- [9] Muhammad Majid Gulzar, Ali Faisal Murtaza, Qiang Ling and Muhammad Yaqoob Javed, “Kinematic Modeling and Simulation of an SCARA Manipulator by Pro-E and Verification using MATLAB/Simulink”, International Conference on Open Source Systems and Technologies (ICOSST),(2015).
- [10] Weiyuan Xu, Yangmin Li, Senior Member and Xiao Xiao, “Kinematics and Workspace Analysis for a Novel 6-PSS Parallel Manipulator”, International Conference on Robotics and Biomimetics (ROBIO), (2013).
- [11] Wen Guojun Xu Linhong He Fulun, “Offline Kinematics Simulation of 6-DOF Welding Robot”, International Conference on Measuring Technology and Mechatronics Automation, (2009)
- [12] Sudharsan.J and Karoonmurthy.L, “Path Planning and Co-Simulation Control of 8 DoF Anthropomorphic Robotic Arm”, ISSN 1726-4529, (2016).
- [13] Chao Liao, Jianbin Zhang, Weihai Chen, Mingxing Lv, “Union Simulation on Lower Limbs Rehabilitation Robot Based on MATLAB and ADAMS”, IEEE, (2015).
- [14] Xiao Xiao, Yangmin Li and Hui Tang, “Kinematics and Interactive Simulation System Modeling for Robot Manipulators”, IEEE International Conference on Information and Automation, (2013).