

Evaluate and Detection of Ambulatory Stress Event for Real-time Drivers using wearable wireless vital Signs

J. Sudhakar* and S. Srinivasan**

ABSTRACT

The experience of daily stresses among the drivers and psychological health, and can impact driving behavior and overall road safety. Although previous research consistently supports these findings. Small attention has been dedicated to the design of stress detection methods able to synchronize physiological and psychological stress response of drivers in their day-to-day routine work. To overcome these limitations, we propose analysis and detection of real-time driver's stress response and facilitate memory recall of the stressful situations. We use sensors to monitor the activity of the driver. Drivers stress condition also monitored for safety check. Through safety check, we can avoid accident by intimating driver about danger. In our system provides real world visual cues and information, which seems to facilitate driver Memory retrieval, Enriching description of stressful events, and findings provide contextualized sources of stress within a city.. The enriching findings suggest that our system can be a promising tool to support applied occupational health interventions for public drivers and future guide authorities

Keywords: Drivers ambulatory stress detection, Heart beat monitoring, Features extraction and Evaluation, Physiological recognition.

1. INTRODUCTION

The development of future transportation systems required a continuous assessment of driving state, including vehicle, road and driver state, where the latter is considered the most important when considering various conditions controlling the physiology of human body. Stress occurring during driving has been linked to some effects as impaired decision making capabilities, decreased performance and degraded situation awareness [1]. Therefore, the early detection of this situation is necessary to improve drivers awareness and performance, which are important for road and traffic safety [2]. stress monitoring systems have been developed to notify driver risk condition which is based on the degree of stress during real driving [4][5]. The importance of this evaluation of driver task has been increased with the increasing usage of on board electronics and in-vehicle information system by multiple fields [3][9]. In order to detect this physiological condition many methods have been used like eye glance and on-road metrics, but these methods have been criticized as very costly and difficult to obtain [4][12]. In the other hand, validated as an effective way to detect different physiological conditions.

2. LITERATURE SURVEY

In order to detect this physiological condition many methods have been used like eye glance and on-road metrics, but these methods have been criticized as very costly and difficult to obtain [4]. Therefore, we can define stress events as physiological re-actions of the driver to driving events. It has been noticed that when

* Research Scholar, Department of Communication & Engineering, St. Peters University, Avadi, Chennai, India, Email: sudhak1241@gmail.com

** Research Supervisor, Department of communication Engineering, P.B. Engineering college, irungatukottai, Chennai, India, Email: srinivasan.me.03.@gmail.com

subjects experience stress events, they have specific reactions mapped to their physiological signals, like an increase in heart rate and skin conductivity [6]. It has been noticed that when subjects experience stress events, they have specific reactions mapped to their physiological signals, like an increase in heart rate and skin conductivity. Thus, the detection of stress events is possible through monitoring of the driver's physiological reactions to driving events [3],[10]. The autonomic nervous system (ANS) is decomposed into sympathetic nervous system (SNS) and para sympathetic nervous system (PSNS) components. The imbalance between these two systems can be an indicator of physiological variation reflected in HRV measurements. The latter are resulted from various problem domains such as: (1) (ANS) function evaluation of chronic diseases with different severity levels [8] and (2) physiological conditions recognition such as stress, depression and emotion recognition. In this work, we examine different analysis of HRV in time [5], frequency, nonlinear and time-frequency domains in order to identify the best parameters that vary between two levels of driver's stress low and high during a real-on-road driving environment, using a feature extraction method and a classification technique to give the best classification accuracy, and then validate the role of HRV as a stress biomarker [11]. A limited number of approaches have been presented during the last years for driver stress monitoring.

SYSTEM MODEL

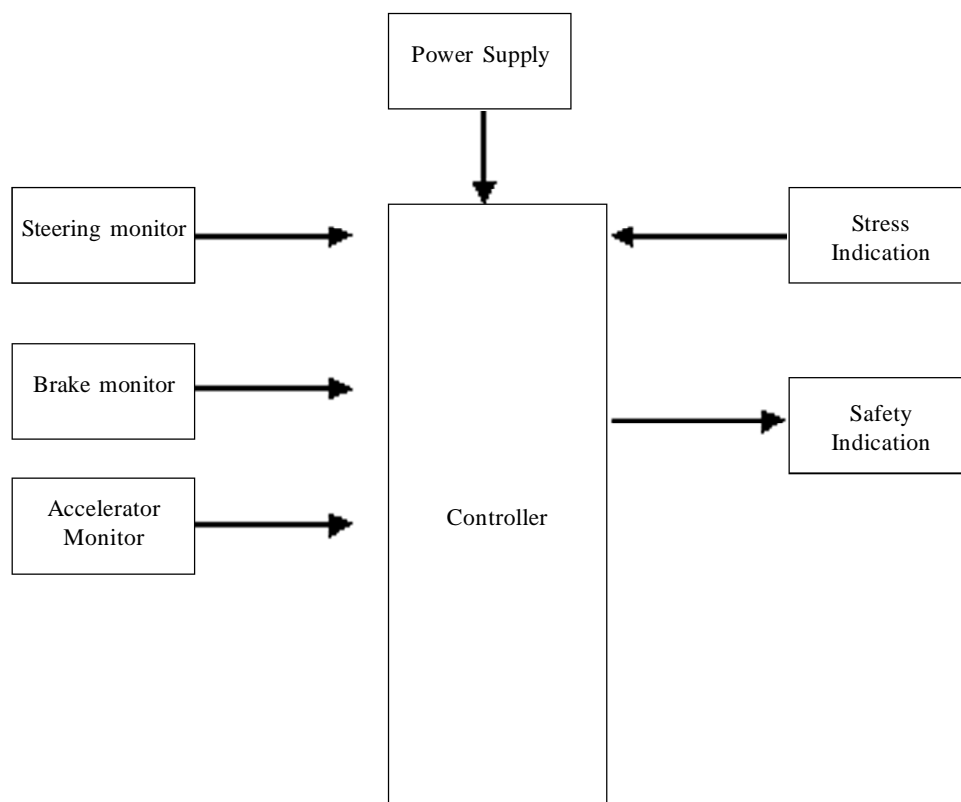

Figure 1: Block diagram

3. HARDWARE DESCRIPTION

3.1. DC Motor

This kit allows controlling the speed of a DC motor in both the forward and reverse direction. The input +5v DC power supply given to the circuit. The range of control is from fully OFF to fully ON in both directions. Normally, switches are used to change the direction of rotation of a DC motor. Change the polarity of the applied. Voltage and motor spins the other way. A GSM Modem is connected to each Telecontrol unit. The central server calls up each of the Telecontrol units in samples to pick up the data stored in that.

3.2. Heart Beat Sensor

Heart beat sensor is designed to give digital output of heart beat when a finger is placed on it. When the heart beat detector is working, the beat LED flashes in unison with each heartbeat. This digital output can be connected to microcontroller directly to measure the beats per minute (BPM) rate. It works on the principle of light modulation by blood flow through finger at each pulse. A liquid crystal display is a thin, flat display device made up of any number of color or monochrome pixels arrayed in front of a light source or reflector. It is often utilized in battery-powered electronic devices because it uses very small amounts of electric power.

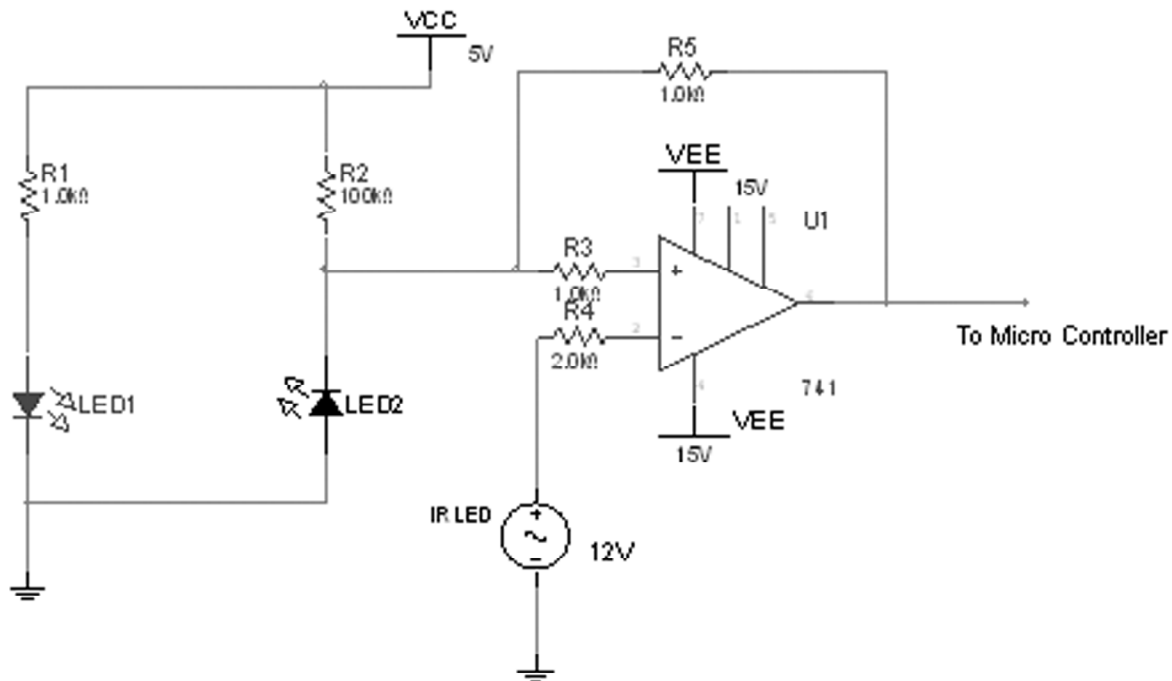

Figure 2: Heart Beat Sensor Circuit Diagram

3.3. PIC Microcontroller

All of the devices in the PIC18FE455/2550/4455/4550 Family incorporate a range of features that can significantly reduce power consumption during operation. by clocking the controller from the timer 1 source or the internal oscillator block .power consumption during code execute on can be reduced by as much as 90%.in multiple mode, the controller can also run with its CPU core disabled but the peripherals still active in these states.

4. RESULT AND DISCUSSION

4.1. Experimental setup

Our experimentation are applied to the sensor consist of a super bright red LED needs to be super bright as the maximum light must pass spread in finger and detected by detector. Now, when the heart pumps a pulse of blood through the blood vessels the finger becomes slightly more opaque and less light reached the detector. With each heart pulse the detector signals various. This variation is converted to electrical pulse. This signal is amplified and triggered through an amplifier which outputs +5v logical level signal. The output signal is also indicated by aL which blink the heart Rate and connected regulated DC power supply of 5 Volts. Black wire is Ground, Next middle wire is Brown which is output and Red wire is positive supply. These wires are also marked on PCB. We can leave the output wire as it is. When Beat LED is off the output is at 0V. Put finger on the marked position, and you can view the beat LED blinking on each heartbeat.

Black wire is Ground, Next middle wire is Brown which is output and Red wire is positive supply. These wires are also marked on PCB.

We can leave the output wire as it is. When Beat LED is off the output is at 0V. Put finger on the marked position, and you can view the beat LED blinking on each heartbeat

The output is active high for each beat and can be given directly to microcontroller for interfacing applications. Our experimentation results suggest finding the heart beat level regardless of the physiological driving conditions in various stress level.

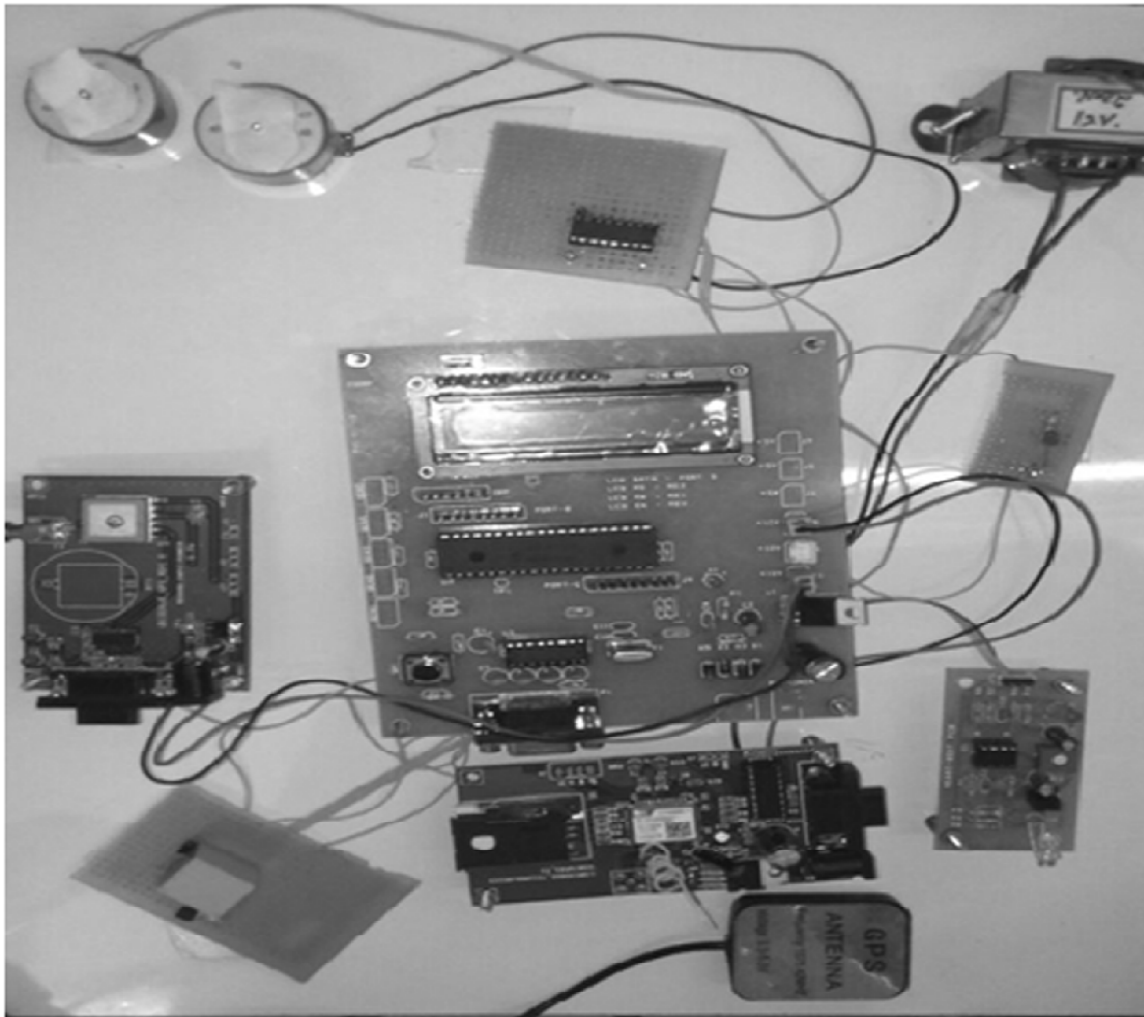

Figure 3: Experimental setup

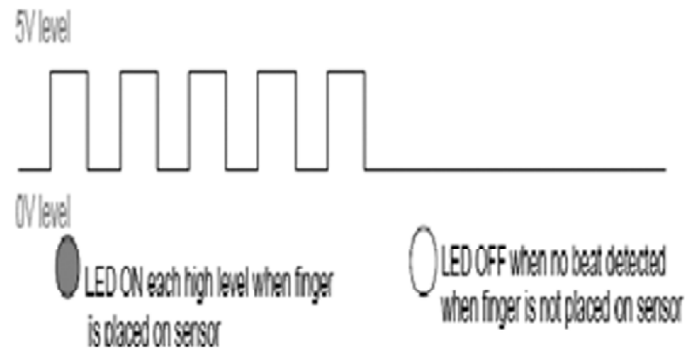

Figure 4: Heart beat output signal

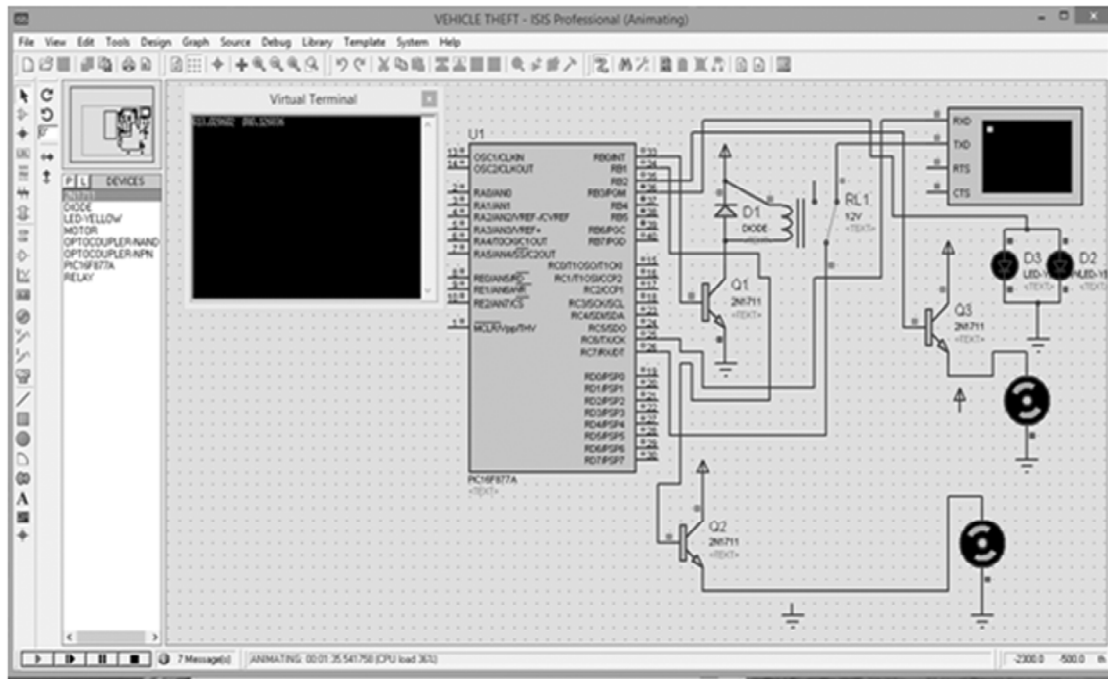

Figure 5: Circuit Connection Diagram

4.2. Result

Stress Detection Performance of various Physiological conditions of drivers

S. No	Various physiological Condition for drivers	Heart beats (BPM)	Stress detection Level
1	Normal	72	Normal
2	Drowsy	75-85	Low
3	Diabetics /hypertension	85-95	Medium
4	Drunk & drive	>90	High
5	Coronary deficiency (Heart attack)	>100	Very high

5. CONCLUSION

In this paper, we have demonstrated the identification of differ physiological states of automated driver under various conditions using Heart beat level. The stress detection of final data should collect in various abnormal conditions of drivers and the result plot in Table. The stress level also varied depends upon the condition of the drivers. In urban area allows predicting stress level of the driver which will ensure the to provide better security for automotive drivers in order to avoid and identify the automotive drivers in different physiological conditions. Our experimentation results suggest finding the heart beat level regardless of the physiological driving conditions in various stress level. In future work, it is suggested differ driver stress using more samples in real time manner and identifying significant parameters to realize the purpose.

REFERENCE

- [1] J.S. Wang, W.C. Lin, and Y.T.C. Yang, "A k-nearest-neighbor classifier with heart rate Variability feature Based transformation algorithm for driving stress Recognition", *Neurocomputing*, vol. 116, pp. 136-143, Sep. 2013.
- [2] I.V. Uppanlawarand H. Chowhan, "Pre-processing of ECG Signals Using Filters" vol. 11, No. 4, pp. 166-168, 2014.
- [3] N. Debbabi, U.P. and S. Com, "Correction of ECG baseline wanders Application to the Pan Tompkins QR Detection Algorithm", pp. 2014.
- [4] Syed Rizwan Basha, R. Monohari, "ECG and Driver monitoring system based on Wireless Transceiver", *International Journal of Scientific & engineering Research*, volume 4, issue 5, May-2013.

-
- [5] J.P.S Cunha, “*P Health* and wearable Technologies: A permanent challenge”, *stud. Health Technology. Inform*, vol. 177, pp. 185-195, 2012.
 - [6] Ji Hyun Yang and Hyen Bin Jeong, “Improvement of Drivers-state estimation Algorithm using multi-model Information”, 15th international conference on *control, automation and systems*, Oct. 2015.
 - [7] George Rigas, and Yorgos Goletsis, “Real-Time Driver’s Stress Event Detection”, *IEEE Transactions on intelligent Transportation systems*, vol. 13, no. 13, no. 1. March 2012.
 - [8] Jao G.P. Rodrigues and Joao P. Silva Cunha, “A Mobile Sensing blink Bus Drivers”, *IEEE Transactions on intelligent transportation systems Approach to Stress Detection and Memory Activation* for pu1524-9050, 2015
 - [9] D. Sowmya, I. Suneetha and N. Pusphalatha, “Driver Behavior Monitoring through Sensors and Tracking the accident using wireless technology”, *International journal of computer application*, vol. 102, no. 2. Sep. 2014.
 - [10] P. Sarang, P. Suryawanshi, B. Somani and V. Shete, “Analysis of Driver’s Skills from Passenger’s Comfort”, *international journal of advanced Research in computer and communication Engineering*, vol. 4. Issue 6, June 2014.
 - [11] Mamidikirankumar and V. Kamashi Prasad, “Driver Behavior Analysis and Prediction models: A Survey”, *international journal of computer science and information Technologies*, vol. 6, 2015.
 - [12] Hang-Bong kang, “Various Approaches for driver and Driving Behavior Monitoring: A Review”, *IEEE Explore, ICCV* 2013.