



## International Journal of Control Theory and Applications

ISSN : 0974-5572

© International Science Press

Volume 9 • Number 46 • 2016

### Denoising of ECG using Adaptive Filter Algorithm

Ravina Bhati<sup>a</sup>, Supriya Goel<sup>b</sup>, Gurjit Kaur<sup>c</sup> and Pradeep Tomar<sup>d</sup>

<sup>a-d</sup>School of Information and Communication Technology, Gautam Buddha University, Greater Noida, Uttar Pradesh, India. Email: <sup>a</sup>ravina.bhati1@gmail.com

**Abstract:** To detect the abnormalities in cardiac functions, ECG signals are found to be most importance. Power line obstruction, extraneous electromagnetic fields, accidental body actions and exhalation and inhalation process are some artifacts or unwanted noises which affect the ECG data. There are several methods which are implemented to abolish signal ingredients from nonessential frequency dimension. As human behavior cannot be known exactly with time, so digital filters are very difficult to apply to reduce biomedical signal noises due to fixed coefficients. In this research, Adaptive filter is implemented so we can clean the electrocardiogram biosignals from the abolish noise by exercise Least Mean Square or LMS adaptive algorithm and the results obtained presented with the help of lab VIEW. Performance of Adaptive filter is also checked with the help of learning curves.

**Keywords:** ECG, EMG, Power line interface, Adaptive filters, Adaptive algorithm LMS, Wavelet Transform.

#### 1. INTRODUCTION

Heart diseases can be diagnosed by monitoring cardiac activities and cardiac activities are best monitored by Electrocardiogram (ECG) which displays the cardiac activities in graphical form. ECG signals are found most important to detect the abnormalities of cardiac functions. ECG signals may get contaminated with several noises while recording. Noises such as power line interface, extraneous electromagnetic fields, accidental body actions and exhalation inhalation process. The motive with this technique is to separate these noises from the ECG signals in order to commence a result which helps an clear and authentic analysis.

P wave in Figure 1 shows the Atrial depolarization. The Q, R and S waves together make up QRS complex, which speak for the ventricular depolarization whereas T wave shows the ventricular repolarization. The interval defined between S wave and the beginning of the T wave is termed as the ST segment.

Different believed and important mechanism to abolish artifacts like power line intrusion is notch filter, it adjust itself into the prevalence of intrusion in signal. The complication in finite impulse response (FIR) notch filter is the notch has a somewhat enormous bandwidth that reduces the required signal ingredients not outside the bandwidth [1, 2].

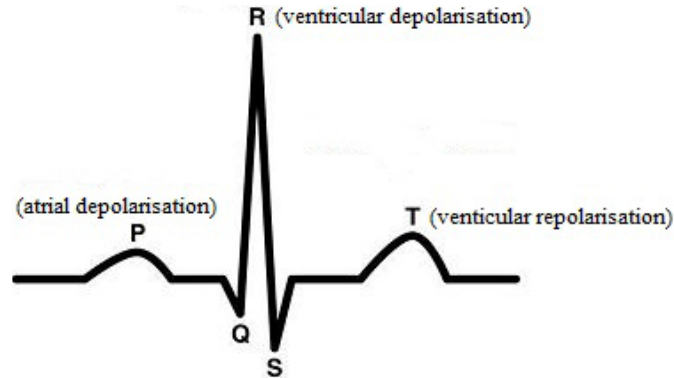

Figure 1: ECG Waveform

Enlarged Kalman filters [3], a mean shift algorithm [4], state vectors with time lag [5], and experimental mode disintegration (EMD) [6, 7] are the different design approaches. Generally, the previous algorithms are used where the biosignal is tarnished and noised either by white noise or other types of noises separately but the effect of mixed noise on the signal is not noticed and not all external noises are admitted. Many more methods have been submitted for the study of ECG improvement practicing the two adaptive and non-adaptive approach [8], adaptive filtering techniques allows the detection of potentials which vary with time and also notice the difference in conditions of the biosignals. The most simple and user friendly algorithm among all adaptive filter algorithms is least means square or we can say LMS due to its ease ways to compute the results. It was bringing into use for first time by Widrow and Hoff in 1959 [9-10]. Morlet was the first one who bought the theory of wavelet transform in 1984 which helps us in deals with geophysical data as it provides number of possible basis functions due to variation in the windows. Research is further formulated in different sections. First we will discuss about the Adaptive Filter and its Algorithm in second we will show the system design and in last we will analyze the practical results of ECG denoising using adaptive filter.

## 2. ADAPTIVE FILTER

Adaptive Filter is a technique or process which helps us in removal or filter unwanted components or features from the signals. This filter is controlled by some parameters which are adjusted according to the adaptive algorithm. As the name shows, it is the algorithm which adapts itself or we can say it changes its behavior according the available resources or available information during the running time. In the below figure Linear Filter are of two different types that is finite impulse response (FIR) and infinite impulse response (IIR).

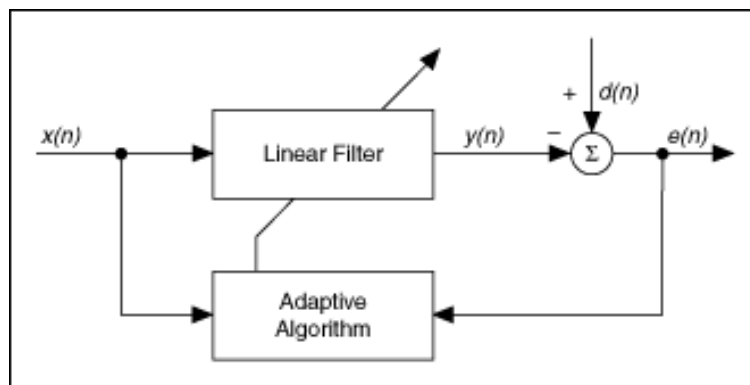

Figure 2: Adaptive Filter

There are several types of Adaptive Filters Algorithms that are used to filter signal. Least Mean Square (LMS) is the commonly using algorithm in filtering because of its computation complexity. As in this algorithm, flow evaluation is done. Normalized LMS(N-LMS) is used when the concurrence speed of LMS algorithm is heightened without bearing more calculation, then normalized LMS algorithm, a alternative of LMS algorithm is oppressed.

This algorithm shows best achievement when operating in time changeable climate. In this paper we will use Least Mean Square Algorithm. The process of LMS algorithm includes that it accommodate the coefficients of FIR linear filter to curtail the power of  $e(n)$ . This process can be explained as follows:

**Step 1:** Output Signal  $y(n)$  shown in the figure above can be calculated with the help of below equation.

$$y(n) = \bar{u}^T(n) \cdot \bar{w}(n) \quad (1)$$

where,  $\bar{u}(n)$  is input vector and can be calculated as:

$$\bar{u}(n) = [x(n)x(n-1) \dots x(n-N+1)]^T \quad (2)$$

and  $\bar{w}(n)$  is coefficient vector and can be calculated as:

$$\bar{w}(n) = [w_0(n)w_1(n) \dots w_{N-1}(n)]^T \quad (3)$$

**Step 2:** Calculate the Error Signal with the help of below equation:

$$e(n) = d(n) - y(n) \quad (4)$$

**Step 3:** After calculating error signal, adaptive algorithm adjusts its filter coefficient of linear filter with the help of below equation:

$$\bar{w}(n+1) = (1 - \mu C) \cdot \bar{w}(n) + \mu \cdot e(n) \cdot \bar{u}(n) \quad (5)$$

where,  $\mu$  = Step Size.

### 3. SYSTEM DESIGN

The working of the system is based on below flow diagram:

Simulated electrocardiographic signals are collected from the MIT-BIH arrhythmia directory in. edf format. To perform denoising of the ECG signal by using Adaptive filter the systematic process done is shown below:

In Figure 4, various lab view functions are used to make the block diagrams which are responsible to separate the unwanted components from the ECG signal and conclude the results.

### 4. RESULTS

Learning curves are implemented to determine the execution of Adaptive filter by concluding the results of convergence speed, steady state error and stability and all these parameters can be observed well with the help of learning curve. Learning curve can be explained as the graph between the Mean Square Error and Time.

In the above figure, it is clear that Mean square error decreases from 2 to IE-6 as the iteration increases when the step size is 0.01 and then Mean square Error becomes stationary after the iteration reaches around 850.

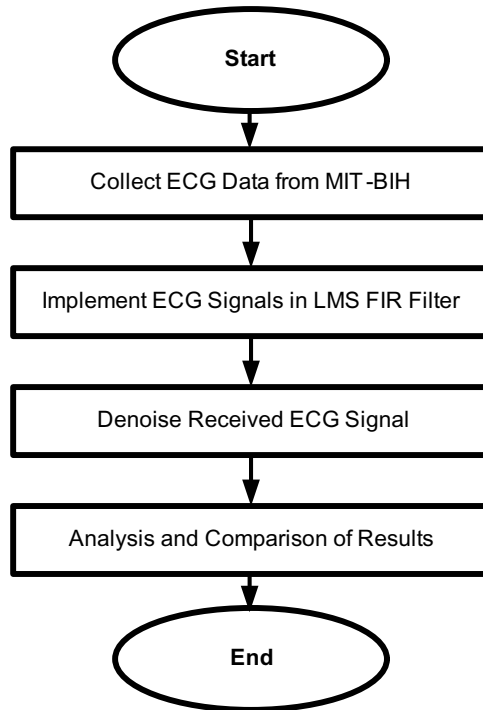

Figure 3: Process of Adaptive Filter Denoising

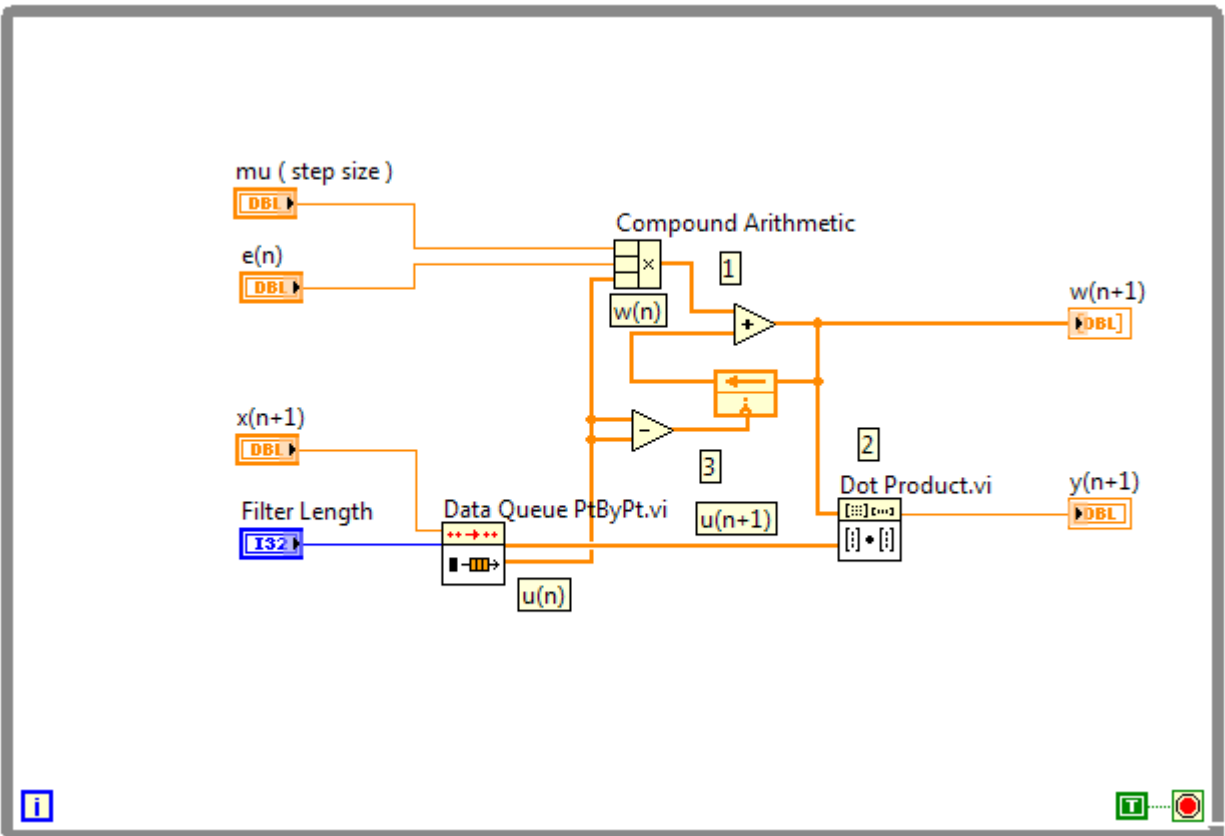
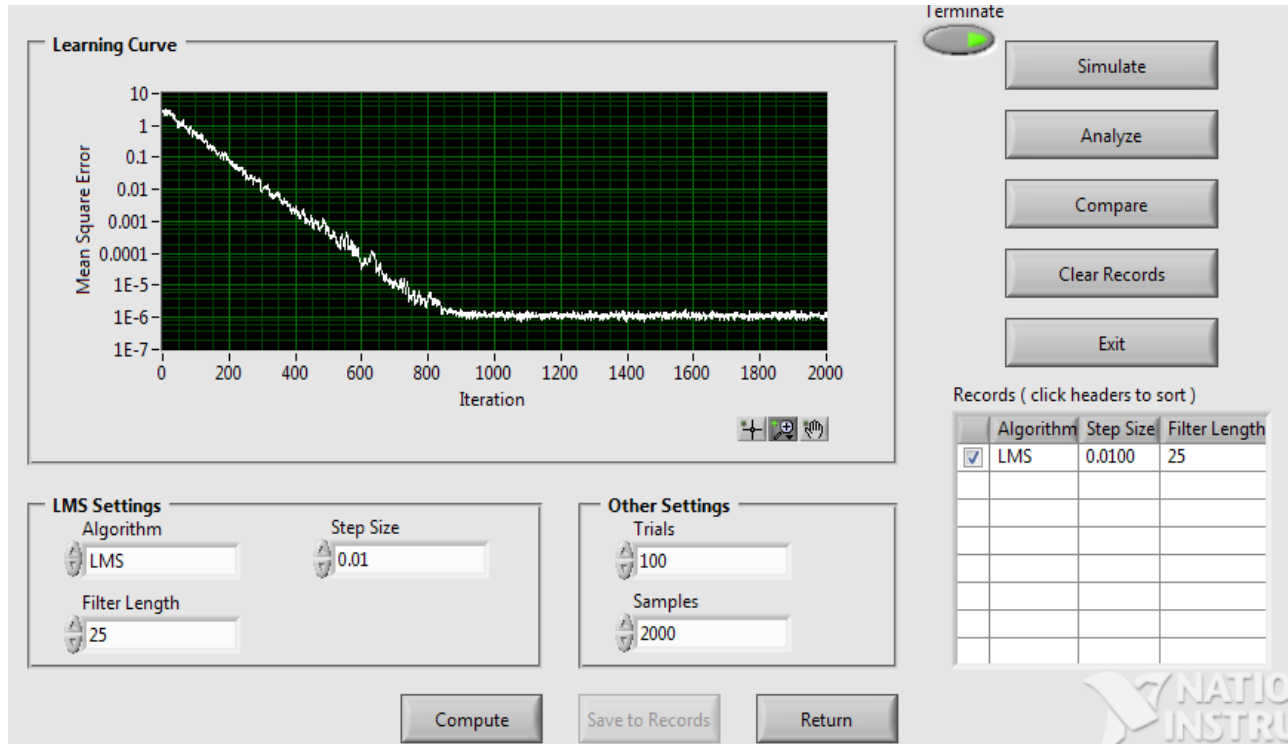
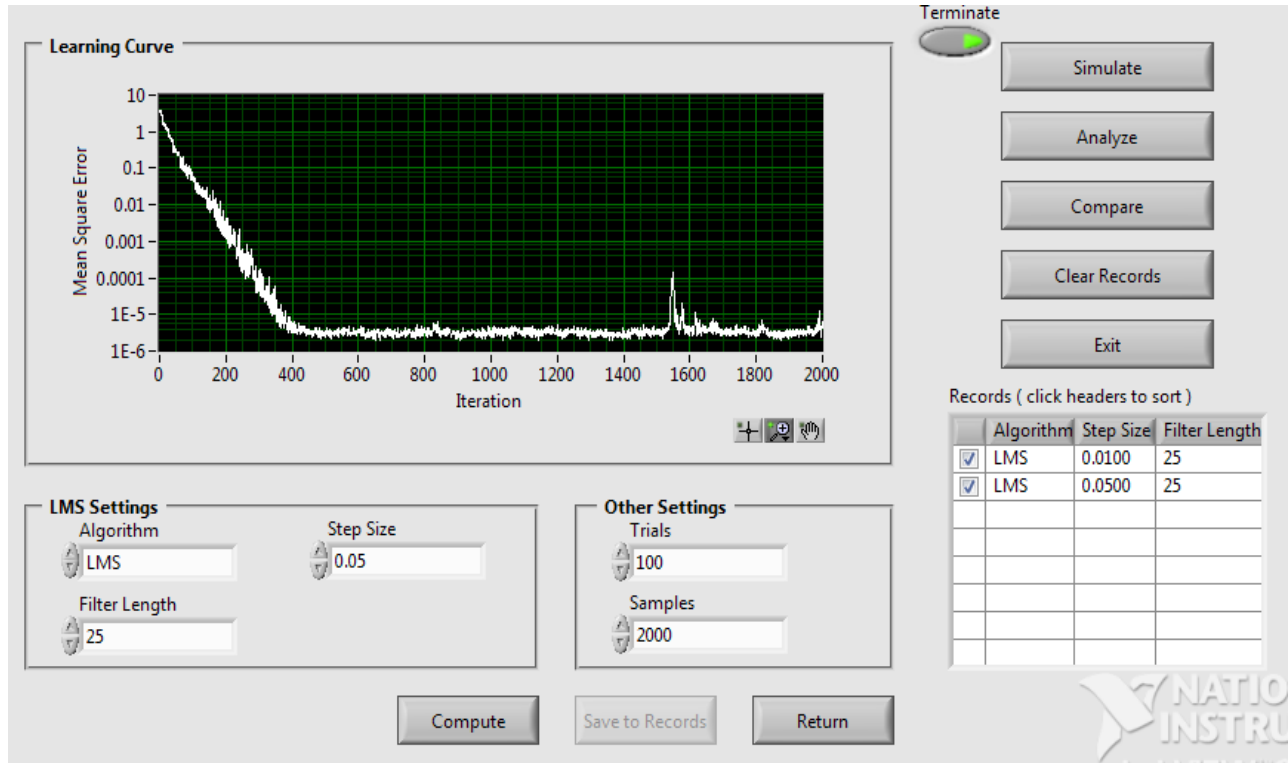

Figure 4: Interconnections of LMS Algorithm



**Figure 5: Adaptive Filter and Error Coefficients to obtain Learning Curves**



**Figure 6: Learning Curve of LMS when step size is 0.01**

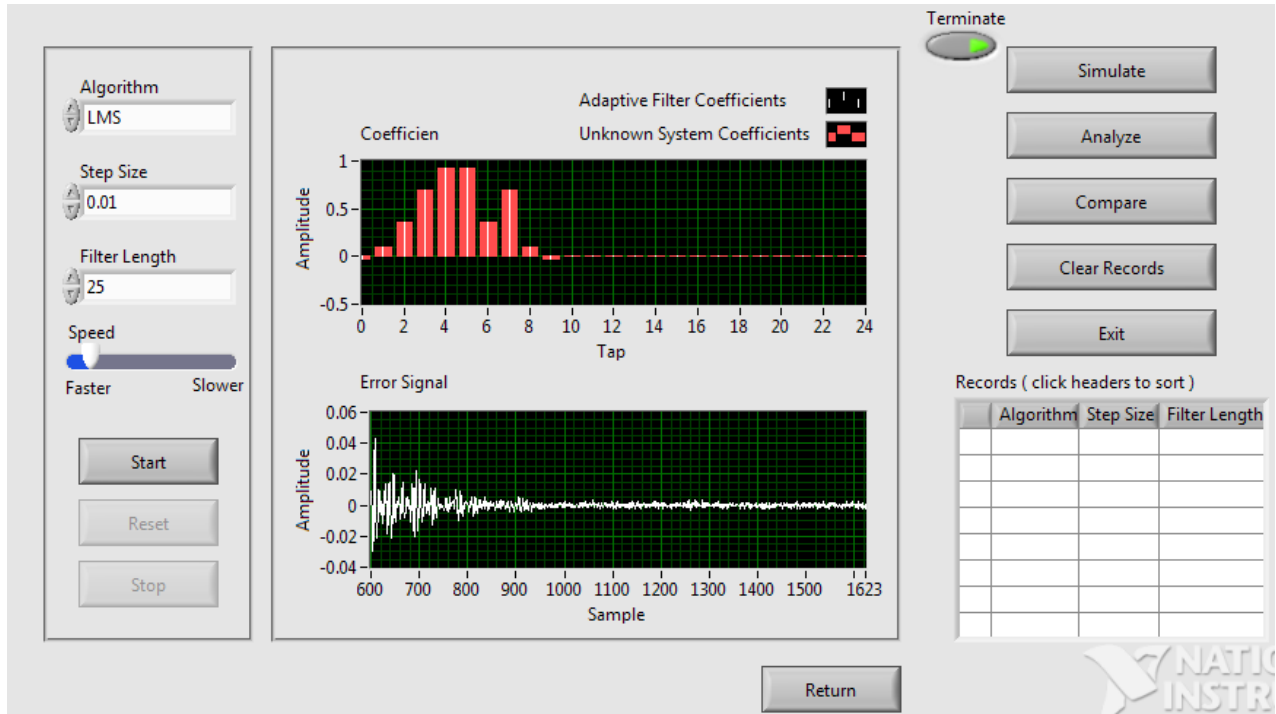

Figure 7: (a) Learning Curve of LMS when step size is 0.05

In the above figure, it is clear that Mean square error decreases from 5 to approximately  $10^{-6}$  as the iteration increases when the step size is 0.05 and then Mean square Error becomes stationary after the iteration reaches around 400.

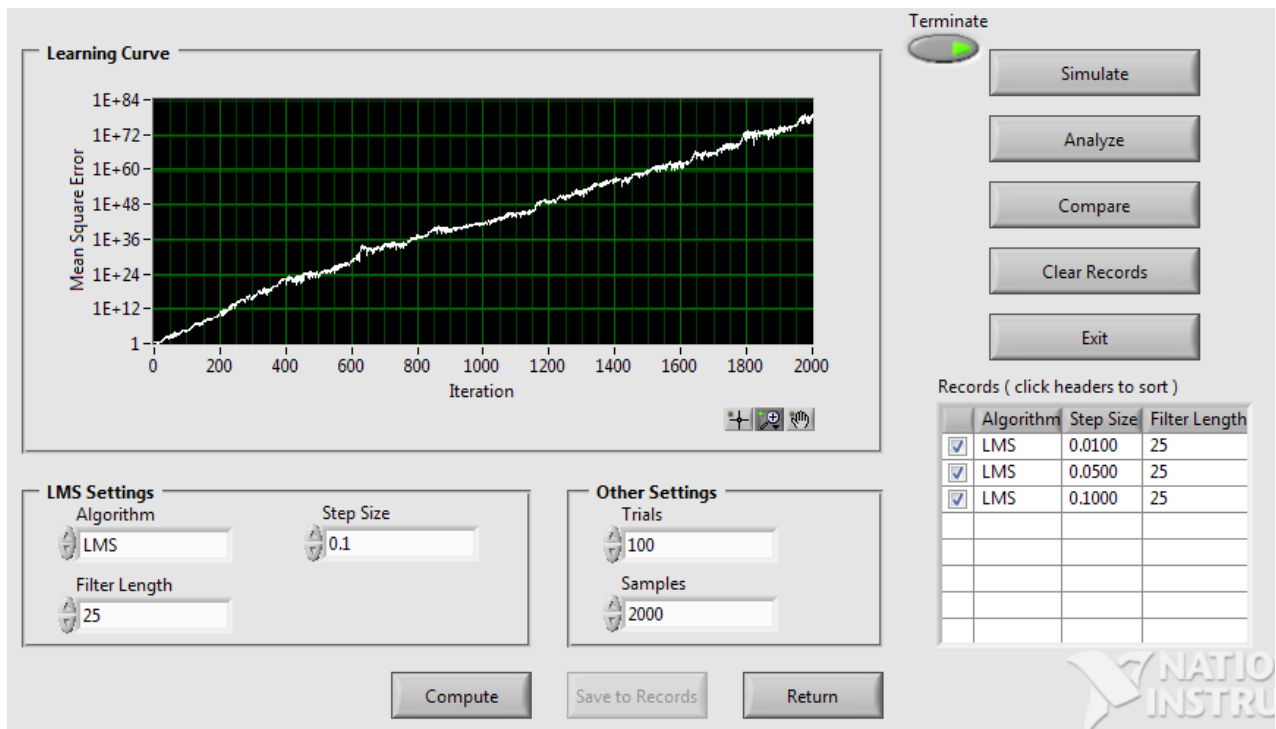
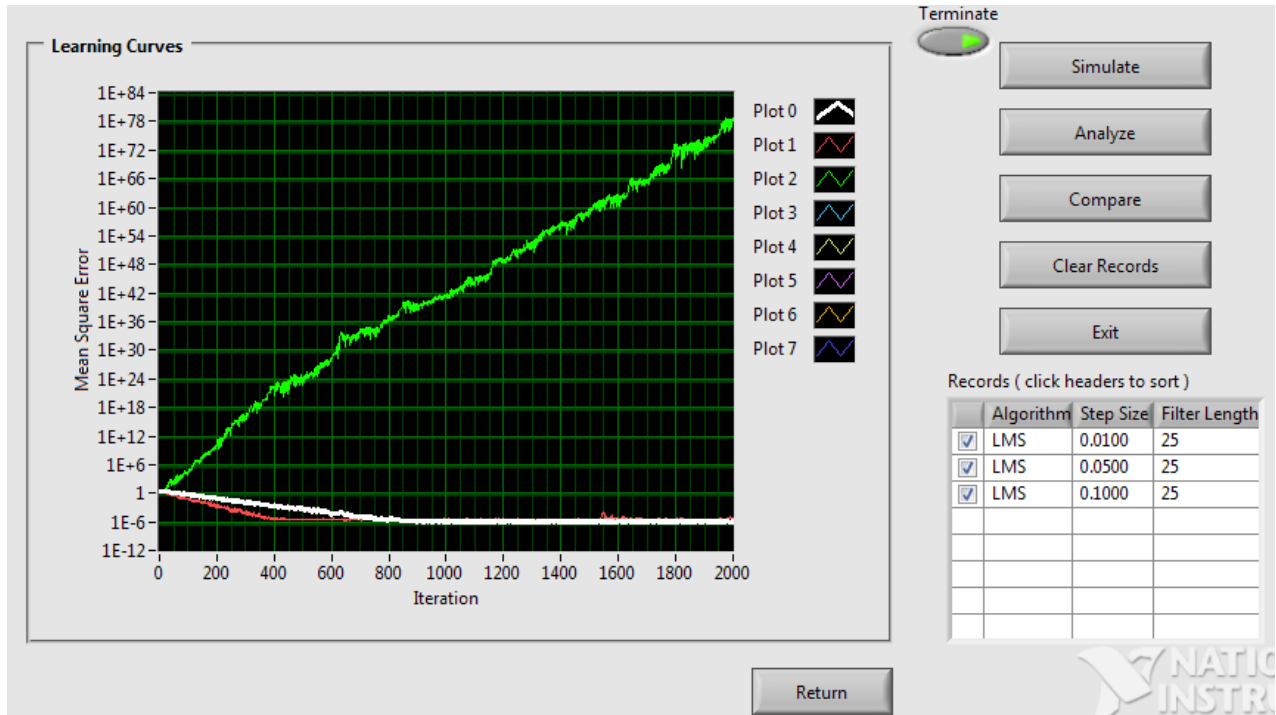

Figure 7: (b) Learning Curve of LMS when step size is 0.10

In the above figure, it is clear that graph between Mean Square Error and Iteration do not get stationary and it keeps on increasing from 1 to IE-72 as the iteration increases when the step size is 0.1.



**Figure 8: Comparison of Learning Curves of LMS**

The above figures shows, as the step size increased by 0.5 the learning curve tends to move towards increasing mean square error rate. By the comparison of above three learning curves, we can conclude that for the same filter length i.e. 25 and for the same Adaptive algorithm i.e. LMS, MSE decreases with iteration and then becomes stationary for the step size 0.010 and 0.050 but for the step size 0.10, MSE keeps on increasing from 1 to IE-72 as the iteration increases.

Results of Adaptive Filter after simulation are shown below in the form of waveform graphs:

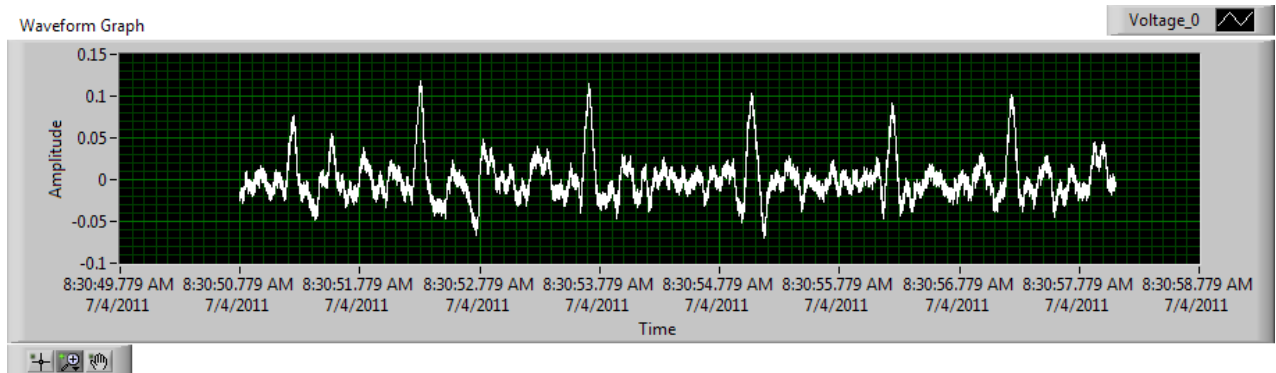

**Figure 9: Noised ECG Signal**

It is very clearly visible in Figure 9 and 10 that ECG curve between Amplitude and Time is more clearly readable and observable in when the signal is denoised as unwanted noise or interference has been removed from the ECG signal and we achieved approximately error less ECG signal.

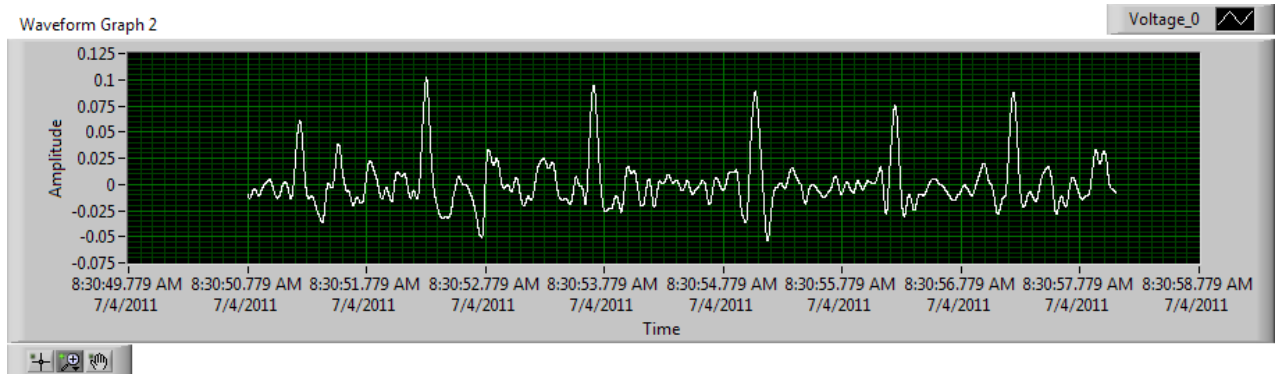

Figure 10: Denoised ECG Signal

## 5. CONCLUSION

The purpose of the work done was to explore the potentialities of adaptive filtering in ECG denoising. It was proved that learning curves between mean square error rate and time shows the performance of Adaptive filter as the value of step size is increasing curve tends towards increasing error rate. The comparison of learning curves on varying values of step size is also showed and concluded that for the same filter length i.e. 25 and for the same Adaptive algorithm i.e. LMS, MSE decreases with iteration and then becomes stationary for the step size 0.010 and 0.050 but for the step size 0.10, MSE keeps on increasing from 1 to  $10^{-72}$  as the iteration increases. The process was implemented in a sequential mode, i.e., first Adaptive filter is designed by using LMS in it, second ECG is inputted in the filter for filtering, third simulation takes place and in last ECG filtered signal is achieved in the denoised manner.

## REFERENCES

- [1] P. Stroch, Single Section Least Square Notch Filter of Adaptive Algorithm, IEEE Transactions on Biomedical Engineering, 43 (8) (1995) 2207-2010.
- [2] M Ferdjalah, R. E. Barr, Digital Notch Filter Design on the Unit Circle for Removal of Power Line Noise From Biomedical Signals, IEEE transactions on Biomedical Engineering, 41(6) (1994) 529-536.
- [3] O. Sayadi, M. Shamsollahi, ECG Denoising and Compression using A Modified Extended Kalman Filter Structure, IEEE Transactions on Biomedical Engineering, 55 (9) (2008) 2240-2248.
- [4] J. Yan, Y. Lu, J. Liu, X. Wu, Y. Xu, Self Adaptive Model Based ECG Denoising Using Features Extracted By Mean Shift Algorithm, Biomedical Signal Process Control, 5 (2010) 103-113.
- [5] H Liang, Z. Lin, F. Yin, Removal of ECG Contamination from Diaphragmatic EMG by Nonlinear Analysis, Nonlinear Anal, (2005) 745-753.
- [6] M. Blancon Velasco, B Weng, K Barner, ECG Signal Denoising And Baseline Wander Correction Based On The Empirical Mode Decomposition, Comput Biol Med (2008) 1-18.
- [7] H. Liang, Q. Lin, J. Chen, Application of The Empirical Mode Decomposition to the Analysis of Esophageal Manometric Data in Gastroesophageal Reflux Diseases IEEE Transactions on Biomedical Engineering 64 (15) (2005).
- [8] Y. Derlin, Y HenHu, Power Line Interference Detection and Suppression in ECG Signal Processing, IEEE transactions on Biomedical Engineering, 65 (Jan) 354-357.
- [9] N. V. Thakor, Y. S. Zhu, Applications of Adaptive Filtering to ECG Analysis: Noise Cancellation and Detection, IEEE Transactions on Biomedical Engineering, 39(9) (1991).
- [10] J. A. Vanalste, T. S. Schilder, Removal of Baseline Wander and Power Line Interface From the ECG by An Efficient FIR Filter With A Reduced Number of Taps, IEEE Transactions on Biomedical Engineering, 34(18) 1985.