



International Journal of Control Theory and Applications

ISSN : 0974-5572

© International Science Press

Volume 9 • Number 43 • 2016

Simulation and Analysis of Stator Resistance Variation Compensation Technique for Direct Torque Controlled Induction Motor Drive

Vishal. M. Gauswami^a, Tejas H. Panchal^b, Amit N. Patel^c and Vinod Patel^d

^{a-c}Department of Electrical Engineering, Institute of Technology, Nirma University, Ahmedabad-India. Email: ^a14meep11@nirmauni.ac.in; ^btejas.panchal@nirmauni.ac.in; ^camit.patel@nirmauni.ac.in

^dAGM, R&D Department, Amtech Electronics (I) Ltd. Gandhinagar, India 382028. Email: vinodp@amtechelectronics.com

Abstract: Direct Torque Control (DTC) has drawn attention of the induction motor drive designers because of its simplicity and fast dynamic response. Only stationary side transformation of voltages and currents are required to estimate flux and torque. The estimation of torque and flux is dependent of stator resistance. Resistance is always proportional to the temperature. Stator resistance varies according to variation in the temperature. Analysis of the effects of stator resistance variation with temperature on the performance of the DTC induction motor drives has been described. It is necessary to estimate precise value of the stator resistance online. This paper presents the stator resistance variation compensation technique using the stator current phasor error. Estimation of stator resistance is shown in real time simulation results.

Keywords: Direct Torque Control (DTC), Stator resistance, Stator reference phasor current vector, Temperature, Simulation.

1. INTRODUCTION

In all vector control methods of induction motor drives, Direct Torque Control method gains more importance because only one parameter, stator resistance is required. Direct Torque Controlled induction motor drive without mechanical sensor is hopeful in high performance industrial application. In this DTC scheme only stator side transformation is required. No use of modular block and current PI tuning drive becomes very simpler. Flux and torque are estimated through sensed stator current and stator voltage signals. Stator resistance is required to estimate the flux and torque. Classical DTC drive is first introduced by Takahashi which mainly depends on the switching table [1]. Stator voltages are reconstructed through the inverter dc link voltages and gate signals [2]. Flux error and torque error are restricted between the flux and torque hysteresis comparator bands. Flux hysteresis comparator has two levels Torque hysteresis comparator has three levels.

Stator flux angle is required in order to determine position of stator flux vector. As per flux error, torque error and number of sector in which flux vector lies, appropriate inverter voltage vectors are selected to restrict

the flux and torque within prescribed boundary. In order to obtain fast dynamic response of the drive, feedback signal is updated at every 25 μ s.

The variation in the value of stator resistance affects the performance of DTC induction motor drives especially at low speed. Stator resistance varies according to variation in temperature of stator windings. Neglecting the small amount of skin effect and stray loss, stator resistance primarily varies with temperature by the following equation.

$$R_s = R_{25} + \alpha_c R_{25} (T_s - 25^\circ)$$

where, R_s is the stator resistance at $T^\circ\text{C}$, R_{25} is the nameplate resistance (at 25 $^\circ\text{C}$), T_s is the temperature of stator winding and α_c is the temperature coefficient of the resistance of copper ($4.27 \times 10^{-3} \Omega/\Omega/^\circ\text{C}$).

The variation in stator resistance of 0.75 to 1.7 times of its nominal value due to temperature variation deteriorates the performance of the drive. It introduces errors in the magnitude of estimated flux linkage and position. Due to this, an error is introduced in the electromagnetic torque estimation, particularly at low speeds. At lower speed, voltage drop due to stator resistance constitute significant proportion of the applied stator voltages.

Some of the stator resistance variation compensation methods are introduced which are mainly dependent on the artificial intelligence technique [3], [4], [5]. The use of stator current phasor error with PI and fuzzy estimators presents a good performance for tuning the stator resistance [6]. The fuzzy estimator seems to outperform the PI based estimator thereby necessitating the use of intelligent control techniques to synthesize the adaptation mechanism. There has been no mention of how the stator current phasor reference is obtained to realize this scheme. The stability of system is not mentioned in all the proposed schemes.

2. DIRECT TORQUE CONTROL SCHEME

The principle of DTC is based on simultaneously decoupling the flux and electromagnetic torque. A basic schematic of Direct Torque Control is shown in Figure 1.

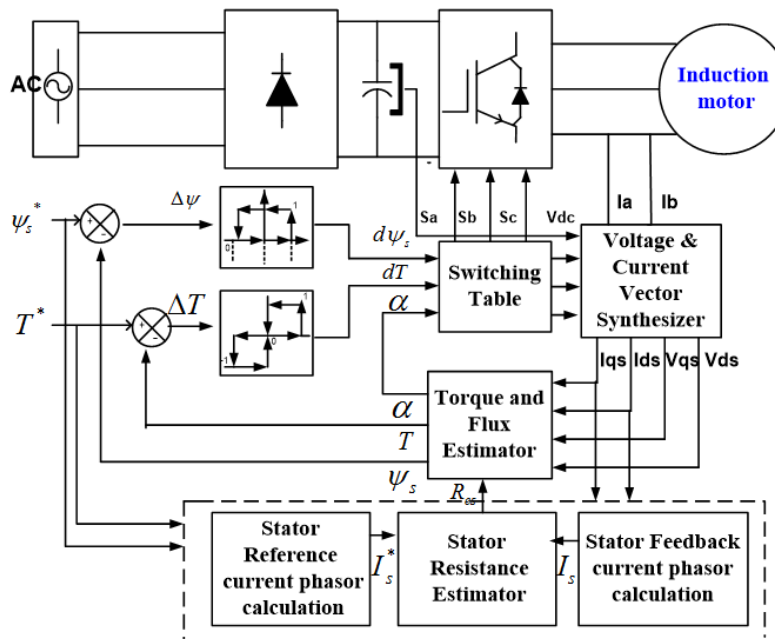

Figure 1: Block diagram of DTC scheme with stator resistance compensation method

Direct and quadrature axis components of currents are derived from the Clarke transformation,

$$i_{qs}^s = i_{as} \quad (1)$$

$$i_{ds}^s = \frac{\sqrt{3}}{2}(i_{cs} - i_{bs}) = -\frac{1}{\sqrt{3}}(i_{as} + 2i_{bs})$$

The stator d-axis and q-axis flux linkages components are evaluated from equations,

$$\Psi_{ds}^s = \int (v_{ds}^s - R_{es} i_{ds}^s) dt \quad (3)$$

$$\Psi_{qs}^s = \int (v_{qs}^s - R_{es} i_{qs}^s) dt \quad (4)$$

The magnitude of flux linkage and flux angle can be calculated as

$$\Psi_s = \sqrt{(\Psi_{ds}^s)^2 + (\Psi_{qs}^s)^2}$$

$$\alpha = \tan^{-1} \left(\frac{\Psi_{qs}^s}{\Psi_{ds}^s} \right) \quad (6)$$

Electromagnetic torque is given by,

$$T = \frac{3}{2} \frac{P}{2} (\Psi_{ds}^s i_{qs}^s - \Psi_{qs}^s i_{ds}^s) \quad (7)$$

where, R_{es} is the estimated stator resistance, I_{as} , I_{bs} and I_{cs} are stator phase currents, P is the number of poles. Stator resistance is the only parameter that affects all variables for feedback in the controller as seen from equations (1) to (7). The change in the value of stator resistance from 1 to 1.7 times its nominal value makes system unstable.

Variation in the value of stator resistance affects the performance of the DTC scheme. Drive system becomes unstable if there is a mismatch between the controller's estimated stator resistance and the actual machine resistance. In real time, as the temperature of the machine increases stator resistance also increases. If the value of stator resistance increases, then its stator current decreases which decreases the flux and electromagnetic torque. The controller reacts to this in opposite manner. The decreased currents, which are the inputs to the controller, cause decreased stator resistance voltage drops in calculation resulting in reduced flux linkages and electromagnetic torque estimation. They are compared with their reference values. A mismatch between actual torque, flux values and estimated torque, flux values by controller makes the system unstable.

The stator resistance compensation is essential to overcome instability of the drive. A stator resistance compensation scheme is presented in next section

3. STATOR RESISTANCE VARIATION COMPENSATION SCHEME

A flowchart of the applied stator resistance compensation scheme is shown in Figure 2 and its incorporation in the drive schematic is shown in Figure 1 in dotted lines. The error between the measured stator feedback current phasor magnitude i_s and its reference command current phasor i_s^* is proportional to the stator resistance variation which is caused by the motor temperature variation and to a smaller extent by the varying stator frequency.

The incremental value of stator resistance for compensation is obtained using PI controller and limiter. The current error goes through a low pass filter, which has very low cut off frequency in order to eliminate high

frequency components of the stator feedback current. This incremental stator resistance, ΔR_s , is continuously added to the previously estimated stator resistance, R_{s0} . The final estimated value, R_s , is obtained at the output of another low pass filter and limiter. This low pass filter is required for the smooth variation of the estimated stator resistance value. This final signal is the updated stator resistance and can be used in the controller. The above algorithm requires the stator current phasor command, which is not available directly in DTC drive system. The stator current phasor command is a function of the reference torque and reference stator flux linkages. The procedure to evaluate the stator current phasor command from the torque and stator flux linkages is described in the following section.

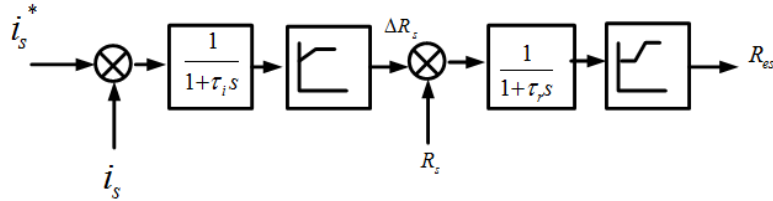

Figure 2: Flowchart of the adaptive stator resistance compensator

4. STATOR CURRENT REFERENCE PHASOR

The stator feedback current phasor magnitude i_s is obtained from the q -axis and d -axis measured current as,

$$i_s = \sqrt{(i_{qs}^2 + i_{ds}^2)} \quad (9)$$

The stator reference current phasor magnitude i_s^* is obtained from the dynamic equations of the induction motor in the synchronously rotating reference frame using the torque command T_e^* and stator flux linkage command ψ_s^* . The stator and rotor flux linkages in synchronously rotating frame are given by (10) to (13).

$$\Psi_{qs}^e = L_s i_{qs}^e + L_m i_{qr}^e \quad (10)$$

$$\Psi_{ds}^e = L_s i_{ds}^e + L_m i_{dr}^e \quad (11)$$

$$\Psi_{qr}^e = L_s i_{qr}^e + L_m i_{dr}^e \quad (12)$$

$$\Psi_{dr}^e = L_s i_{dr}^e + L_m i_{qs}^e \quad (13)$$

where, Ψ_{qs}^e, Ψ_{ds}^e are q-d axis stator flux linkages, Ψ_{qr}^e, Ψ_{dr}^e are q-d axis rotor flux linkages, i_{qr}^e, i_{dr}^e are q-d axis stator currents and i_{qs}^e, i_{ds}^e are q-d axis rotor currents in synchronously rotating reference frame. L_s and L_m are stator self-inductance and magnetizing inductance. The resultant stator flux linkage $\Psi_s =$ is assumed to be on direct axis.

In DTC scheme, stator flux phasor have only flux component. Hence aligning the d-axis with stator flux linkage phasor,

$$\Psi_{qs}^e = 0, p\Psi_{qs}^e = 0, \Psi_{ds}^e = \Psi_s^* \quad (14)$$

Substituting (14) in (10)

$$0 = L_s i_{qs}^e + L_m i_{qr}^e \quad (15)$$

$$i_{qr}^e = \frac{-L_s i_{qs}^e}{L_m} \quad (16)$$

By differentiating it,

$$\frac{di_{qr}^e}{dt} = \frac{-L_s}{L_m} \left(\frac{di_{qs}^e}{dt} \right) \quad (17)$$

and from substitute (14) in (11),

$$\psi_s^* = L_s i_{ds}^e + L_m i_{dr}^e \quad (18)$$

by differentiating it,

$$\frac{di_{dr}^e}{dt} = \frac{-L_s}{L_m} \left(\frac{di_{ds}^e}{dt} \right) \quad (19)$$

The electromagnetic torque in synchronously rotating reference frame is given by

$$T_e = \frac{3}{2} \frac{P}{2} (i_{qs}^e \psi_{ds}^e - i_{ds}^e \psi_{qs}^e) \quad (20)$$

Then the q-axis current command is directly obtained from (20) using the torque command T_e^* and stator flux linkage command ψ_s^* and inserting $\psi_{qs}^e = 0$ and $\psi_{ds}^e = \psi_s^*$

$$i_{qs}^{e*} = \frac{3}{2} \frac{P}{2} \frac{T_e^*}{\psi_s^*} \quad (21)$$

The rotor equations are given by

$$R_r i_{qr}^e + \omega_{sl} \psi_{dr}^e + \frac{d\psi_{qr}^e}{dt} = 0 \quad (22)$$

$$R_r i_{dr}^e + \omega_{sl} \psi_{qr}^e + \frac{d\psi_{dr}^e}{dt} = 0 \quad (23)$$

In steady state, $di_{qs}^e/dt = di_{ds}^e/dt = 0$. By using (15), (16) and (22), the resultant q-axis rotor equation that is a function of stator variable only is given

$$-\frac{R_r L_s}{L_m} i_{qs}^{e*} + \omega_{sl}^* L_m i_{ds}^{e*} \left(1 - \frac{L_s L_r}{L_m^2} \right) + \omega_{sl}^* \frac{L_r}{L_m} \psi_s^* = 0 \quad (24)$$

by Similarly, rotor d-axis equation can be derived in the steady state using (18), (23)

$$-\frac{R_r L_s}{L_m} i_{ds}^{e*} - \omega_{sl}^* L_m i_{qs}^{e*} \left(1 - \frac{L_s L_r}{L_m^2} \right) + \frac{R_r}{L_m} \psi_s^* = 0 \quad (25)$$

By solving (24) and (25),

$$L_s (i_{ds}^{e*})^2 - \psi_s^* \left(1 - \frac{L_s L_r}{L_m^2 - L_s L_r} \right) (i_{ds}^{e*}) + L_s (i_{qs}^{e*})^2 - \frac{L_r (\psi_s^*)^2}{L_m^2 - L_s L_r} = 0$$

Equation (26) gives two solutions for the i_{ds}^{e*} and the appropriate solution is the one which gives a smaller value. As i_{qs}^{e*} and i_{ds}^{e*} are now determined, the stator current phasor command magnitude is calculated as,

$$i_s^* = \sqrt{(i_{ds}^*)^2 + (i_{qs}^*)^2} \quad (27)$$

Note that dq axis stator current commands are independent from the stator and rotor resistances and so is the stator current phasor command. So, it is useful to find out stator current phasor error. Stator current feedback phasor and stator current reference phasor are calculated for the 10 hp induction motor at low frequency

The simulation is carried out for 10 hp, 415 V, 2-pole, 2930 rpm, 3- Φ induction motor to analyses effect of stator resistance variation on the performance of direct torque controlled drive system. It is presented in the next section.

5. SIMULATION AND RESULTS

Simulation results for DTC scheme and stator variation compensation scheme are carried out in PSIM Simulink. Parameters of the induction motor are described in appendix.

The stator phasor reference current derived from equation (27) is simulated in PSIM from the reference flux and reference torque. Stator reference current phasor vector is shown in Figure 3 when the induction motor is operated on no-load. As shown in Figure 3, actual stator current feedback phasor vector traces the derived reference current phasor vector.

A procedure for finding the stator current phasor command from the reference torque and stator flux linkage commands is derived to realize the adaptation scheme. Stator current phasor command derived from this procedure is independent of stator and rotor resistances of induction motor.

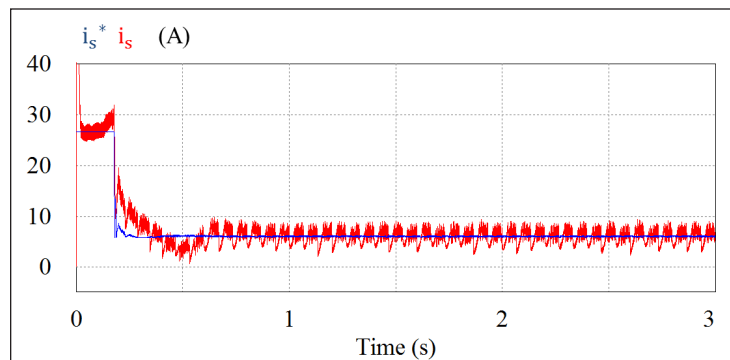
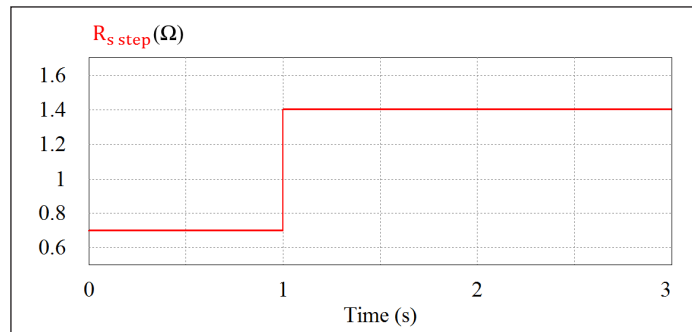

Figure 3: Estimated stator current reference phasor vector in no load condition.

The stator resistance voltage drop forms considerable proportion of applied voltage at low speed. Therefore, the performance of the system at a low speed due to variation in stator resistance deteriorates much more compared with that in the high speed range. Simulation is carried out at a low speed of about 10 % of the rated speed. Figure 4 shows the simulation results for a step change in the value of stator resistance for a parameter uncompensated drive system. The stator resistance of induction motor (10 hp, 415 V, 2930 rpm) is 0.702 Ω . As shown in Figure 4(a), the stator resistance is increased to twice of its nominal value after 1 s. As shown in Figure 4(b), the estimated stator current phasor reference does not follow the actual stator feedback current phasor. As shown in Figure 4(c), the motor is operated on no load upto 0.5 s. Rated torque command is applied at 0.5 s when the stator flux linkage has reached to its steady state value.

In the uncompensated system, right after the change of resistance, the generated electromagnetic torque decreases because motor voltage drop is higher than controller's estimated voltage drop. The stator flux linkages and stator current show similar worsening. Stator resistance voltage drop is higher in machine but estimated

stator resistance voltage drop is lower in the controller. This mismatch provides incorrect selection of voltage vector by controller leading to higher current flow into the machine terminal. Therefore, overall estimation of torque and flux is incorrect.



(a)

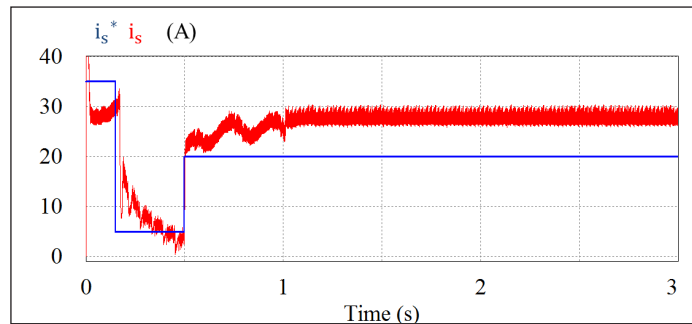

(b)

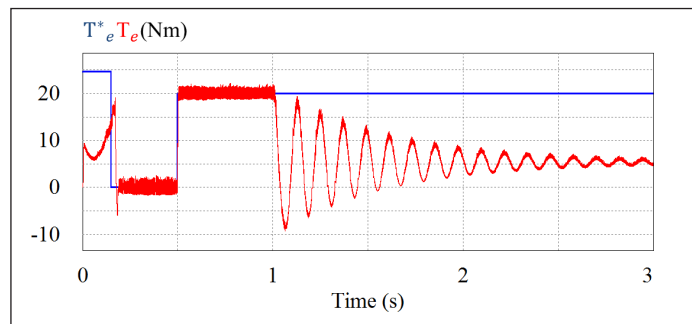

(c)

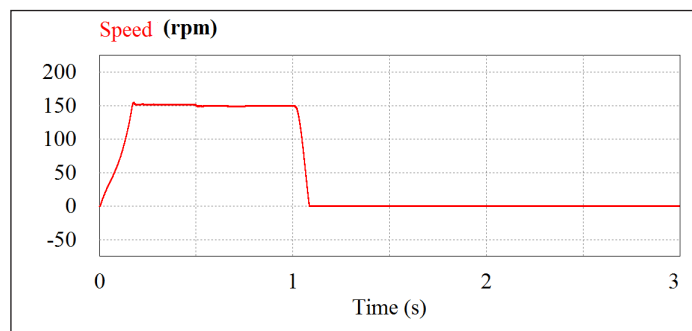

(d)

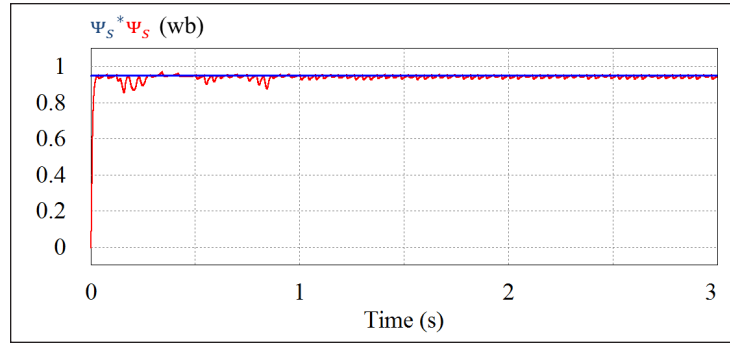

(e)

Figure 4. Parameter uncompensated DTC scheme (a) step change in stator resistance (b) measured stator feedback current phaser i_s and reference current phaser i_s^* (c) estimated and reference torques, T_e and T_e^* (d) Speed of IM (e) estimated and reference fluxes, Ψ_s and Ψ_s^*

Figure 5 shows the simulation results of a step change in stator resistance in parameter compensated scheme. As stator resistance varies in machine, current also changes in the machine. Error between stator reference current and feedback current should be compensated. The stator resistance is estimated from adaptive stator resistor compensator described in Section III.

As shown in Figure 5, in the compensated system, it is observed that stator resistance estimate suffers in the initial transient state and converges gradually to its final actual value in steady state. All the other variables also have initial transient state, but reach their final values in steady state. Motor torque deteriorates as step variation in stator resistance is applied and gradually reaches to its reference value. Flux linkages and motor speed have initial transient state, but reaches to their steady state values gradually.

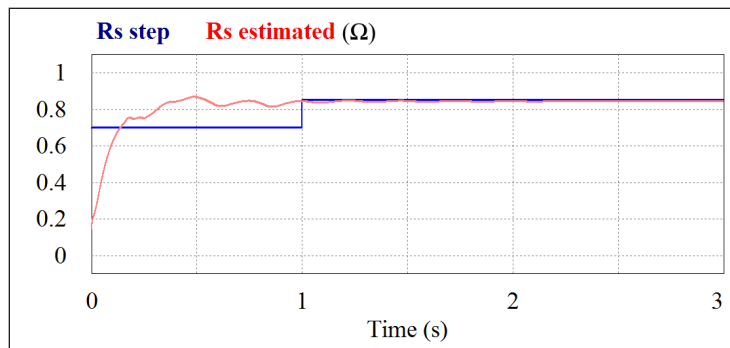

(a)

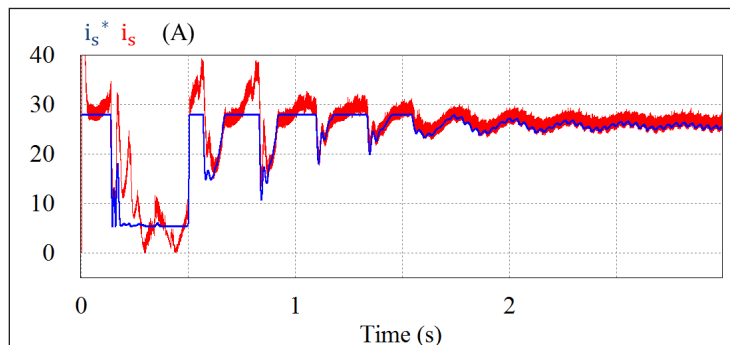

(b)

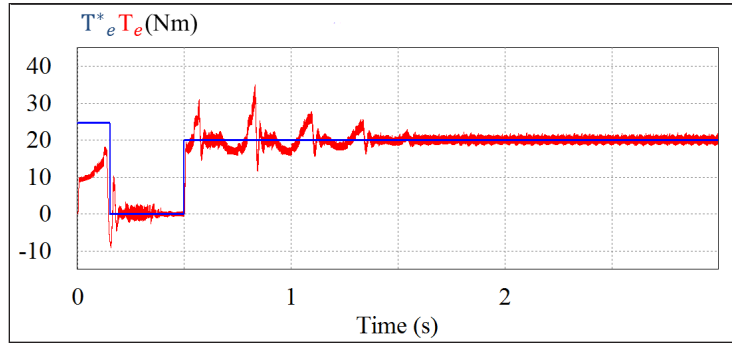

(c)

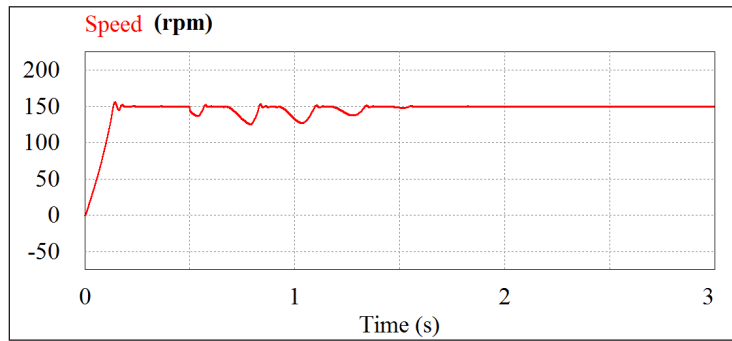

(d)

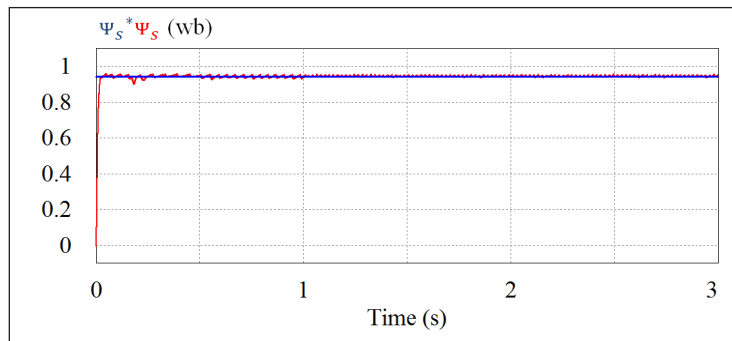

(e)

Figure 5. Parameter compensated DTC scheme (a) Step change in stator resistance (b) measured stator feedback current phaser i_s and reference current phaser i_s^* (c) estimated and reference torques, T_e and T_e^* (d) Speed of IM (e) estimated and reference fluxes, Ψ_s and Ψ_s^*

6. CONCLUSION

Dynamic simulations are presented to validate performance of the DTC induction motor drive with adaptive stator resistance variation compensation scheme. The stator reference current phaser i_s^* is derived from the reference flux and reference torque commands. The stator reference current phaser derived from this procedure is independent of stator and rotor resistances of induction motor. The variation in stator resistance is mainly caused by the motor temperature. A mismatch between the controller's set stator resistance and its actual value in the machine may deteriorate the performance of drive system and can create instability. The adaptive stator resistance compensator scheme presented in this paper estimates the variation in stator resistance accurately. The simulation results shows that performance of DTC induction motor drive is not deteriorated even step change in stator resistance is applied.

Appendix

Table 1
Induction motor parameters

Power (P_o)	10-hp(7.5 kW)
Line to Line Voltage (rms), supply frequency (f_o)	415 V, 50 Hz
Poles of machine (P)	2 poles
Stator resistance (R_s)	0.702 Ω
Stator leakage inductance (L_{ls})	0.0032805 mH
Rotor resistance (r'_r)	0.378 Ω
Rotor leakage inductance (l'_{lr})	0.0032805 mH
Mutual inductance (L_m)	1.171 mH
Rated speed (N)	2930 rpm

REFERENCES

- [1] Isao Takahashi and Toshihiko Noguchi, "A new quick-response and high efficiency control strategy of an induction motor", IEEE Transaction on Industrial Applications, Vol. 22, pp. 820-827, September - October, 1986.
- [2] Lee, Byeong-Seok, and R. Krishnan. "Adaptive stator resistance compensator for high performance direct torque controlled induction motor drives." Industry Applications Conference, 1998. Thirty-Third IAS Annual Meeting, Vol. 1. IEEE, 1998.
- [3] Bimal K. Bose, "Quasi-fuzzy estimation of stator resistance of induction motor", IEEE Transaction of Power Electronics, Vo. 13, Issue 3, pp. 401-409, 1998.
- [4] L. A. Cabera and M. E. Elbuluk, "Tuning the stator resistance of the induction motors using artificial neural network." Proc. of IEEE Power Electronics Specialists Conf. (PESC), Vol.1, pp. 421-427, 1995.
- [5] T. G. Habetler, F. Profumo, G. Griva, M. Pastorelli, and A. Bettini, "Stator resistance tuning in a stator flux field oriented drive using an instantaneous hybrid flux estimator," Conference proceedings, 5th European Conference on Power Electronics and Applications, Vol. 4, pp. 292-299, Brighton, UK, 1993.