



## International Journal of Control Theory and Applications

ISSN : 0974-5572

© International Science Press

Special Issue, 2016

### Voice Command Page Turning Robot for Physically Challenged People

<sup>1</sup>Durga K. Prasad Gudavalli, <sup>1</sup>Bh. Sudha Rani and <sup>1</sup>Sumanth Pemmada

<sup>1</sup> Asst. Professor, EEE Department, S. R. K. R. Engineering College, Bhimavaram, 534204, India

**Abstract:** According to the census of India 2011, over 26.8 million people in India are suffering from one or the other kind of disability, this is equivalent to 2.21% of total population of India. The disability cannot be destroyed, but we can reduce the problem of disabled persons with the help of growing technology. Disability in movement is one kind of disability where the person lost his/her both hands cannot be able to move to turn the pages while they want to read. To turn pages, they need to take help from others, so to avoid such problem this paper proposes an approach called Voice Command Page Turning Robot for physically challenged people. It is operated by using voice command as input to turn the required page either leftward or rightward. Here in this paper VR3 Voice Recognition Module is used, as it is like a brain in humans. It takes the user voice command as input and it sends information to the Micro Controller Unit to operate the motors in required manner for turning the page. This model gives self-confidence to the physically challenged persons and it is efficient method.

**Keywords:** Disabled persons; Micro Controller Unit; Voice Recognition Module; Voice Command Page Turning Robot; Right Command; Left Command; Vertical Motor; Horizontal Motor.

#### 1. INTRODUCTION

The percentage of disable population in India by type of disability in movement is 20.3%. Which is highest compared to remaining disabilities in India according to 2011 census (Source: C-Series, Table C-20, Census of India 2011). Persons having loss of hands (amputee) are feeling uncomfortable to read the books when it is needed to turn the pages, for every time they need to take help from others to turn the required pages. To avoid that problem, we have developed a model which can able to turn the required page by using a voice command in required manner. This model can also helpful for the paralyzed people, like those who do not able to move their hands and who wish to read books without depending on others. The proposed system gives the self confidence to fulfill their basic needs of user without depending on others help as well as it build up the self satisfaction by doing their work themselves only. To develop this model we have observed many page turners in Google and YouTube sources and in different research papers, those of some are discussed in the below section, but no project has perfectly turns the pages and no project has availability in cost. Therefore we initiated with these problems we make a model for the page turner for helping the physically challenged people.

An automated wheel chair for patient assistance has developed by J.Kathirvelan, R.Anilkumar, Zachariah C Alex and A.Fazul in 2012 [1].The developed wheel chair can be worked on the voice commands as its input

through a micro phone system and a voice recognition module [2]. When he/she uses a right command the chair moves to right and for left command it moves to left. This system gives us inspiration to develop voice command page turn model, from this system we have taken a voice command as input to the system so we have implemented it in our proposed methodology. An updated technology has developed for books scanning by replacing a human need in page flipping to scan the required page [3]. This technology is very fast in flipping the pages while the book is scanning; this source is applied in our system to turn the pages by automatically without taking human help.

In this paper Voice Recognition Module VR3 is used for recording and storing the voice commands to operate the Micro Controller Unit (MCU) according to the user requirement. To turn the page from Left Side to Right Side 'Right' Voice Command is recorded and to turn the page from Right to Left the 'Left' Voice Command is recorded

The rest of the paper is arranged as follows: Section 2 gives the overall view of proposed methodology, section 3 discusses the working, section 4 has results obtained and finally section 5 concludes the paper.

## 2. PROPOSED METHODOLOGY

The functional block diagram of proposed methodology is as shown in the Fig. 1. Here the user voice commands are given to the Voice Recognition Module as input signals to activate the voice recognition module and it send the input commanding signals to the Micro Controller Unit. Whether it is right or left command the micro controller unit operates the motors by L293D motor driver in such a manner to turn the required pages.

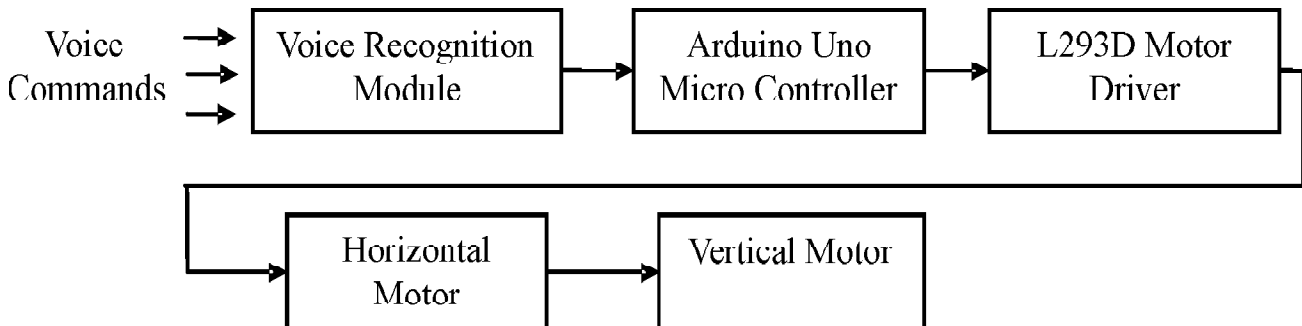

Figure 1: Functional Block Diagram of a Proposed Methodology

The subsystem components are explained briefly as follows.

### (A) Voice recognition module (VR3)

Elechouse Voice recognition VR3 module can record and stores up to 60 voice commands in a single module with different voice frequencies and from different persons. Hence we can provide specific work to each and individual voice frequencies and it can be able to matches its pre stored values when same voice given through the mice. Here in our solution we have recorded and stored two Voice Commands only: 'Right' for turning the Left Page to Right Side and 'Left' for turning the Right Page to Left Side. These two voice command will be fed to the MCU. VR3 operates on 4.5-5.5volts and rated current is less than 40mA. It has 3.5mm mono channel Micro Phone connector with Micro Phone Pin Analog Interface to receive the voice commands. The table 1 shows the serial communication between the voice recognition module and micro controller unit.

Table 1

Arduino	VR3 Module
5V	5V
2	TX
3	RX
GND	GND

The serial communication with the Micro Controller Unit is shown as in the table1.

### (B) Micro Controller Unit

The Arduino Uno is a micro controller unit, it is having 14 digital input/output pins out of which 6 pins are used for PWM controlling and it is operated at 5volts dc supply. It has great key features than other Micro Controller Units; with this MCU we can modify the program (code) along with the hardware connections. According voice commands feeding by voice recognition module, the Arduino micro controller sends the information to the motor drivers, to drive the vertical and horizontal motors as per designed in such a manner. Therefore, how the voice commands are recorded and stored in the voice recognition module is clearly shown in the Arduino serial monitor that is given in the results section below.

### (C) L293D Motor Driver

The L293D Motor Driver receives the Micro Controller Unit command signal to operate the Horizontal and Vertical Motor in a proper manner, it has a dual H-bridge driver Integrated Circuit (IC) used as a current amplifier. It takes 9 volts DC supply externally and it sufficiently runs two 5 volts dc geared motors at a time, when there is low currents occurred in the circuit, the driver module enhances its current to drive the motor with sufficient current mode and if high currents occurred, it limits the current to protect the motor. The L293D contains two inbuilt H-bridge driver circuits in its common mode of operation, so two DC motors can be driven simultaneously, both in forward and reverse direction at a time.

### (D) DC Geared Motor

12V, 60 rpm DC geared motors are used for Lifting and Turning the page. The two dc geared motors are connected in a capital English alphabet T, which are called a horizontal motor and vertical motors, on the top part of letter T shape is called horizontal motor and it contains a handle on its rotor. At the lower part of English letter T shape connection the motor is called vertical motor it holds the horizontal motor on its rotor. Through the motor driver power supply the Horizontal Motor lifts and holds the page with the help of double sided gum tape and the Vertical Motor make the page to leave in opposite side. The speed of the motor is controlled by Arduino PWM technique to stay the page in a required position.

## 3. WORKING

Fig. 2 shows the working model of proposed system, Voice Command Page Turning Robot for Physically Challenged People. Which is a voice based operating device to turn the required pages when user want to read the book without taking others help.

The Voice Recognition Module receives the voice commands as input and according to that input voice commands by the user it sends the information signals to the Micro Controller Unit then the motors are operated in such a manner to turn the pages. The system contains two Motors fitted on the board with a T- shape connection: A Horizontal Motor having a handle with double sided gum tape to hold the page, this motor lifts the page from

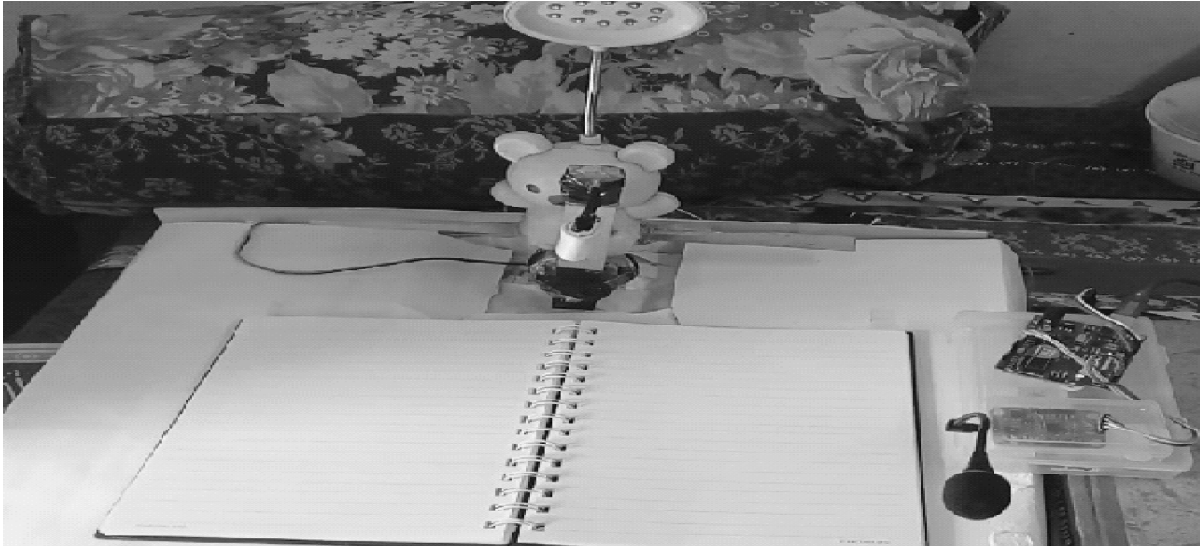

Figure 2: Proto Type of Voice Command Page Turner

bottom to up either from left bottom to up or right bottom to up based on the input command and a Vertical Motor, turns the Horizontal Motor in 180 degrees clock wise or anti clock wise. The input commands and step by step working of the system is shown in the table.2.

Table 2

Voice Command	Horizontal Motor Directions			Vertical Motor Directions with Horizontal Motor		
	Step1	Step2	Step3	Step4	Step5	Step 6
Right	↑	←	↑	↻	↻	↑
Left	↑	→	↑	↻	↻	↑

The step by step procedure for working of the system is explained as follows:

Table 2 shows Horizontal Motor handle with double gum tap and vertical motor directions in various positions for the respective voice commands such as Right and Left. For any of the two commands the process takes 6 steps to turn the page in required direction. These steps are briefly explained below.

**Right command:** When Right voice command is matched with the pre stored (Threshold) voice commands the Left Page is turned towards right side. To get this output the system takes 6 steps, that are explained individually each and every one as follows below.

**Step1:** The Page Turner Handle of Horizontal Motor is in its initial state, when right command is applied to the system, it ready to shift its position to step2 by 90° angle. In a 12 hours wall clock now its position is at 12 o clock position.

**Step2:** In this step the page turner handle is in 9 o clock position, now it touches the page and it hold the page by the double gum tap to lift page from bottom to up position (9 o clock to 12 o clock).

**Step 3:** The left side page is lifted by handle and now it's in a 12 o'clock position, to leaving the page in other side, the horizontal motor should be shifted to step 4.

**Step 4:** In this step the Vertical Motor rotates the Horizontal Motor in anticlockwise direction by  $180^\circ$ . Now the page which is holding on the handle is pulled out from gum tap and the horizontal motor is in exact back side to the 12 o'clock position.

**Step 5:** after some delay the horizontal motor gets back by vertical motor to its original position by exact  $180^\circ$ .

**Step 6:** This is the last step for page turner; now the turner position is same as like a step 1 which means it is in 12 o'clock positions to receive the user command again if it needed.

**Left command:** Left Voice Command is used for moving the Right Page towards Left side. Left Voice Command is also same as the Right voice Command but do the same actions by both horizontal and vertical motors in reverse manner. Left Command lifts Right Page and turned towards left side and the Vertical Motor turns the handle connected on horizontal motor in clockwise direction by  $180^\circ$  to pullout the page from double sided gum Tape, then again it comes to its initial position by turning  $180^\circ$  in anticlockwise direction. To get this output the system takes 6 steps, that are explained individually each and every one as follows below.

**Step 1:** The Page Turner Handle connected on Horizontal Motor is in its initial state, when left command is received by the user to the system, it ready to shifts its position to step2 by  $90^\circ$  angle direction. In a 12 hours wall clock now its position is at 12 o'clock position.

**Step 2:** In this step the page turner handle shifts to 3 o'clock positions, now the handle touches the page and it holds the page with double gum tap attached on the handle to lift the page from bottom to up position (3 o'clock positions to 12 o'clock positions).

**Step 3:** now the right side page is lifted by handle and now it's settled in a 12 o'clock position, to leaving the page in other side, the handle connected on the horizontal motor should be shifted to step 4.

**Step 4:** In this step the Vertical Motor turns the Horizontal Motor in clockwise direction by  $180^\circ$ . Angle, Now the page which is holded by the handle is pulled out from gum tap and the horizontal motor is in exact back side to the 12 o'clock position by  $180^\circ$  angle.

**Step 5:** after maintaining some delay the handle attached on the horizontal motor gets back by vertical motor to its original position by exact  $180^\circ$ , which means it is ready to settle in its original state.

**Step 6:** This is the last step for page turner; now the turner position is same as like a step 1 which means it is in 12 o'clock positions to receive the user voice command again to turn the required page as if it needed by user.

## 4. RESULTS

The experimental results for right page turn is as shown in the below figures and same procedure is followed to left page turn but the manner of page turning procedure will be quite reverse and along with experimental result obtained we have shown the voice recognition module results that are presented in Arduino serial monitor screen.

Here VR3 Voice Recognition Module is used, it has good compatibility with Arduino Micro Controller Uno and we have recorded and stored only two Voice Commands of same person as per our required Right and Left commands. The following will be explained how the voices were recorded and stored, we can clearly observe in the serial monitor of Arduino micro controller. From the below Fig.3 & 4. The serial monitor results shows us a 'Right' & Left voice commands are recorded and it is loaded into the voice recognition module. This voice commands is now used as Right & Left Voice Command input signals to the Arduino micro controller unit.

The right voice command is stored in Elechouse Voice Recognition V3 Module as shown in the figure above. As in the serial monitor result produced by Arduino micro controller the VR module takes right command as zero (0) value for the signature of right, now we have used this value as threshold value in our coding part. When the VR module gives this zero value as input command for the Arduino uno micro controller unit, it operates the motors as per their connection manner. Hence the page will be turned towards left side.

Same as like right command, the left voice command is stored in Elechouse Voice Recognition V3 Module as shown in the figure above. As in the serial monitor result produced by Arduino micro controller the VR module takes left command as one (1) value for the signature of left, now we have used this value as threshold value in our coding part. When the VR module gives this zero value as input command for the Arduino uno micro controller unit, it operates the motors as per their connection manner. Hence the page will be turned towards right side.

The Fig.5 shows the both Left and Right voice commands are recorded and loaded into the Voice Recognition Module to turn Left and Right pages by proper Voice Commands given by the user and the experimental results are shown in the below figure.

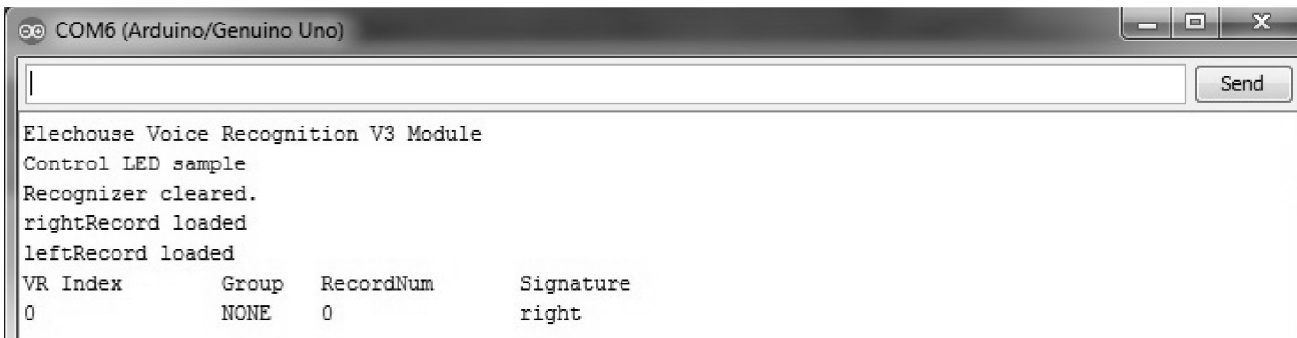

```
COM6 (Arduino/Genuino Uno)
Elechouse Voice Recognition V3 Module
Control LED sample
Recognizer cleared.
rightRecord loaded
leftRecord loaded
VR Index      Group   RecordNum   Signature
0             NONE    0           right
```

Figure 3: Right Command recorded

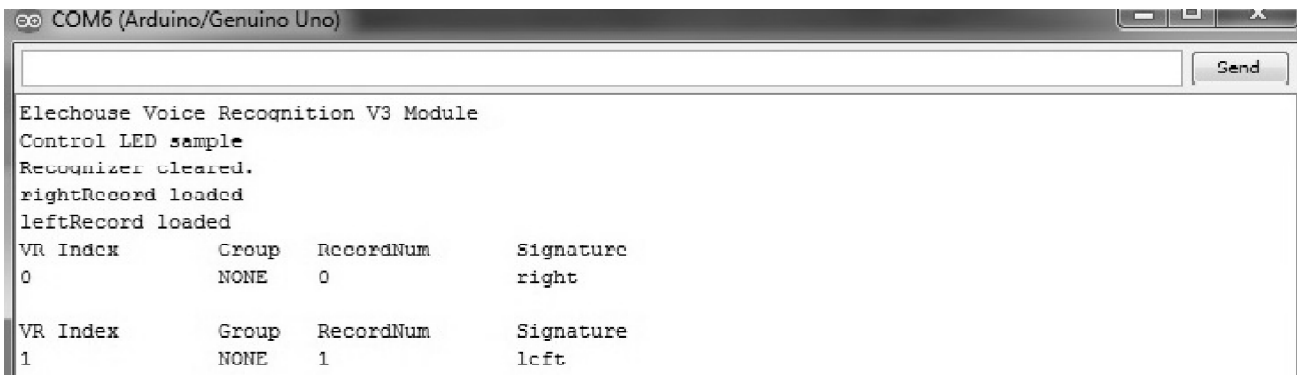

```
COM6 (Arduino/Genuino Uno)
Elechouse Voice Recognition V3 Module
Control LED sample
Recognizer cleared.
rightRecord loaded
leftRecord loaded
VR Index      Group   RecordNum   Signature
0             NONE    0           right
VR Index      Group   RecordNum   Signature
1             NONE    1           left
```

Figure 4: Left Command Recorded



```
COM6 (Arduino/Genuino Uno)
Elechouse Voice Recognition V3 Module
Control LED sample
Recognizer cleared.
rightRecord loaded
leftRecord loaded
```

Figure 5: Right & Left Records Loaded Into Voice Recognition Module

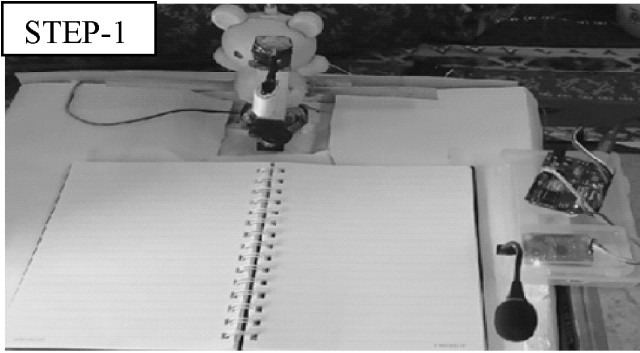

**Figure 6: The Page Turner Handle in Its Initial**

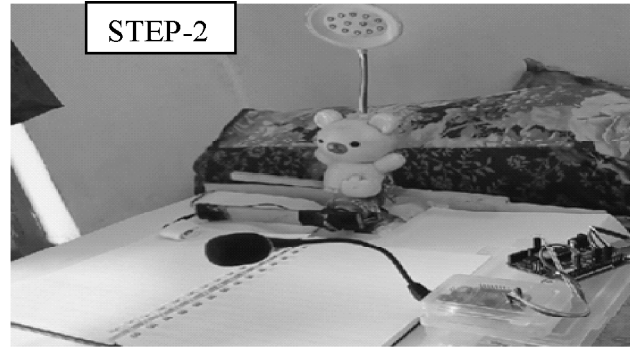

**Figure 7: The Page Turner Handle Moved To Left**

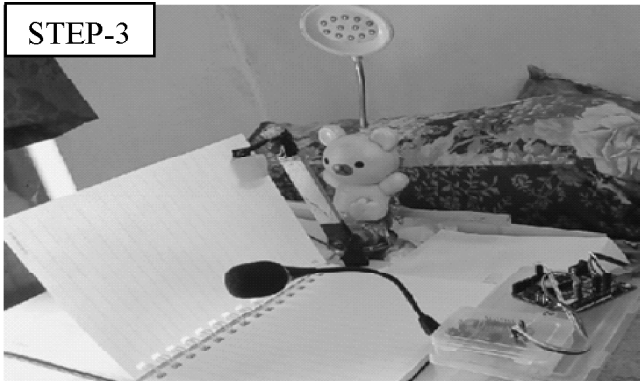

**Figure 8: Page Turner Handle Lifted & Hold the Page**

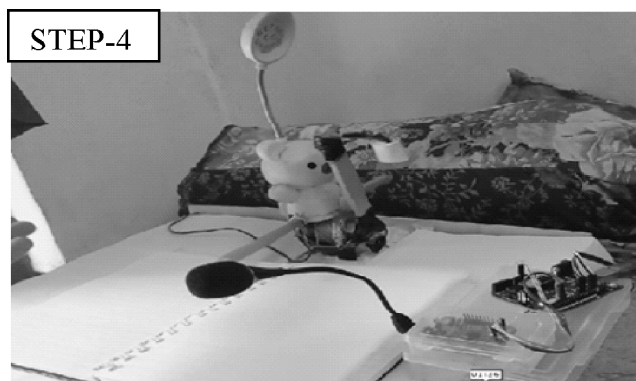

**Figure 9: The Page Turner Handle rotates anti clockwise direction by 180°**

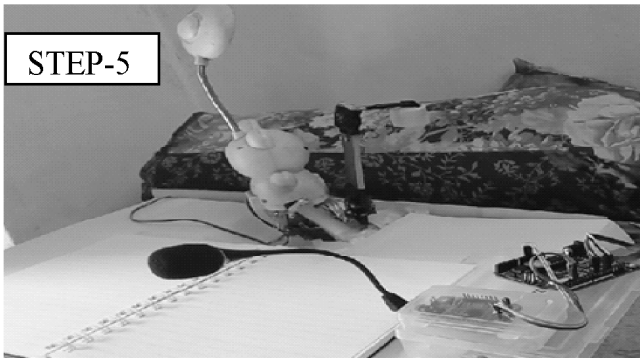

**Figure 10: Page Turner Handle returns to its original state by exact 180°**

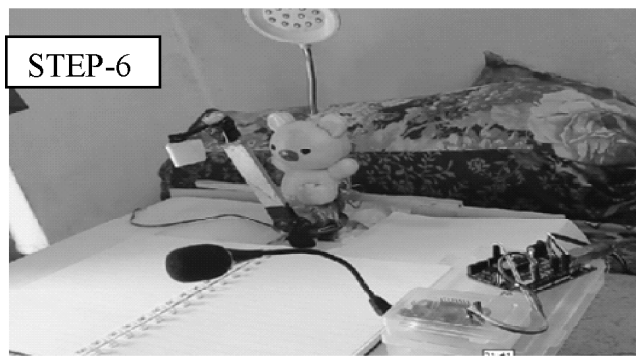

**Figure 11: The Page Turner at its original state**

## **5. CONCLUSION**

The Voice Command Page Turning Robot for Physically Challenged People is developed and tested. Normal page turner uses two switches for turning the required pages but in our proposed system the user voice command is enough to turn the required page. Here the Voice Recognition Module received the user voice commands as an input to the system and it send the information to the Arduino uno Micro Controller unit. Hence the Micro Controller Unit operated and controlled two dc geared motors in such a manner, whether it may be right page turn or left page turn. This system completely eliminates the use of switches for turning the pages and also

eliminates the problem of lifting group of pages, because it turns only one page at a time by sticking to the Double sided gum Tape attached on the Page Turner Handle. Therefore this model is very helpful to the physically disabled People as they can do the things on their own.

## **REFERENCES**

- [1] J. Kathirvelan, R. Anilkumar, Zachariah C Alex and A. Fazul, "Development of Low Cost Automatic Wheel Chair Controlled by Oral Commands Using Standalone Control System", 978-1-4673-1344-5/12/\$31.00@2012 IEEE.
- [2] Jose Stephen. AnjaliBhadran V.K, "Voice Enabled Multilingual Newspaper Reading System", 978-1-4799-1095-3/13/\$31.00@2013IEEE.
- [3] Yoshihiro Watanbe, Miho Tamei, Masahiro Yamada and Masatoshi Ishikawa, "Automatic Page Turner Machine for High Speed Book Digitization", 2013 IEEE/RSJ International Conference On Intelligent Robots And Systems(IROS) Nov 3-7, 2013, Tokoy, Japan.
- [4] Arduino software: <https://www.arduino.cc/>
- [5] VR3 Voice Recognition Module: [http://cxem.net/house/files/1-412\\_FZ0475.pdf](http://cxem.net/house/files/1-412_FZ0475.pdf)
- [6] L293D Motor Driver: <http://www.instructables.com/id/How-to-use-the-L293D-Motor-Driver-Arduino-Tutorial/>
- [7] 12v, 60rpm DC geared motor: <http://www.robotshop.com/>