

Optimal Control with State Observer of Ship Electric Propulsion System Using Double Star Synchronous Machine

Habib Dallagi*, Salmen Jaouidi* and Samir Nejim*

ABSTRACT

In this paper we are interested on themodelling, optimal control and numerical simulation of the ship electric propulsion system provided by a double star synchronous machine. The in-depth analysis of the operation of the propulsion system of the vessel allowed us to model elements of the propulsion system. Thus, a non-linear global model was obtained describing the operation of the entire propulsion system. The global model of the electric propulsion system of describing the dynamic behavior of the ship is nonlinear, multivariable and strongly coupled, which makes its control difficult. The nonlinear model is linearized about the nominal operating point on which an optimal control using a ship speed state observer is applied. The performances and the effectiveness of the studied approach applied to a ship electric propulsion is highlighted through numerical simulation, using Matlab/Simulink, to ensure perfect tracking of ship speed.

Keywords: Optimal control, Sate observer, Double star Synchronous motor, Ship electrical propulsion system.

1. INTRODUCTION

Today one notes a tendency toward the use of electrical power for ship propulsion which is made possible thanks to the improvement of the power electronics components. The advantage of the electric propulsion ship is to globalize all needs in energy, and with the same generators, to provide the necessary electrical power to the propulsion and to the local electric network [4], [10]. Some recent control methods are discussed in [15-20].

The major decision criteria for the adoption of electric propulsion vary from one ship type to another, acoustic discretion for submarines, research vessels and military ship, low noise and vibration for the ship cruise, perfect torque control at all speeds for an icebreaker, precision and flexibility for maneuverfor dynamic positioning ships, ferries or fishing vessels, space saving on tankers, to increase cargo or decrease the length of the vessels. To these criteria are added the advantages common to all types of ship, such as: reduced maintenance, increased operational safety, reduced pollution.

The multiphase machines are the subject of growing interest, especially the double synchronous motor star 'DSMS' for different reason, such as:

- As the multiphase machine contains several phases, this for a given power, the electric currents are reduced by phase and that power is distributed over the number of phases.
- Improved reliability by providing the ability to function properly degraded systems.

Generally the electrical equipment comprises two sets: Power & Propulsion:

- The power plant comprises generators driven by diesel engines. It supplies energy for all the distributors on the ship and in particular for propulsion equipment.

* U.R Automation & Robotics Marine (ARM), Naval Academy, *Emails: habib.dallagi@ept.rnu.tn, salmen.jaouadi@yahoo.fr, nejim.samir@planet.tn*

- The propulsion equipment comprises electric motors, controlled continuously by frequency converters for varying the speed of the propellers from 0 to 100% in both directions of rotation. Unlike diesel engines, the electric motors powered by the frequency converters are able to provide maximum torque at all times, even at very low speeds and in both directions of rotation. They therefore used the propeller with fixed blades whose braking ability of the ship is excellent when the rate is controlled by an electric motor. The torque provided by the electric motor is used to drive the propeller back whatever the speed of the ship. This paper deals mainly electric propulsion of a vessel equipped with a double Star synchronous motor. Modeling techniques for vessels electrically driven such that the electric drive motor, the propeller and movement of the ship, having a non-linear behaviour, have been developed. A simulation of the electric propulsion system of a vessel with control loop has been performed using the Matlab/Simulink software.

The first section is consecrated to the ship electric propulsion. The second section is devoted to the modeling of ship electric propulsion system. The resulting nonlinear model is linearized around nominal operating point is treated to third section. The fourth section focuses to techniques of optimal control and its main criteria. The observer construction is studied in the fifth section and in the last section numerical simulations using the Matlab/Simulink software are reported to highlight the efficiency of the proposed control scheme.

2. SHIP ELECTRIC PROPULSION SYSTEM MODEL

2.1. Description of ship propulsion system

The electric motor of propulsion is entirely integrated in a directional nacelle fixed under the hull outside the ship Fig.1. The motor is coupled mechanically with a fixed blade propeller shaft. The electric machine, which equips the ships, must be [4]:

- Compact, light and reliable.
- Robust to the marine environment (vibration, moisture, saline environment, temperature variation).
- Discrete with low noises and vibrations. In addition the forces applied to the ship are:

T: thrust developed by propeller,

R: the hull resistance applied by the sea opposing the ship movement

T_{ext} : applied strength by the outside environment on the ship, induced by the wind and the waves

Fig.1.

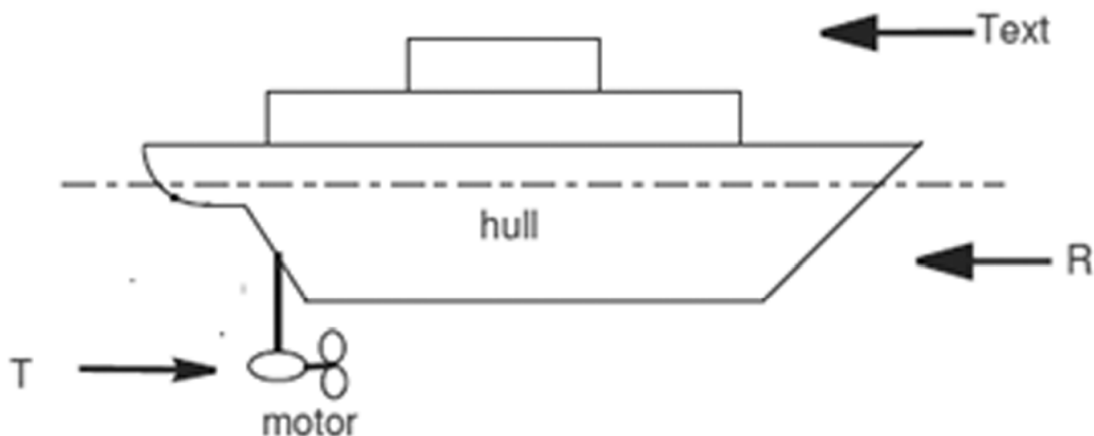

Figure 1: The force representation applied to a ship

2.2. Double star synchronous motor model

The propulsion of the ship is provided by a motor MSDE. The model of the machine in the natural base is significantly complicated because of the dependence of the inductance to the rotor position Fig. 1. To overcome to this complexity, that the Park transformation consists in converting the model of the machine in three-phase stator winding ($a_1, b_1, c_1, a_2, b_2, c_2$) of a two-phase model axis (d, q is used) [1, 2, 10]. This transformation is represented by the Fig. 2. The double star synchronous motor built with two symmetrical tree phase armature winding systems, electrically shifted by 30° and its rotor is excited by current source.

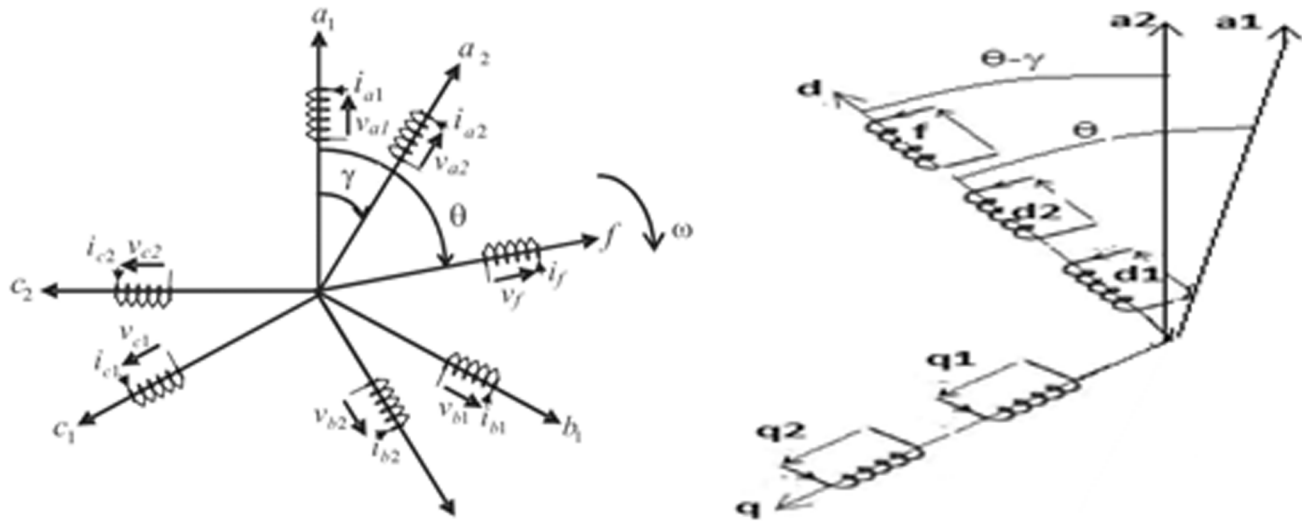

Figure 2: MSDE Machine and Park MSDE representation, with $\gamma = 30^\circ$

The voltage equations of the double star synchronous motor are written as follows [2], [11], [12], [13].

$$\begin{cases} V_{d1} = R_S I_{d1} + \frac{d}{dt} \phi_{d1} - \omega_r \phi_{q1} \\ V_{d2} = R_S I_{d2} + \frac{d}{dt} \phi_{d2} - \omega_r \phi_{q2} \\ V_{q1} = R_S I_{q1} + \frac{d}{dt} \phi_{q1} + \omega_r \phi_{d1} \\ V_{q2} = R_S I_{q2} + \frac{d}{dt} \phi_{q2} + \omega_r \phi_{d2} \\ V_f = R_f I_f + \frac{d\phi_f}{dt} \end{cases} \quad (1)$$

2.2.1. Magnetic Equations

$$\begin{cases} \phi_{d1} = L_d I_{d1} + M_d I_{d2} + M_{fd} I_f \\ \phi_{d2} = L_d I_{d2} + M_d I_{d1} + M_{fd} I_f \\ \phi_{q1} = L_q I_{q1} + M_q I_{q2} \\ \phi_{q2} = L_q I_{q2} + M_q I_{q1} \\ \phi_f = L_f I_f + M_{fd} (I_{d1} + I_{d2}) \end{cases} \quad (2)$$

The different currents $I_{d1}, I_{d2}, I_{q1}, I_{q2}, I_f$ are calculated based on flux $\phi_{d1}, \phi_{d2}, \phi_{q1}, \phi_{q2}, \phi_f$

From the eq. (2) of flux we obtain the following expressions:

$$\begin{cases} I_{d1} = \frac{L_d \phi_{d1} - M_d \phi_{d2}}{L_d^2 - M_d^2} - \frac{M_{fd}}{L_d + M_d} I_f \\ I_{d2} = \frac{M_d \phi_{d1} - L_d \phi_{d2}}{M_d^2 - L_d^2} - \frac{M_{fd}}{L_d + M_d} I_f \\ I_{q1} = \frac{L_q \phi_{q1} - M_q \phi_{q2}}{L_q^2 - M_q^2} \\ I_{q2} = \frac{M_q \phi_{q1} - L_q \phi_{q2}}{M_q^2 - L_q^2} \end{cases} \quad (3)$$

2.2.2. Electromagnetic torque

The electromagnetic torque is produced by the interaction between the poles formed by magnets to the rotor and the poles caused by magneto-motive F.M.M force in the gap generated by the stator currents. It is expressed by: $C_{em} = C_{em1} + C_{em2}$

$$\text{With:} \quad C_{em1} = p(\phi_{d1} I_{q1} - \phi_{q1} I_{d1}) \text{ and } C_{em2} = p(\phi_{d2} I_{q2} - \phi_{q2} I_{d2})$$

Where the Electromagnetic torque:

$$C_{em} = p(\phi_{d1} I_{q1} + \phi_{d2} I_{q2} - \phi_{q1} I_{d1} - \phi_{q2} I_{d2}) \quad (4)$$

2.2.3. Mechanical equation

$$I_m \frac{d}{dt} \Omega = C_{em} - Q - Q_f \quad (5)$$

The mechanical equation of the shaft is:

$$I_m \dot{\Omega} = p(\phi_{d1} I_{q1} + \phi_{d2} I_{q2} - \phi_{q1} I_{d1} - \phi_{q2} I_{d2}) - Q - Q_f \quad (6)$$

2.2.4. Modelling of the hull resistance

The total resistance is given in Newton and it is estimated by the expression [11], [12]:

$$R_T = [R_F(1 + K_1) + R_W + R_{APP} + R_B + R_{TR} + R_A + R_{AIR}](1.0 + DMRA/100) \quad (7)$$

Where:

- R_f : friction resistance,
- $1 + K_1$ = coefficient depending on the shape of the hull,
- R_{APP} : appendages resistance (rudder, ailerons stabilizers ..)
- R_W : wave resistance,

- R_B : resistance due to the presence of a bulbous bow near the water surface,
- R_A : resistance due to the roughness of the hull and air resistance,
- R_{TR} : Whirlpool resistance can be neglected because the hull's shape,
- R_{air} : aerodynamic drag,
- DMAR: design margin on the strength in percent. The total resistance is increased by the term (+1.0 DMAR/100)

This resistor can be modeled by a simple model which consists in approximating the total resistance by the square of the ship speed, given by [5], [7]:

$$R = a V^2 \quad (8)$$

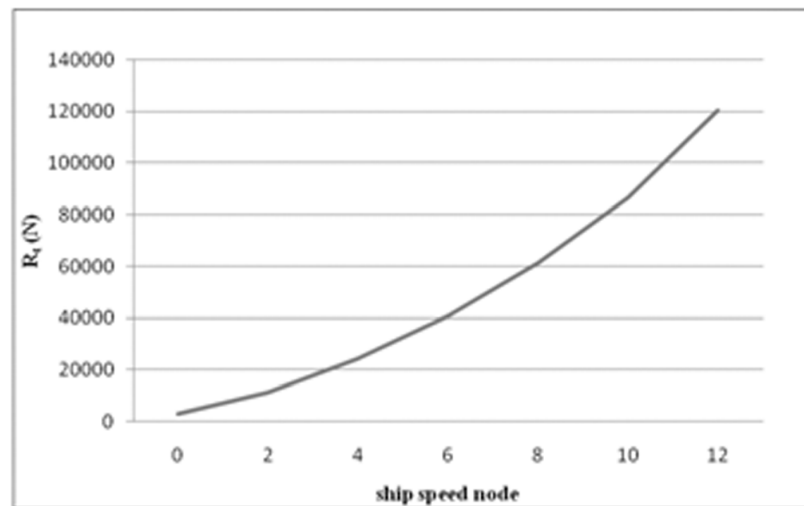

Figure 3: Hull resistance

The value of “a” is calculated from the curve of Fig. 3 and its numerical value is:

$$a = 606.53 \text{ N / noeud}$$

2.2.5. Propeller Equation

When the propeller rotates in the sea, it develops torque and propelling force to move the ship. Experience shows that the thrust T and the torque Q depends on the following parameters:

- ρ : Water density.
- D : Propeller diameter
- n : Propeller speed.
- V_a : propeller advanced speed

The model of the propelling force T (thrust) and the torque of the propeller Q can be written respectively [5], [7], [10]:

$$T = \rho K_T D^4 n^2 \text{ and } Q = \rho K_Q D^5 n^2 \quad (9)$$

The coefficients K_T and K_Q depends on the propeller's advanced speed, the propeller pitch, the ship's speed, the advance coefficient, wake coefficient and the propeller speed. The equations characterizing J and V_a are given by:

$$J = \frac{V_a}{nD} \quad \text{and} \quad V_a = (1-\omega)V \quad (10)$$

To plot the characteristic curves of the propeller, we used a Propeller Optimization Program (POP) developed by the University of Michigan department of naval architecture. This program allows the tracing of curves $K_T = f(J)$, $K_Q = f(J)$ and $\text{Eta} 0 = (J)$ Fig.4. The diagrams and coefficients are determined from field trials on the ship studied [5], [7]. These diagrams are shown in the following figure representing the evolution of K_T and K_Q according to J , with $n = \Omega / 2\Pi$.

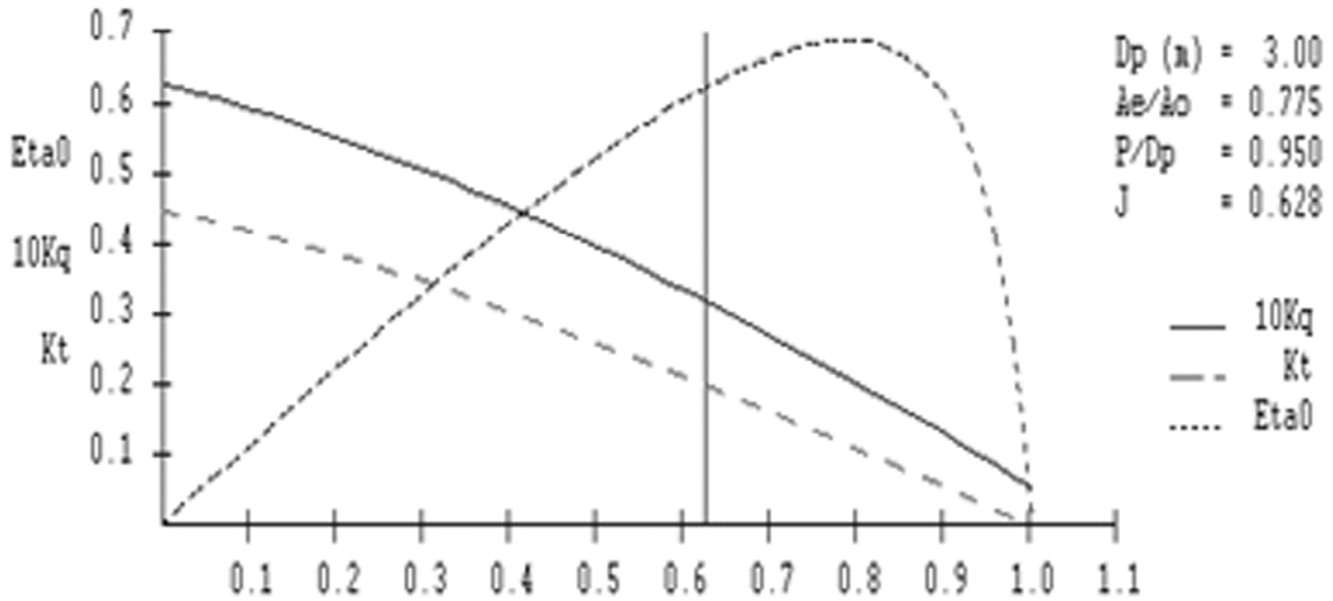

Figure 4: Curve K_T and K_Q according to J

The Curves $K_T = f(J)$ and $K_Q = f(J)$ can be approximated by straight lines given by the following expressions:

$$K_T = r_1 + r_2 J \quad \text{and} \quad K_Q = s_1 + s_2 J \quad (11)$$

The parameters r_1 , r_2 , s_1 and s_2 are constants that vary from one ship to another.

The thrust T and the torque Q are functions of n and V_a for different values of pitch propeller. Typical curves of thrust and torque coefficients of the propeller are given by the previous figures, where K_T and K_Q are based on J .

$$T = \rho D^4 (r_1 + r_2 J) n^2 \quad \text{and} \quad Q = \rho D^5 (s_1 + s_2 J) n^2 \quad (12)$$

After substituting the expressions n and V_a the expression of K_T becomes:

$$K_T = r_1 + \frac{r_2}{nD} (1-\omega)V \quad (13)$$

Similarly and after substituting the expressions of J and V_a the expression K_Q becomes:

$$K_Q = s_1 + \frac{s_2}{nD} (1-\omega)V \quad (14)$$

By replacing the coefficients K_T in the expression T of the propeller thrust T , the new expression of T is:

$$T = r_1 \rho n^2 D^4 + r_2 \rho n^2 D^3 (1 - \omega) V \quad (15)$$

By replacing the coefficients K_Q in the expression Q of the propulsion torque Q becomes, the new expression of Q is:

$$Q = s_1 \rho n^2 D^5 + s_2 \rho n^2 D^4 (1 - \omega) V \quad (16)$$

2.2.6. Ship motion equation

The ship floating on the sea surface is subjected to external and hydrodynamic forces. The propulsion system comprises a motor coupled to a propeller shaft and a propeller with fixed blades. The equation of vessel motion is given by the following relationship [10]:

$$m\dot{V} = -R + (1-t)T - T_{ext} \quad (17)$$

The equation of the shaft mechanical of the double star synchronous motor is:

$$I_m \dot{\Omega} = C_{em} - Q - Q_f \quad (18)$$

2.3. The block ship movement

The system being studied is a vessel propelled by a double star synchronous motor coupled to a propeller with fixed blades whose main components are decomposed into beings subsystem. Fig. 5 provides an overview on the structure of the system and the inputs and outputs of different subsystems.

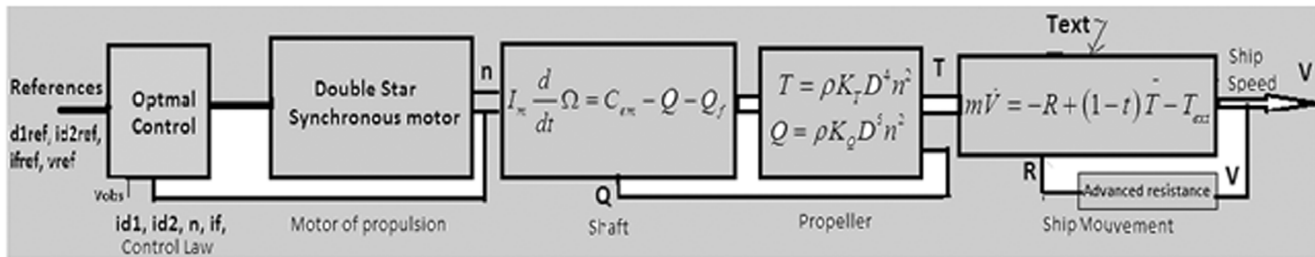

Figure 5: Observed state feedback optimal control

2.4. Setting as state of the overall system

By replacing the electromagnetic torque C_{em} and propulsion torque Q by their respectively expressions (4) and (16) in the equation of the shaft line movement (18), we get the following equation:

$$I_m \dot{\Omega} = p(\phi_{d1} I_{q1} + \phi_{d2} I_{q2} - \phi_{q1} I_{d1} - \phi_{q2} I_{d2}) - s_1 \rho \frac{1}{4\pi^2} \Omega^2 D^5 - \frac{1}{4\pi^2} s_2 \rho \Omega^2 D^4 (1 - \omega) V - Q_f \quad (19)$$

Similarly by replacing the hull resistance R as well as the propeller thrust T by their respective expression (8) and (15), the vessel's motion eq. (17) becomes:

$$m\dot{V} = -aV^2 + \frac{1}{4\pi^2} (1-t) r_1 \rho D^4 \Omega^2 + \frac{1}{2\pi} (1-t) (1-\omega) r_2 \rho D^3 \Omega V - T_{ext} \quad (20)$$

2.5. Global Model of the Ship Electric Propulsion System

The global model of the ship electric propulsion using double star synchronous motor is represented by the following system.

$$\left\{ \begin{aligned}
\frac{d}{dt} id_1 &= \frac{L_d \frac{d}{dt} \phi_{d1} - M_d \frac{d}{dt} \phi_{d2}}{L_d^2 - M_d^2} - \frac{M_{fd}}{L_d + M_d} \frac{dif}{dt} \\
\frac{d}{dt} iq_1 &= \frac{L_q \frac{d}{dt} \phi_{q1} - M_q \frac{d}{dt} \phi_{q2}}{L_q^2 - M_q^2} \\
\frac{d}{dt} id_2 &= \frac{M_d \frac{d}{dt} \phi_{d1} - L_d \frac{d}{dt} \phi_{d2}}{M_d^2 - L_d^2} - \frac{M_{fd}}{L_d + M_d} \frac{dif}{dt} \\
\frac{d}{dt} iq_2 &= \frac{M_q \frac{d}{dt} \phi_{q1} - L_q \frac{d}{dt} \phi_{q2}}{M_q^2 - L_q^2} \\
\frac{d}{dt} if &= \frac{\frac{d}{dt} \phi_f - M_{fd} \left(\frac{d}{dt} i_{d1} + \frac{d}{dt} i_{d2} \right)}{L_f} \\
\frac{d\Omega}{dt} &= \frac{1}{I_m} \left[p \left(\phi_{d1} I_{q1} + \phi_{d2} I_{q2} - \phi_{q1} I_{d1} - \phi_{q2} I_{d2} \right) - s_1 \rho \frac{1}{4\pi^2} \Omega^2 D^5 - \frac{1}{4\pi^2} s_2 \rho \Omega^2 D^4 (1-\omega) V - Q_f \right] \\
\frac{dV}{dt} &= \frac{1}{m} \left[-aV^2 + \frac{1}{4\pi^2} (1-t) r_1 \rho D^4 \Omega^2 + \frac{1}{2\pi} (1-t)(1-\omega) r_2 \rho D^3 \Omega V - T_{ext} \right]
\end{aligned} \right. \quad (21)$$

By replacing the eq. (2) in eq. (21) it yields the system (22). Thus there was obtained a highly non-linear system of order seven. The parameters of the system are given the in appendix.

$$\left\{ \begin{aligned}
\frac{did_1}{dt} &= k_1 I_{d1} + k_2 \Omega I_{q1} + k_3 I_{d2} + k_4 \Omega I_{q2} + k_5 I_f + k_6 V_{d1} + k_7 V_{d2} + k_8 V_f \\
\frac{diq_1}{dt} &= l_1 \Omega I_{d1} + l_2 I_{q1} + l_3 \Omega I_{d2} + l_4 I_{q2} + l_5 \Omega I_f + l_6 V_{q1} + l_7 V_{q2} \\
\frac{did_2}{dt} &= m_1 I_{d1} + m_2 \Omega I_{q1} + m_3 I_{d2} + m_4 \Omega I_{q2} + m_5 I_f + m_6 V_{d1} + m_7 V_{d2} + m_8 V_f \\
\frac{diq_2}{dt} &= n_1 \Omega I_{d1} + n_2 I_{q1} + n_3 \Omega I_{d2} + n_4 I_{q2} + n_5 \Omega I_f + n_6 V_{q1} + n_7 V_{q2} \\
\frac{dif}{dt} &= p_1 I_{d1} + p_2 \Omega I_{q1} + p_3 I_{d2} + p_4 \Omega I_{q2} + p_5 I_f + p_6 V_{d1} + p_7 V_{d2} + p_8 V_f \\
\frac{d\Omega}{dt} &= q_1 I_{d1} I_{q1} + q_2 I_{d2} I_{q1} + q_3 I_f I_{q1} + q_4 I_f I_{q2} + q_5 I_{d2} I_{q2} + q_6 I_{d1} I_{q2} + q_7 \Omega^2 + q_8 \Omega^2 V + q_9 \\
\frac{dV}{dt} &= t_1 V^2 + t_2 \Omega^2 + t_3 \Omega V + t_4
\end{aligned} \right. \quad (22)$$

3. LINEARIZATION OF THE SHIP ELECTRIC PROPULSION SYSTEM

The global model of the ship electric propulsion using double star synchronous motor is represented by the following system.

$$\begin{cases} \dot{x} = f(x) + g(x)u \\ y = h(x) \end{cases} \quad (23)$$

An industrial system is often intended to operate in regulation mode, i.e. the system output has to track an imposed reference signal despite of the various disturbances. Under these conditions, the use of nonlinear state representation for the purpose of control is not necessary. A linear local state representation is sufficient [6], [14]. The linearization of (22), around an operating point characterized by (x_0, y_0, u_0) , is given by:

$$\begin{cases} \dot{x} = Ax + Bu \\ y = Cx \end{cases} \quad (24)$$

Where:

- $x = [id_1 \quad iq_1 \quad id_2 \quad iq_2 \quad if \quad \Omega \quad V]^T$ the state vector
- $u = [vd_1 \quad vq_1 \quad vd_2 \quad vq_2 \quad vf]^T$ the input vector
- A, B and C are the Jacobean matrices given by: $A = \frac{\partial f}{\partial x} /_{x=x_0}$; $B = \frac{\partial f}{\partial u} /_{u=u_0}$; $C = \frac{\partial h}{\partial x} /_{x=x_0}$;

$$A = \begin{pmatrix} -109.6780 & 4.0394 & 103.9583 & -26.9821 & -0.2466 & 84.0972 & 0 \\ -8.0633 & -123.0687 & -1.9583 & 111.9313 & -39.9284 & -939.4783 & 0 \\ 103.9583 & -1.0060 & -109.6780 & -4.0797 & -0.2466 & -84.0392 & 0 \\ -1.9583 & 111.9313 & -8.0633 & -123.0687 & -39.9284 & -1.4333e+003 & 0 \\ -0.0563 & 0.0280 & -0.0563 & 0.0280 & 0.0619 & 0.9342 & 0 \\ 524.0292 & 8.8059e+003 & 524.0208 & 8.8062e+003 & 9.3585e+003 & -8.6481e+005 & 7.3986e+005 \\ 0 & 0 & 0 & 0 & 0 & 0.2071 & -0.1739 \end{pmatrix}$$

$$B = \begin{pmatrix} 46.6715 & 0 & -44.2376 & 0 & 0.0239 \\ 0 & 52.3697 & 0 & -47.6303 & 0 \\ -44.2376 & 0 & 46.6715 & 0 & 0.0239 \\ 0 & -47.6303 & 0 & 52.3697 & 0 \\ 0.0239 & 0 & 0.0239 & 0 & -0.0060 \\ 0 & 0 & 0 & 0 & 0 \\ 0 & 0 & 0 & 0 & 0 \end{pmatrix} \quad C = \begin{pmatrix} 1 & 0 & 0 & 0 & 0 & 0 & 0 \\ 0 & 0 & 1 & 0 & 0 & 0 & 0 \\ 0 & 0 & 0 & 0 & 1 & 0 & 0 \\ 0 & 0 & 0 & 0 & 0 & 0 & 1 \end{pmatrix}$$

4. OPTIMAL CONTROL PRINCIPLE

To obtain an optimal control law for the ship electric propulsion system, we minimize the following criterion [3], [8], [9]:

$$J = \frac{1}{2} \int_0^{\infty} (u^T R u + \varepsilon^T Q \varepsilon) dt \quad (25)$$

With: R a symmetric positive definite matrix, Q a symmetric non-negative definite matrix. The control law is then given by:

$$u(t) = Fe(t) - Kx(t) \quad (26)$$

Where: $\varepsilon(t) = e(t) - y(t)$ is the difference between the reference and the output vector.

With $e(t) = [\text{id}_{1\text{ref}} \quad \text{id}_{2\text{ref}} \quad v_{\text{ref}} \quad i_{\text{fref}}]^T$ the reference vector

The gain F is given by:

$$F = R^{-1} B^T (A^T - P B R^{-1} B^T)^{-1} P C Q \quad (27)$$

The gain K is given by the equation:

$$K = R^{-1} B^T P \quad (28)$$

Where P is the solution of the Riccati equation:

$$\dot{P} + PA + A^T P - P B R^{-1} B^T P + Q = 0 \quad (29)$$

with $Q = C^T Q C$

5. SHIP SPEED STATE OBSERVER

To design the state feedback optimal control law, it is necessary to reconstruct the ship speed V in order to be controlled. For this purpose, we propose a linear state observer using the output vector

$y(t) = [\text{id}_1 \quad \text{id}_2 \quad \text{if} \quad n]^T$ and the input vector $u(t) = [u_{d1} \quad u_{d2} \quad u_{q1} \quad u_{q2} \quad u_f]^T$

The structure of a Luenberger observer is given by:

$$\begin{cases} \dot{\hat{x}} = A\hat{x} + Bu + L(y - \hat{y}) \\ \hat{y} = C\hat{x} \end{cases} \quad (30)$$

Where: \hat{y} is the output vector of the state observer. The matrix L is the observer gain. This structure can be written in this form:

$$\dot{\hat{x}} = \hat{A}\hat{x} + Bu + Ly \quad (31)$$

with $\hat{A} = A - LC$

To have an asymptotic convergence of the observed state towards the real state, it is necessary to choose the gain L such that the matrix $(A - LC)$ has negative real part eigen values. The control law using the state observer is presented as follows [8], [9]:

$$u(t) = Fe(t) - K\hat{x}(t) \quad (32)$$

6. NUMERICAL SIMULATION RESULTS

The Q and R matrices are chosen as follows:

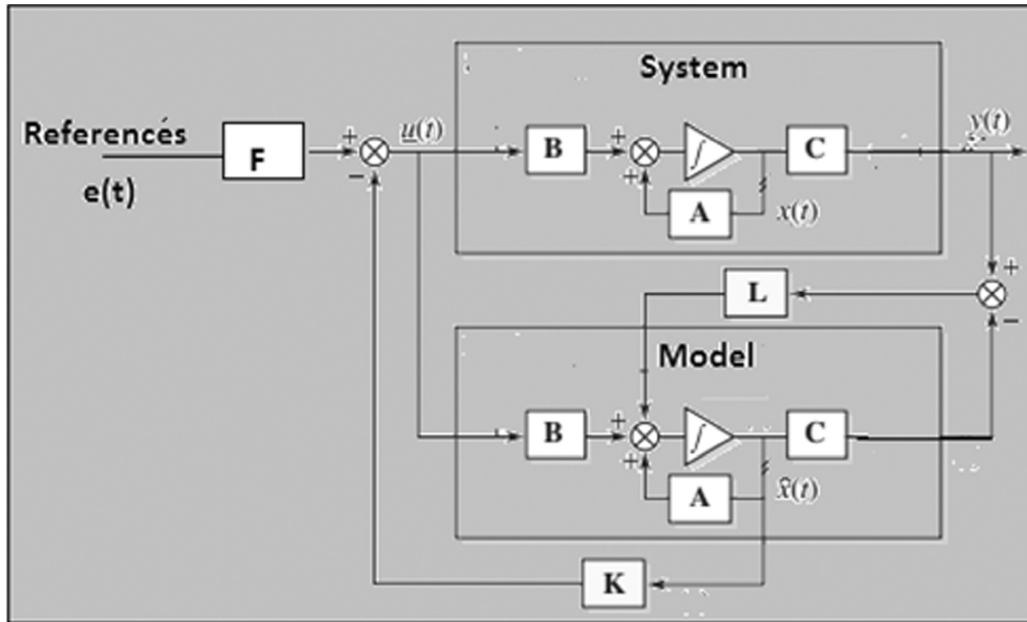

Figure 6: Observed state feedback optimal control

$$R = \begin{pmatrix} 1 & 0 & 0 & 0 & 0 \\ 0 & 1 & 0 & 0 & 0 \\ 0 & 0 & 1 & 0 & 0 \\ 0 & 0 & 0 & 1 & 0 \\ 0 & 0 & 0 & 0 & 1 \end{pmatrix} \quad Q = \begin{pmatrix} 1 & 0 & 0 & 0 \\ 0 & 1 & 0 & 0 \\ 0 & 0 & 1 & 0 \\ 0 & 0 & 0 & 1 \end{pmatrix}$$

The gain of the optimal control K_{opt} obtained is the following:

$$K_{opt} = \begin{pmatrix} 0.2156 & -0.0270 & 0.0123 & -0.0491 & 0.5529 & 0.0001 & 9.9110 \\ 0.2804 & -0.0689 & 0.2750 & -0.1089 & 0.1815 & 0.0003 & 12.6652 \\ 0.0297 & -0.0326 & 0.2339 & -0.0450 & 0.5552 & 0.0001 & 10.4330 \\ -0.4321 & 0.1126 & -0.4269 & 0.1746 & 0.0328 & -0.0004 & -12.5267 \\ 0.0024 & -0.0007 & 0.0024 & -0.0011 & -0.1366 & 0.0000 & -1.4717 \end{pmatrix}$$

The gain matrix of the observer obtained L is:

$$L = \begin{pmatrix} -33.1224 & -38.1385 & 3.7903 & 0 \\ -4.4125 & 2.0247e+003 & -77.9131 & 0 \\ 115.8725 & 32.9322 & -2.4066 & 0 \\ -60.0017 & 1.9653e+003 & -77.0144 & 0 \\ -0.1563 & -4.5709 & 0.1902 & 0 \\ 471.5962 & 611.1918 & 9.3571e+003 & 0 \\ -0.0077 & -6.7310 & -0.0170 & 0 \end{pmatrix}$$

The reference gain matrix F obtained by the resolution of the eq. (27):

$$F = \begin{pmatrix} -0.0128 & -0.0120 & -0.7868 & 24.2730 \\ -0.0225 & -0.0225 & 5.1470 & -64.2004 \\ -0.0130 & -0.0139 & -0.4640 & 22.0222 \\ 0.0165 & 0.0166 & -7.2765 & 22.0306 \\ 0.0016 & 0.0016 & 0.7343 & -9.7874 \end{pmatrix}$$

The transition matrix P determined from the Riccati equation is:

$$P = \begin{pmatrix} 0.0514 & -0.0124 & 0.0493 & -0.0196 & 0.0038 & 4.6558e-005 & 1.6386 \\ -0.0124 & 0.0037 & -0.0125 & 0.0055 & 0.0234 & -1.3096e-005 & 0.1406 \\ 0.0493 & -0.0125 & 0.0518 & -0.0195 & 0.0038 & 4.6117e-005 & 1.6444 \\ -0.0196 & 0.0055 & -0.0195 & 0.0083 & 0.0219 & -1.9839e-005 & -0.1113 \\ 0.0038 & 0.0234 & 0.0038 & 0.0219 & 22.7619 & 2.4780e-005 & 258.0307 \\ 4.6558e-005 & -1.3096e-005 & 4.6117e-005 & -1.9839e-005 & 2.4780e-005 & 4.7843e-008 & 0.0028 \\ 1.6386 & 0.1406 & 1.6444 & -0.1113 & 258.0307 & 0.0028 & 1.0270e+004 \end{pmatrix}$$

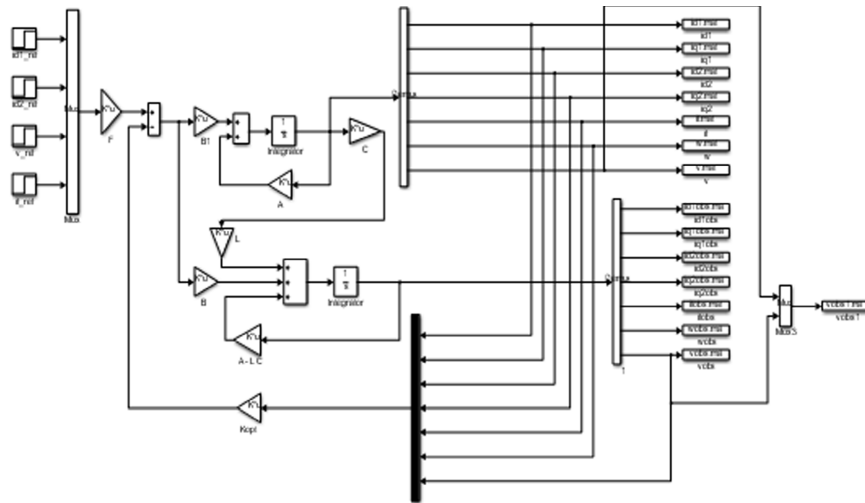

Figure 7: Block diagram of simulation

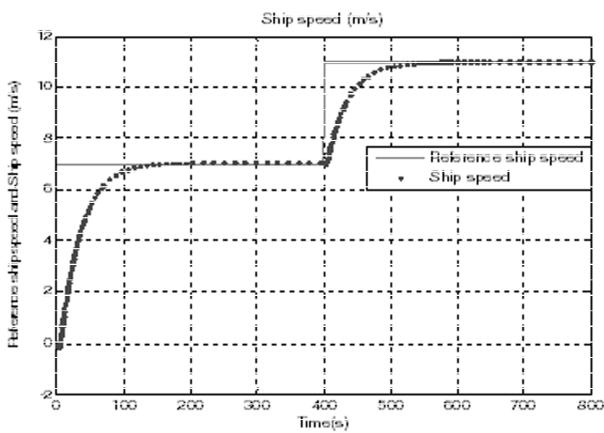

Figure 8: Reference ship speed and ship speed

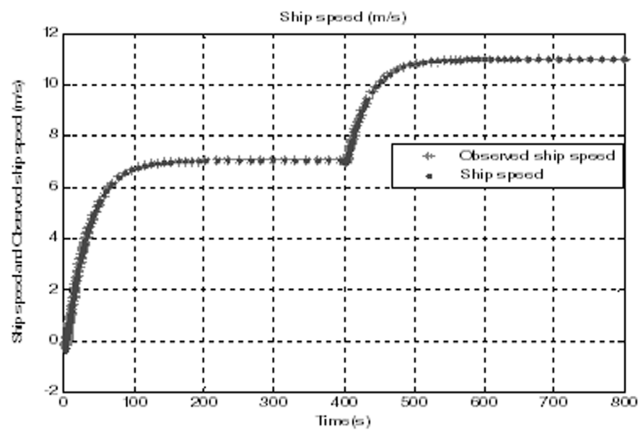

Figure 9: Observer ship speed and ship speed

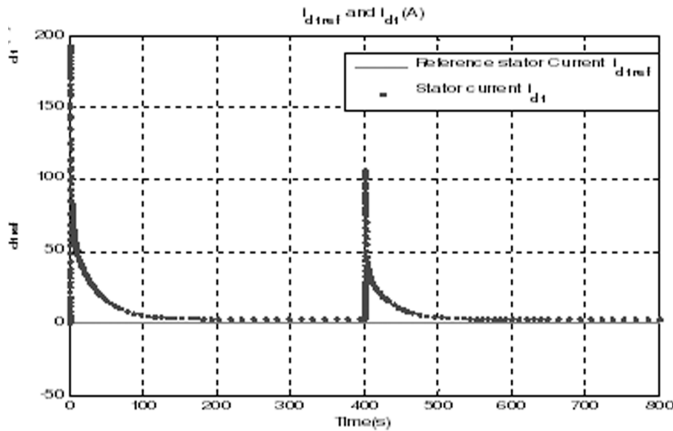

Figure 10: Reference stator current i_{d1ref} and stator current i_{d1}

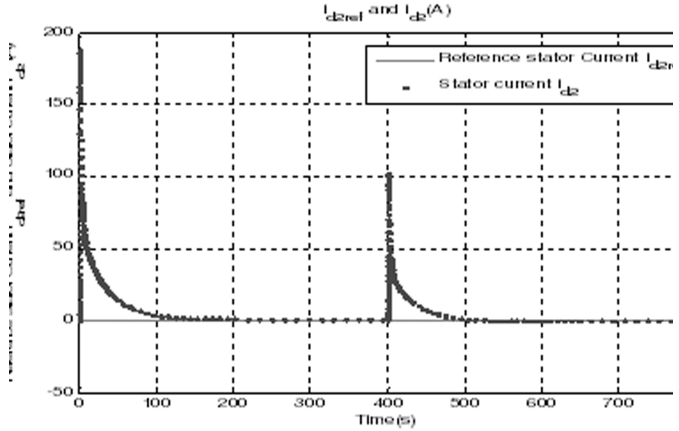

Figure 11: Reference stator current i_{d2ref} and stator current i_{d2}

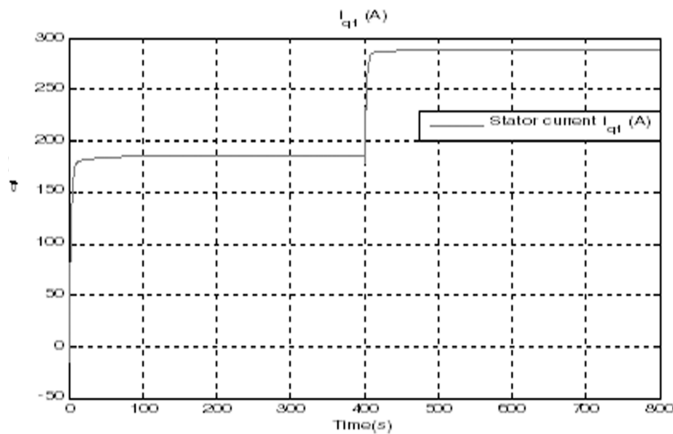

Figure 12: Stator current i_{q1}

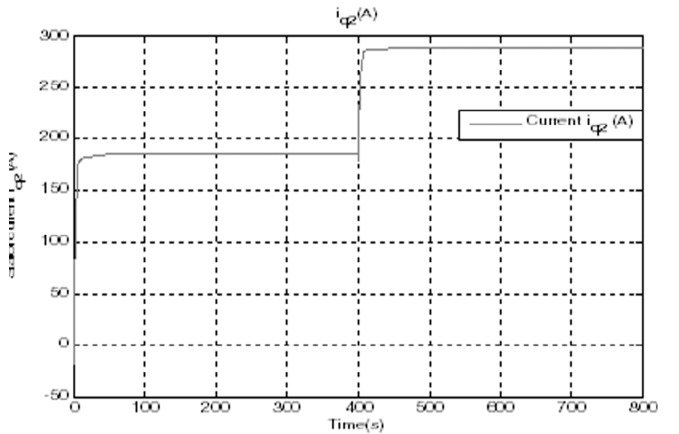

Figure 13: Stator current i_{q2}

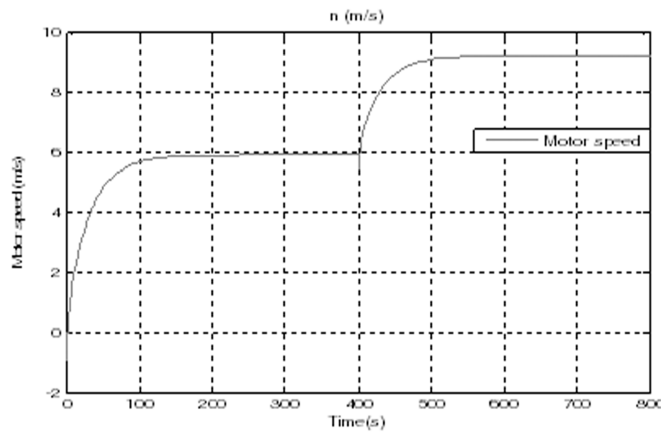

Figure 14: Motor speed

7. RESULTS INTERPRETATION

The performance of the proposed strategy of the control law is shown in the previous figures. The ship speed is necessary for the reference speed $v_{ref} = 7\text{m/s}$ in the range $[0, 400\text{s}]$ and $v_{ref} = 11\text{m/s}$ in the interval $[400, 800\text{s}]$. It is clear from Fig.8 that the proposed control law has enabled a convergence from the desired value of the ship speed. Fig. 14 shows the behaviour of the motor speed. It is clear that the ship speed change when the propeller speed changes. In addition, we impose $i_{d1ref} = 0$ and $i_{d2ref} = 0$ as shown in Fig. (10) and Fig. (11), so that the electromagnetic torque is proportional to currents i_{q1} and i_{q2} , the control the motor

speed by changing the electromagnetic torque C_{em} changing currents i_{q1} and i_{q2} as shown in Fig. (12) and Fig. (13), through regulating voltages V_{q1} and V_{q2} .

8. CONCLUSION

In this paper, we have proposed a model of the ship electric propulsion system using double star synchronous motors. The obtained global model is strongly nonlinear.

We have used an optimal control law with Luenberger observer to control the ship speed. The observer designed is used to reconstruct the ship's speed to complement the control strategy. It has been shown from the simulation results that the state feedback optimal control proposed allows the regulation of the ship speed converges exactly to the reference imposed. The digital validation was performed from a program written in Matlab/Simulink. The simulation results show the validity and the relevance of the proposed approaches.

In addition, simulations were carried out and the obtained results show the accuracy of the developed model and will enable us to contribute to the development of ship electric propulsion systems by proposing new strategies of control and of power management. Other operations of the system can be easily studied. The use of double star synchronous motor for the ship propulsion as well as their control, constitute the innovating aspects of this work.

ACKNOWLEDGMENT

This work was supported by the "Ministry of Higher Education and Scientific Research".

APPENDIX

The simulation results are obtained with the following parameters and values:

$$\begin{aligned}
 k_1 &= \frac{-L_d R_s}{L_d^2 - M_d^2} - \frac{M_{fd}^2 R_s}{(L_d + M_d)L_f((L_d + M_d) - 2M_{fd}^2)} & k_5 &= \frac{M_{fd} R_f}{L_f((L_d + M_d) - 2M_{fd}^2)} \\
 k_2 &= \frac{L_d L_q - M_d M_q}{L_d^2 - M_d^2} + \frac{M_{fd}^2(L_q + M_q)}{(L_d + M_d)L_f((L_d + M_d) - 2M_{fd}^2)} & k_8 &= \frac{-M_{fd}}{L_f((L_d + M_d) - 2M_{fd}^2)} \\
 k_3 &= \frac{M_d R_s}{L_d^2 - M_d^2} - \frac{M_{fd}^2 R_s}{(L_d + M_d)L_f((L_d + M_d) - 2M_{fd}^2)} \\
 k_4 &= \frac{L_d M_q - M_d L_q}{L_d^2 - M_d^2} + \frac{M_{fd}^2(L_q + M_q)}{(L_d + M_d)L_f((L_d + M_d) - 2M_{fd}^2)} \\
 k_6 &= \frac{L_d}{L_d^2 - M_d^2} + \frac{M_{fd}^2}{(L_d + M_d)L_f((L_d + M_d) - 2M_{fd}^2)} \\
 k_7 &= \frac{-M_d}{L_d^2 - M_d^2} + \frac{M_{fd}^2}{(L_d + M_d)L_f((L_d + M_d) - 2M_{fd}^2)} & m_8 &= \frac{-M_{fd}}{L_f((L_d + M_d) - 2M_{fd}^2)} \\
 m_1 &= \frac{-M_d R_s}{M_d^2 - L_d^2} - \frac{M_{fd}^2 R_s}{(L_d + M_d)L_f((L_d + M_d) - 2M_{fd}^2)} & m_5 &= \frac{M_{fd} R_f}{L_f((L_d + M_d) - 2M_{fd}^2)}
 \end{aligned}$$

$$\begin{aligned}
m_2 &= \frac{M_d L_q - L_d M_q}{M_d^2 - L_d^2} + \frac{M_{fd}^2 (L_q + M_q)}{(L_d + M_d) L_f ((L_d + M_d) - 2M_{fd}^2)} \quad p_1 = \frac{M_{fd} R_s}{L_f ((L_d + M_d) - 2M_{fd}^2)} \\
m_3 &= \frac{L_d R_s}{M_d^2 - L_d^2} - \frac{M_{fd}^2 R_s}{(L_d + M_d) L_f ((L_d + M_d) - 2M_{fd}^2)} \quad q_1 = \frac{p(L_d - L_q)}{I_m}; \quad q_2 = \frac{p(M_d - M_q)}{I_m}; \\
m_4 &= \frac{M_d M_q - L_d L_q}{M_d^2 - L_d^2} + \frac{M_{fd}^2 (L_q + M_q)}{(L_d + M_d) L_f ((L_d + M_d) - 2M_{fd}^2)} \quad q_3 = \frac{p M_{fd}}{I_m} \quad q_4 = \frac{p M_{fd}}{I_m}; \\
n_5 &= \frac{(L_q M_{fd} - M_q M_{fd})}{(M_q^2 - L_q^2)} \quad m_6 = \frac{M_d}{M_d^2 - L_d^2} + \frac{M_{fd}^2}{(L_d + M_d) L_f ((L_d + M_d) - 2M_{fd}^2)} \quad q_5 = \frac{p(L_d - L_q)}{I_m}; \\
q_6 &= \frac{p(M_d - M_q)}{I_m} \quad n_7 = \frac{-L_q}{(M_q^2 - L_q^2)} \quad t_2 = \frac{(1-t)r_1 \rho D^4}{4\pi^2 m} \quad t_3 = \frac{(1-t)(1-w)r_2 \rho D^3}{2\pi m} \quad q_7 = \frac{-s_1 \rho D^5}{4\pi^2 I_m}; \\
q_8 &= \frac{-s_2 \rho D^4 (1-w)}{4\pi^2 I_m} \quad q_9 = \frac{-Q_f}{I_m} \quad t_1 = \frac{-a}{m} \quad p_2 = \frac{-M_{fd} (L_q + M_q)}{L_f ((L_d + M_d) - 2M_{fd}^2)} \quad t_4 = \frac{-T_{ext}}{m} \\
p_3 &= \frac{M_{fd} R_s}{L_f ((L_d + M_d) - 2M_{fd}^2)} \quad p_4 = \frac{-M_{fd} (L_q + M_q)}{L_f ((L_d + M_d) - 2M_{fd}^2)} \quad p_5 = \frac{-(L_d + M_d) R_f}{L_f ((L_d + M_d) - 2M_{fd}^2)} \\
l_1 &= \frac{(M_q M_d - L_q L_d)}{(L_q^2 - M_q^2)} \quad l_2 = \frac{-L_q R_s}{(L_q^2 - M_q^2)} \quad l_3 = \frac{(M_q L_d - M_d L_q)}{(L_q^2 - M_q^2)} \quad l_4 = \frac{M_q R_s}{(L_q^2 - M_q^2)} \quad n_2 = \frac{-M_q R_s}{(M_q^2 - L_q^2)} \\
l_5 &= \frac{(M_q M_{fd} - L_q M_{fd})}{(L_q^2 - M_q^2)} \quad l_6 = \frac{L_q}{(L_q^2 - M_q^2)} \quad l_7 = \frac{-M_q}{(L_q^2 - M_q^2)} \quad n_1 = \frac{(L_q M_d - M_q L_d)}{(M_q^2 - L_q^2)} \quad n_6 = \frac{M_q}{(M_q^2 - L_q^2)} \\
n_3 &= \frac{(L_q L_d - M_d M_q)}{(M_q^2 - L_q^2)} \quad n_4 = \frac{L_q R_s}{(M_q^2 - L_q^2)}
\end{aligned}$$

$L_d=0.196$ H, $R_f = 10.3\Omega$, $L_q=0.1105$ H, $M_d=0.185$ H, $R_s=2.35\Omega$, $M_q=0.1005$ H, $p=2$, $L_f=15$ H, $w=0.2304$,
 $t=0.178$, $a=606.53$, $M_{fd}=1.518$ H, $S_1=0.063$, $J=3\text{Kg}\cdot\text{m}^2$, $S_2=-0.0577$, $\rho=1025$ Kg/m³, $m=905000$ Kg,
 $r_1=0.44$, $D=3$ m, $r_2=-0.4489$;

REFERENCES

- [1] A. J. Sørensen, "Marine Cybernetics: Modelling and Control, Department of Marine Technology Norwegian," University of Science and Technology Report UK-05-76 Copyright 2005 Department of Marine Technology, NTNU.
- [2] L. Parsa and H. A. Toliyat, "Five-Phase Permanent Magnet Motor Drives for Ship Propulsion Applications," IEEE Electric Ship Technologies Symposium, 2005, pp. 371-378,
- [3] S. S. Rao, John Wiley, "Engineering Optimization: Theory and practice," 1996, New York,
- [4] H. Dallagi and S. Nejim, "Modelisation and Simulation of an Electric Drive for a Two Propeller Ship," 17ème Congrès Mondial IMACS, Calcul Scientifique, Mathématiques Appliquées et Simulation, Paris, France, 11 - 15 Juillet 2005,
- [5] H. Dallagi and S. Nejim, "Optimization of an Integrated Power System of an Electric Ship," International Conference on ship propulsion and railway traction systems, Bologna-Italy, 2006, 4, 5, 6 Octobre,
- [6] H. DALLAGI and A. S. TLILI and S. NEJIM, "A Feedback Linearization Control of Ship Electric propulsion," SSD'07, 2005, Hammamet - Tunisia, March 19-22,

- [7] H. Dallagi , C. Mechmeche and S. Nejim, “The Modeling of Ship electric propulsion system for faults detection and Isolation,” Fourth International Multi-Conference on Systems, Signals and Devices SSD’07, 2007, Tunisia, March 19-22
- [8] A. Stoorvogel and A. Saberi and B. M. Chen, “A Reduced order observer base control design for optimization,” IEEE transaction automatic, 1994,
- [9] W. Mieczarski, “Very fast linear and nonlinear observer,” In int. J. control, {1988,
- [10] J. Frederik Hansein and A. K. Adnanes and T. I. Fossen, “Mathematical Modeling of Diesel Electric Propulsion: Systems for Marine Vessels, “ journal Mathematical and Computer Modeling of Dynamical Systems, 2001, vol 7, N °1, pp 1-33,
- [11] E. Benyoussef, A. Meroufel, and S. Barkat, “Three-Level Direct Torque Control Based on Artificial Neural Network of Double Star Synchronous Machine, “ Leonardo Journal of Sciences. 2014, pp 15-27
- [12] S. Kallio, “Modeling and parameter estimation of double-star permanent magnet synchronous machines,” Thesis ,University of Technology, Lappeenranta, Finland on the 5th of March, 2014,
- [13] B. Naas, L. Nezli, M. Elbar and B. Naas, “Direct Torque Control of Double Star Synchronous Machine,” Int. J. of Recent Trends in Engineering and Technology, Vol. 2, No. 5, Nov 2009
- [14] M. Ababneh, M. Salaha and K. Alwidyana,”Linearization of Nonlinear Dynamical Systems: A Comparative Study,” Journal of Mechanical and Industrial Engineering. Jordon 2011.
- [15] S. Vaidyanathan and K. Rajagopal, “Analysis, control, synchronization and LabVIEW implementation of a seven-term novel chaotic system,” *International Journal of Control Theory and Applications*, **9** (1), 151-174, 2016.
- [16] S. Vaidyanathan and A. Boulkroune, “A novel hyperchaotic system with two quadratic nonlinearities, its analysis and synchronization via integral sliding mode control,” *International Journal of Control Theory and Applications*, **9** (1), 321-337, 2016.
- [17] S. Vaidyanathan, “Mathematical analysis, adaptive control and synchronization of a ten-term novel three-scroll chaotic system with four quadratic nonlinearities,” *International Journal of Control Theory and Applications*, **9** (1), 1-20, 2016.
- [18] V. Sundarapandian, “Exponential observer design for nonlinear systems with real parametric uncertainty”, *Mathematical and Computer Modelling*, **37** (1-2), 177-190, 2003.
- [19] V. Sundarapandian, “New results and examples on observer design of nonlinear systems around equilibria,” *Mathematical and Computer Modelling*, **40** (5-6), 657-665, 2004.
- [20] V. Sundarapandian, “Local observer design for nonlinear systems”, *Mathematical and Computer Modelling*, **35** (1-2), 25-36, 2001.