

Development of Stair Climbing Intelligent Wheelchair for Physically Disabled People

B.G. Siva Kumar* and K. Sudhagar**

ABSTRACT

This work deals with a development of stair climbing intelligent wheelchair controls using voice, joystick and navigation. The usage of Design and development of stair climbing intelligent wheelchair helps to overcome the challenged faced by physically challenged person. The development of stair climbing intelligent wheelchair used to monitor and control the system of ATMEGA 328 Microcontroller has been employed. The obstacle detection avoidance is done by sensor unit. It proposed the framework for design and implementing the stair climbing intelligent wheelchair control program is easily performed for other robotic platforms. Stair Climbing Intelligent Wheelchair is used to equipped with a set of sensor such as Infrared sensors and Ultrasonic sensors. In the recent technologies of automation is apparently can applied in the ser-vice robots for future development. The previous work of Intelligent Wheelchair lack of automation within them. This work use to overcome the difficulties of manual wheelchair system.

Keywords: Microcontroller, Intelligent controller, IR sensors and Ultrasonic sensors.

1. INTRODUCTION

“World report on disability” (2011) [3] jointly presented by World Health Organization (WHO) and World Bank says that there are 70 million people are handicapped in the world. Unfortunately day by day the number of handi-capped people is going on increasing due to road accidents as well as disease like paralysis, leprosy and low motor neuron lesions. Wheelchairs are useful for handicapped people who are not able to operate to use conventional wheelchairs. One of the features of intelligent wheelchairs moves with the use of navigational intelligence and voice commands.

1.1. Statistics of Disability in India

We know that every second the population of the World as well as India is increasing rapidly. In India 120 million people are disabled out of which 41.32% are physically disabled. [4].The number of physically disabled people is continuously increasing due to reasons like accidents and diseases like paralysis, leprosy and low motor neuron lesions. The graphical representation of disability in India is shown in figure 1. The statistics is given below in per-centage out of 120 million people.

Physical Disability 41.32%, Locomotor Disability 23.04%, Overlapping 11.54%, Visual Impairment 10.32%, Hearing Impairment 8.36%, Speech Disability 5.06%.

In our state of Tamilnadu which has suffered from number of disabled people in females than males. The population of India was suffering from seeing, hearing, speech, movement, mental retardation, mental illness and multiple disabilities. The wheelchair is used for many of the people who are physically disabled, low motor neuron lesions, paralysis patients. The Wheelchair is an useful device for society and will be very much useful for the physically disabled persons so as to enable them to reach the required places without assistance of others.

* Research Scholar, Dept.of Mechanical Engineering, Bharath University, Chennai, India, Email: sivakumarbg@yahoo.in

** Principal, Murugappa Polytechnic College, Chennai, India, Email: sudhagarks@gmail.com

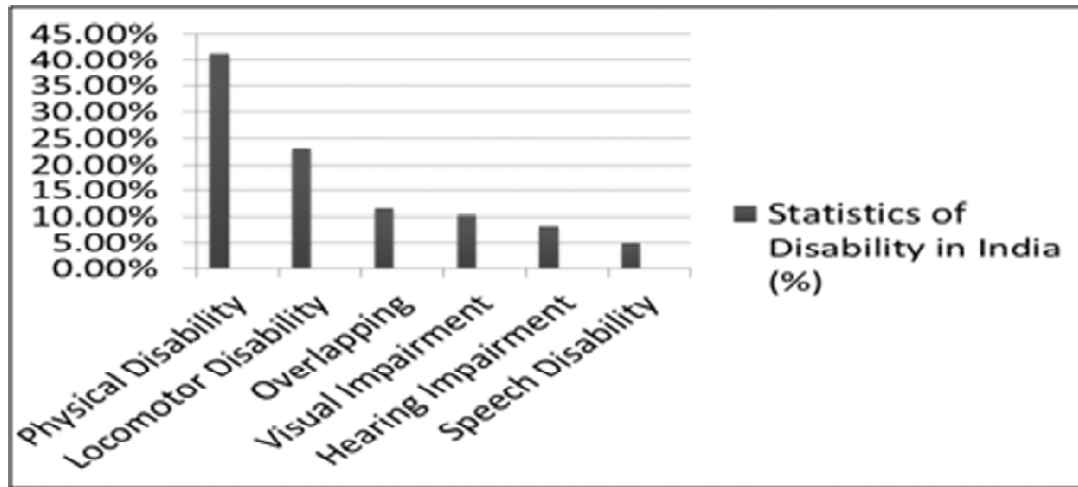

Figure 1: Statistics of Disability in India.

1.2. Problem Definition

Today’s society is more and more people suffered from physical disabled people in India. Census of India 2001 has revealed that over 21 million people in India as suffering from one or the other kind of disability.

Table: 1
Disable population in India: 2011

Type of Disability	Persons	Males	Females
Total	100.0	100.0	100.0
Seeing	18.8	17.6	20.2
Hearing	18.9	17.9	20.2
Speech	7.5	7.5	7.4
Movement	20.3	22.5	17.5
Mental Retardation	5.6	5.8	5.4
Mental Illness	2.7	2.8	2.6
Any Other	18.4	18.2	18.6
Multiple Disability	7.9	7.8	8.1

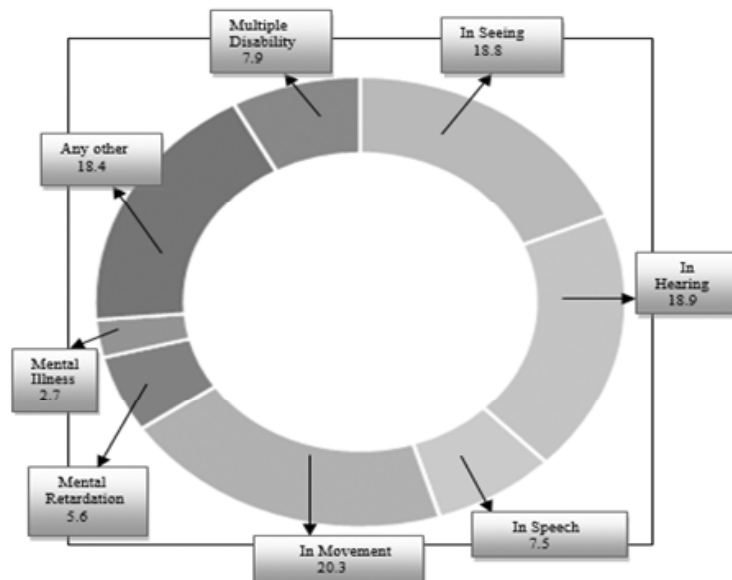

This is equivalent to 2.1% of the population. Among the total disabled in the country, 12.6 million are males and 9.3 million are females. Tamil Nadu is the only state, which has a higher number of disabled females than males. [5].

The main solution of stair climbing intelligent wheelchair extends the capabilities of traditional powered devices by introducing control and navigational intelligence.

2. LITERATURE REVIEW

A. Malik Mohd Ali, Razali Tomari and M. Mahadi Abdul Jamil proposed a system to control the multifinger grippers with significance on the finger tips and finger joints. [1] François Pasteau, Vishnu K. Narayanan and Marie Babel proposed a method for autonomous navigation for an electric wheelchair allows moving corridors and passing through an open door ways.[2]. S.P. Parikh, V. Grassi, V. Kumar and J. Okamoto [6] provides an integral solution to motion planning and control of robotic wheelchairs with human inputs from three sources: at the highest level, the user interacts with the controller to avoid obstacles: and at the lowest level, the human operator directly provides velocity commands using a joy-stick. G. Bourhis, O. Horn, O. Habert and A. Pruski [7] describes a prototype of a robotic wheelchair with manual, semiautonomous and autonomous modes. The choice of mode usually depends on parameters such as single switch or proportional human-machine interface sensors, modeled or non-modeled environment. Benmansour, A. Omari and K. Zemalache discussed a new scheme for an optimal motion planning for golf swing robot using genetic algorithm with B-spline Cubic Uniform approximation [8].

Omranpour and Shiry proposed a new evolutionary algorithm to solve simultaneous localization and mapping issue [9]. M. Balasubramanian, and G. Raja Rajeswari [10] proposed the autonomous mobile robot agents are being developed and deploy in wide range of mission critical application, in which it depends on its navigation from the initial position to target position., in a static or dynamic environment.

Yee-Pien Yang, Ruei-Ming Guan and Yen-Ming Huang [11] proposed a fuel cell power-driven wheelchair determined by rim motors. The wheelchair was light weighted, foldable, fuel efficient and low cost. The hybrid energy wheelchair had a fuel cell with two secondary battery storage packs which can work in enough power. An automated wheelchair designed was designed by M. AL-Rousan et al. The wheelchair movement was guarded by joystick, SMS and voice command. The wheelchair speed was controlled by two buttons. The neural network and wavelets were used to recognize the voice commands.[12,18]

3. HARDWARE DESIGN OF STAIR CLIMBING INTELLIGENT WHEELCHAIR

The hardware design of stair climbing intelligent wheelchair prototype is shown in Figure 2. The main solution of stair climbing intelligent wheelchair extends the capabilities of traditional powered devices by introducing control and navigational intelligence.

The Powered Wheelchair has following features: Two differential driven rear wheels; Two 12 V Lead-Acid Battery 7Ah; Traditional Joystick; Power Module. The Wheelchair hardware parts are divided into three functional blocks: user inputs, Sensor, hardware devices is shown in Fig.3.

3.1. User Inputs

To enable people with different kinds of disabilities such as leprosy, paralysis and low motor neuron lesions. These kind of disabilities person as enable to drive the wheelchair without assistance of others. The idea of this project is very useful for society and will be very much useful for the physically disabled persons so as to enable them to reach the required places without helping of others.

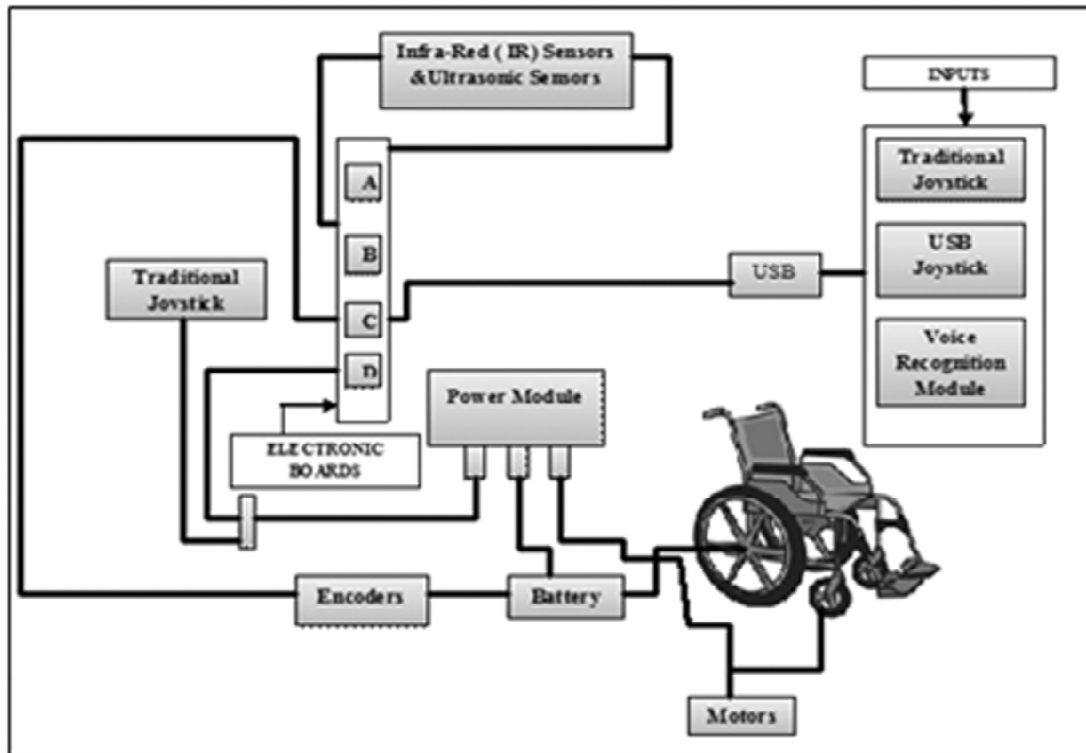

Figure 2: Hardware Design of Stair Climbing Intelligent Wheelchair

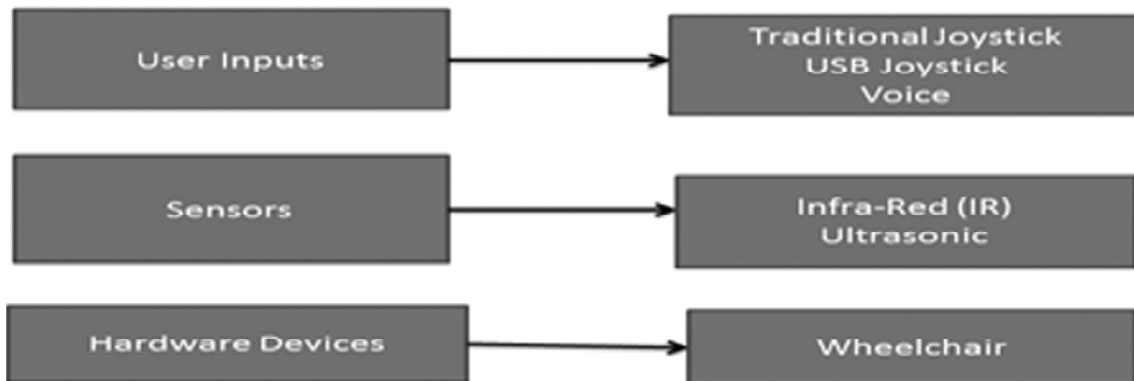

Figure 3: Hardware Functional Blocks

3.1.1. Traditional Joystick

These inputs present in normal wheelchair are a strongest way to drive a wheelchair. These traditional joysticks may not be accessible to paraplegic and cerebral palsy patients.

3.1.2. USB Joystick

The USB joysticks are a little bit simpler than traditional joystick.

3.1.3. Voice

In voice commands we can use commercial software of voice recognition can be developed the necessary conditions and applications to command the wheelchair using the voice as an input.

3.2. Sensor

The purpose of this project to develop a wheelchair. To compose the wheelchair has ten infra-red sensors and four ultrasonic sensors were mounted. Two encoders were assembled on the wheels.

3.3. Hardware Devices

The hardware device block is composed of ultrasonic sensors and infra-red sensors. The function of electronic boards are receiving information from ultrasonic sensors and infra-red sensors are sending information to the microcontroller.

4. DESIGN OF SOFTWARE

The design of the software using solid works. It presents the prototype implementation of intelligent wheelchair. In fig. 4 shows the mechanical structure and the hardware implementation of wheelchair using solid works. Wheelchair extends the capabilities of traditional powered devices by introducing control and navigational intelligence.

5. PATH PLANNING OF STAIR CLIMBING INTELLIGENT WHEELCHAIR

The path planning of stair climbing intelligent wheelchair is shown in fig. 5.

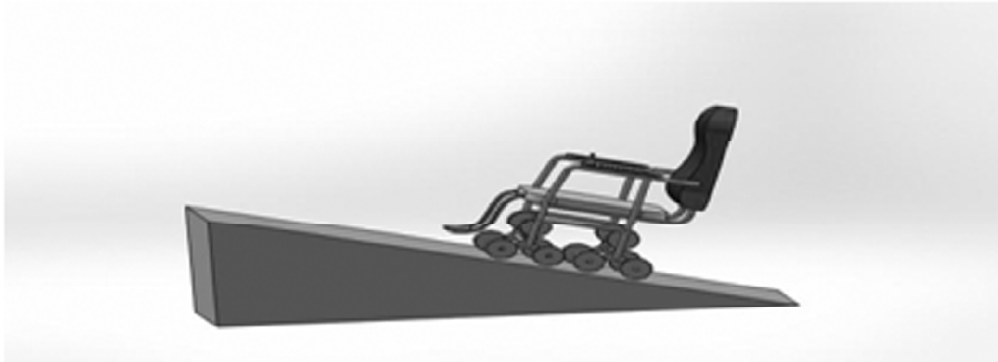

Figure 4: Design Model of Stair Climbing Intelligent Wheelchair

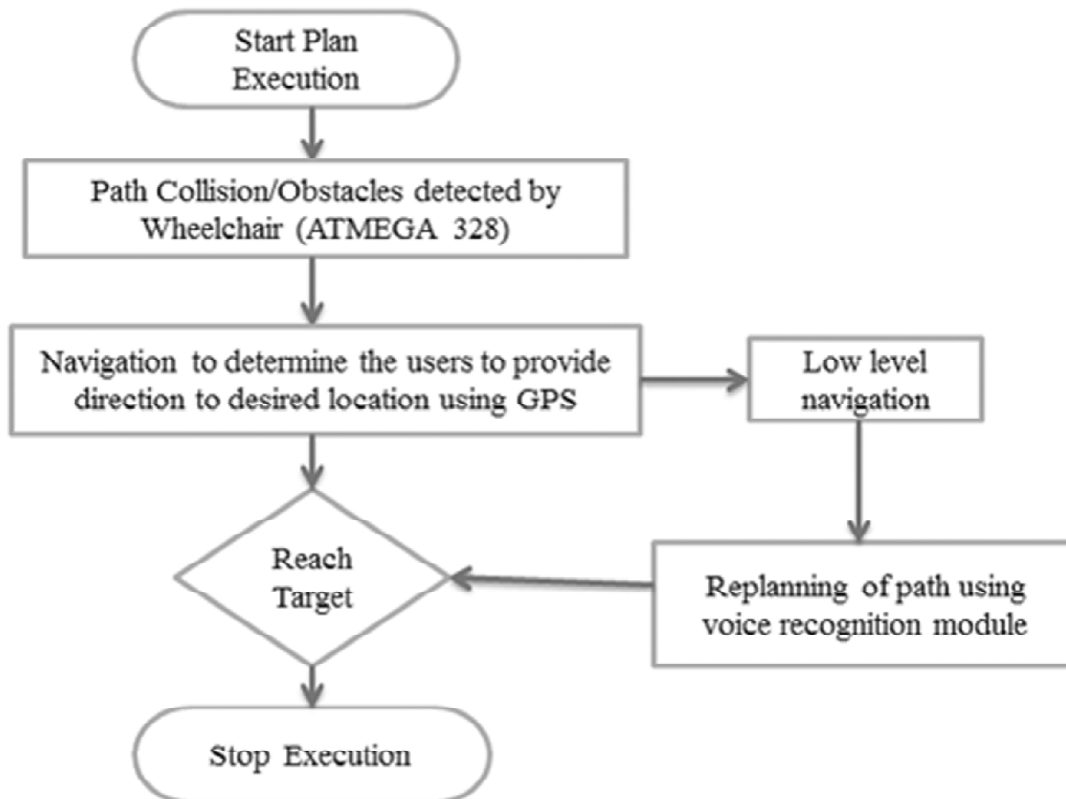

Figure 5: Path Planning of Stair Climbing Intelligent Wheelchair

The ATMEGA328 microcontroller starts execute the navigational plans and continuously sense the obstacles can be detected through sensors. The wheelchair operator will use the touch screen to select the destination. If low network i.e. no signal in network appears, it goes to re planning the path using voice recognition module. The Wheelchair is an useful device for society and will be very much useful for the physically disabled persons so as to enable them to reach the required places without assistance of others.

6. PROPOSED MODEL

The proposed model is shown in fig.6.

The block diagram consists of Ultrasonic sensor, infra-red sensor and motor driver. The sensors are provided for detecting the obstacle.

6.1. Microcontroller Unit

The microcontroller used in this design is ATMEGA 328. It is a single chip micro-controller created by Atmel and belongs to the mega AVR series is shown in fig. 7.

The high-performance Atmel 8-bit AVR RISC-based microcontroller combines 32KB ISP flash memory with read-while-write capabilities, 1KB EEPROM, 2KB SRAM, 23 general purpose I/O lines, 32 general purpose working registers, three flexible timer/counters with compare modes, internal and external interrupts, serial programmable USART, a byte-oriented 2-wire serial interface, SPI serial port, 6-channel 10-bit A/D converter (8-channels in TQFP and QFN/MLF packages), programmable watchdog timer with internal oscillator, and five software selectable power saving modes. The device operates between 1.8-5.5 volts.

6.2. Motor Driver

The motor driver L293D is shown in fig.8. L293D is a dual H-bridge motor driver integrated circuit (IC). Motor drivers act as current amplifiers since they take a low-current control signal and provide a higher-current signal. This higher current signal is used to drive the motors. The motor operations of two motors can be controlled by input logic at pins 2 & 7 and 10 & 15. Input logic 00 or 11 will stop the corresponding motor.

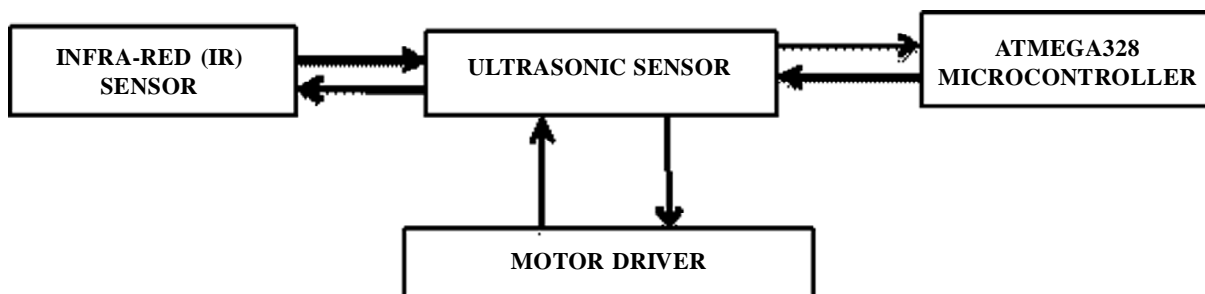

Figure 6: Block Diagram of Obstacle and Track Detection



Figure 7: ATMEGA 328 Microcontroller

Logic 01 and 10 will rotate it in clockwise and anticlockwise directions, respectively. Enable pins 1 and 9 (corresponding to the two motors) must be high for motors to start operating. When an enable input is high, the associated driver gets enabled. As a result, the outputs become active and work in phase with their inputs. Similarly, when the enable input is low, that driver is disabled, and their outputs are off and in the high-impedance state.

6.3. Voice Recognition Module

In voice commands we can use commercial software of voice recognition can be developed the necessary conditions and applications to command the wheelchair using the voice as an input.

7. EXPERIMENTAL SETUP

This section presents the prototype implementation and a simple experiment is shown in fig. 9.

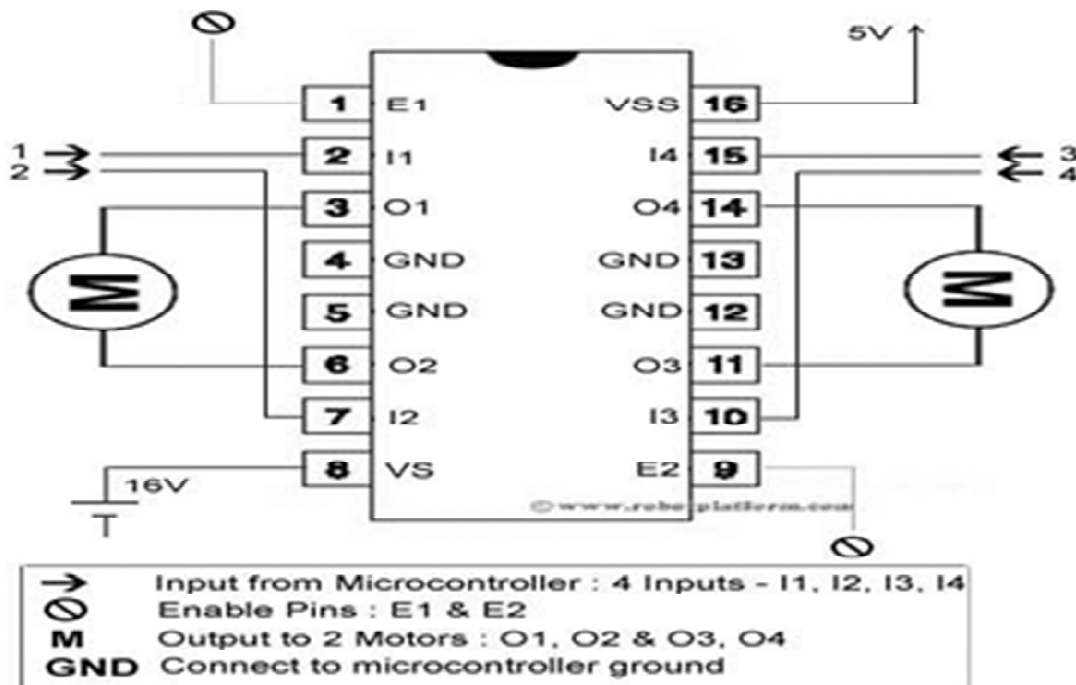

Figure 8: L293D Motor Driver

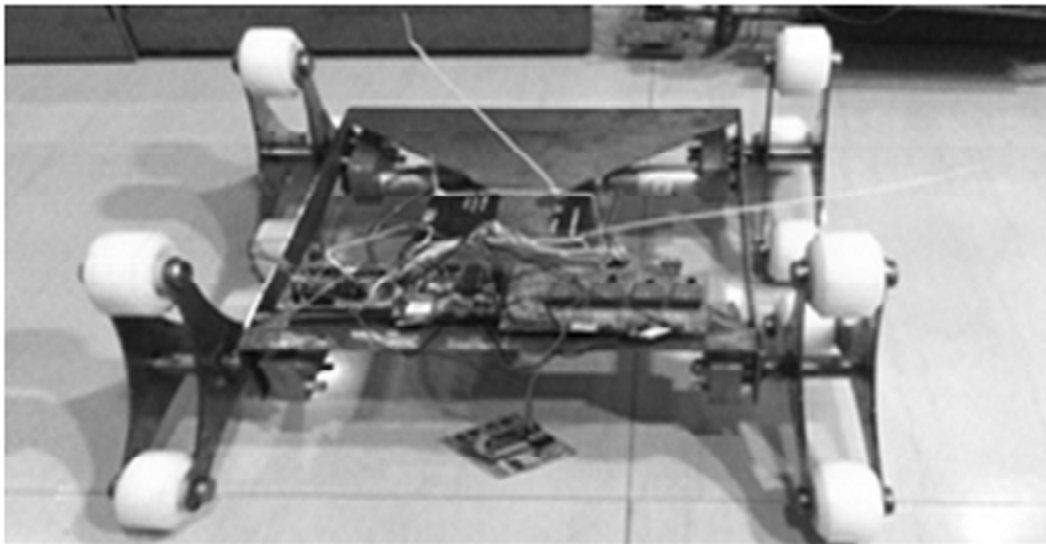

Figure 9: Experimental Structure

It shows the mechanical structure of the hardware implementation of stair climbing vehicle. Low Motor Neuron lesions (LMN), Leprosy patients and Paraplegic/Paraparesis. These implications caused by diseases affect several millions of people. They feel that they are always dependent to others. This platform is designed for stair climbing vehicle should be designed for implementing the wheelchair model. Wheelchair is able to navigate for both indoor and outdoor environments. The Wheelchair extends the capabilities of traditional powered devices by introducing control and navigational intelligence.

8. FUTURE WORKS

The wheelchair is used for physically disabled persons. The wheelchair is controlled by three ways: Navigation, Voice and joystick. Work is continuing towards the goal of an implementing the wheelchair. In this project can locate the topology maps to determine the location of destination points for future works. The intelligent robotic wheelchair will continue to take high-level directional commands from the user and execute them to keeping the users safe. The intelligent wheelchair will automatically run the wheelchair to select the destination to reach the target. The Wheelchair is an useful device for society and will be very much useful for the physically disabled persons so as to enable them to reach the required places without helping of others.

9. CONCLUSION

This paper presents the design and development platform for Wheelchair. This platform facilitates the development of wheelchair for future works. We believe that new technologies can bring the wheelchair for real capacities of planning, autonomous navigation to allow in a semi-autonomous way of the user expressed in high-level language of commands. This paper presents the design and development of intelligent wheelchair for physically disabled people. The Intelligent wheelchair vehicle is used for many of the people who are physically disabled, low motor neuron lesions, paralysis and paraparesis patients. The Intelligent Wheelchair is an useful device for society and will be very much useful for the physically disabled persons so as to enable them to reach the required places without assistance of others.

REFERENCES

- [1] A. Malik Mohd Ali, Razali Tomari and M. Mahadi Abdul Jamil, "An Empirical Framework for Controlling Artificial Hand Grip-per System Using Smart Glove", *Procedia Computer Science*, Volume 42, 2014, Pages 38-45.
- [2] François Pasteau, Vishnu K. Narayanan and Marie Babel, "A visual servoing approach for autonomous corridor following and doorway passing in a wheelchair", *Robotics and Autonomous Systems*, 30 October 2014.
- [3] http://www.who.int/mediacentre/news/notes/2013/disability_and_development_20130920/en.
- [4] <http://www.indiability.org/resources/disability-in-india>.
- [5] http://censusindia.gov.in/Census_And_You/area_and_population.aspx.
- [6] S.P. Parikh, V. Grassi, V. Kumar and J. Okamoto, "Integrating human inputs with autonomous behaviours on an intelligent wheel-chair platform," *IEEEIntell. Syst.*, 22: 33-41, 2007.
- [7] G. Bourhis, O. Horn, O. Habert and A. Pruski, "An autonomous vehicle for people with motor disabilities," *IEEE Robot. Au-tom.Mag.*, 8:20-28, 2001.
- [8] Aboura, S.B., Omari, A., and Meguenni, K.Z., Motion planning and Control of hyper dynamic robot arm, (2014) *International Review of Automatic Control (IREACO)*, 7(1), pp. 82-89.
- [9] H. Omranpour and S. Shiry, "Reduced Search Space Algorithm for Simultaneous Localization and Mapping in Mobile Robots." *International Journal of Robotics and Automation (IJRA)*, Vol. 1, No. 1, March 2012, pp. 49-63.
- [10] M. Balasubramanian, and G. Raja Rajeswari, "A Study on seamless information sharing between robots in identifying the optimal path: An agent based approach", *Proc. of Int. Conf, on Advances in Communication, Network and Computing*, Elsevier Publica-tion, CNC 2014, INDIA.
- [11] Yee-Pien Yang, Ruei-Ming Guan and Yen-Ming Huang, "Hybrid fuel cell powertrain for a powered wheelchair driven by rim motors", *Journal of Power Sources*, pp. 192-204, 2012.

-
- [12] M.AL-Rousan and K. Assaleh, "A wavelet and neural network based voice system for a smart wheelchair control", *Journal of the Franklin Institute* 348, pp. 90-100, 2009.
 - [13] A. Rezoug, M. S. Djouadi, Visual Based Lane Following for Non-holonomic Mobile Robot, *IEEE EUROCON*, 09, pages 902-907, 2009.
 - [14] R. Morales, J. Chocoteco, Obstacle surpassing and posture control of a stair-climbing robotic mechanism, *Control Engineering Practice*, Volume 21, Issue 5, May 2013, pp. 604-621.
 - [15] S. Khusheef, G. Kothapalli, Simulation of a mobile robot navigation system, presented at the 19th International Congress on Modeling and Simulation, pages 318-323, Perth, Australia, December 2011.
 - [16] R. Martinez, A. Rodriguez, "Fuzzy Logic Controllers Optimization Using Genetic Algorithms and Particle Swarm Optimization, in *Proceedings of the 9th Mexican International Conference on Artificial Intelligence*, pp. 475-486, 2010.
 - [17] Andrew Szeto, *Rehabilitation engineering is the application of science and technology to ameliorate the handicaps of individuals with disabilities Introduction to Biomedical engineering*, (Second Edition), 2005, pp. 211-254.
 - [18] Ramesh GP, Aravind CV, Rajparthiban R, N. Soysa, "A Body Area Network through Wireless Technology", *International Journal of Computer Science and Engineering Communications*. Vol. 2, Issue 4, August 2014, pp. 432-437.