



International Journal of Control Theory and Applications

ISSN : 0974-5572

© International Science Press

Volume 9 • Number 49 • 2016

A Review Analysis of Offshore Wind Power Transmission using Fractional Frequency AC System

Seetha Chaithanya*, V. Naga Bhaskar Reddy** and R. Kiranmayi***

* Research Scholar, Department of Electrical & Electronics Engineering, JNT University Anantapur, Anantapur, Andhra Pradesh, India, E-mail: seethachaithu@ieee.org

** Professor & Head, Department of Electrical & Electronics Engineering, Rajeev Gandhi Memorial College of Engineering & Technology, Nandyal, Andhra Pradesh, India

*** Professor & Head, Department of Electrical & Electronics Engineering, JNT University Anantapur, Anantapur, Andhra Pradesh, India

Abstract: The growing use of wind energy conversion system (WECS) especially offshore generations around the world are becoming higher, where the installation, maintenance and transmission power are critical issues. This manuscript presents a novel technology, i.e., Fractional Frequency AC Transmission System (FF-ACTS) e.g. 50/3Hz or 60/3Hz, to integrate the MegaWatt (MW) Offshore wind power system and grid through frequency converter by modeling & simulation. FF-ACTS increases the transmission length, capacity and installation cost compared to existing AC and HVDC systems. A model (simulation) of 180MW wind farm integration via FF-ACTS have been developed, which includes modeling & design. The proposed results are describing the behavior of system with the help of Matlab/Simulink.

Keywords: Offshore Wind Farm, Fractional Frequency AC Transmission System (FF-ACTS), Frequency Converter, Total Harmonic Distortion (THD).

I. INTRODUCTION

As it is known that only 1/3rd of earth is with the land and shortage of space is most challenging factor for erecting electrical generation power plant to meet the power demand of developing nations and Not In My Back Yard (NIMBY) opposition to construction is usually much weaker, although are expensive. In most of countries, e.g., the German government planned to install 25000MW of offshore wind farms by 2030 [1]. In this regard, offshore wind power is the promising solution to this issue. The following factors are essential for installing and maintenance of offshore wind farm. They are such as, adopted generators with control, design and operation of offshore substation, transmission techniques, converter topologies, integration to grid and grid connection issues. Currently, High Voltage AC (HVAC) and High voltage DC (HVDC) Transmissions are known [2].

HVAC is one of the existing technologies for offshore wind plant integration because of its cheap price [3]. However, underwater cables have considerable higher capacitance. As a result the charging current (I_c) is very

huge in HVAC underwater cables, which will cause heavy power loss. As the distance of transmission increases, the active power will become zero. Therefore, the HVAC solution is less suitable for wind farms far from the coast. Another, promising solutions are Line commutated (LC) and Voltage Source Converter (VSC) based HVDC [4].

The LC HVDC connection is advantageous because of reliability. But it has limitations, e.g. it consumes reactive power from the AC grid [5]. In long offshore wind farms VSC-HVDC system is the possible solution. However, costly converters at two ends of the line, mainly in case of the offshore converter grid, which will raise the installations & cost [7]. Another disadvantage in LC and VSC-HVDC technology is charge accumulation of the underwater cable because of DC [6]. As per the above limitations of both transmission systems for long distance offshore wind farm integration, a new technology is Fractional Frequency AC Transmission System (FF-ACTS) [8],[9] is proposed in this paper.

In Fig.1 the line diagram models of the transmission systems are represented. Many pros are observed in the FF-ACTS. The capacity and distance of FF-ACTS is significantly upgraded. The installation cost of the FF-ACTS is less expensive than the VSC-HVDC technology and the operation & maintenance (O&M) cost is reduced to medium distance. Meanwhile, in between the FF-ACTS and the main onshore grid, the frequency converter is to synchronize the frequency. The extra benefits of FF-ACTS are e.g. enhanced voltage stability and zero charge accumulation.

This manuscript is organized as follows: Section II outlines the wind turbine and wind generator modeling. Section III explores the principal & configuration of FF-ACTS. Section IV investigates the simulation of the system with results and Section V concludes the manuscript.

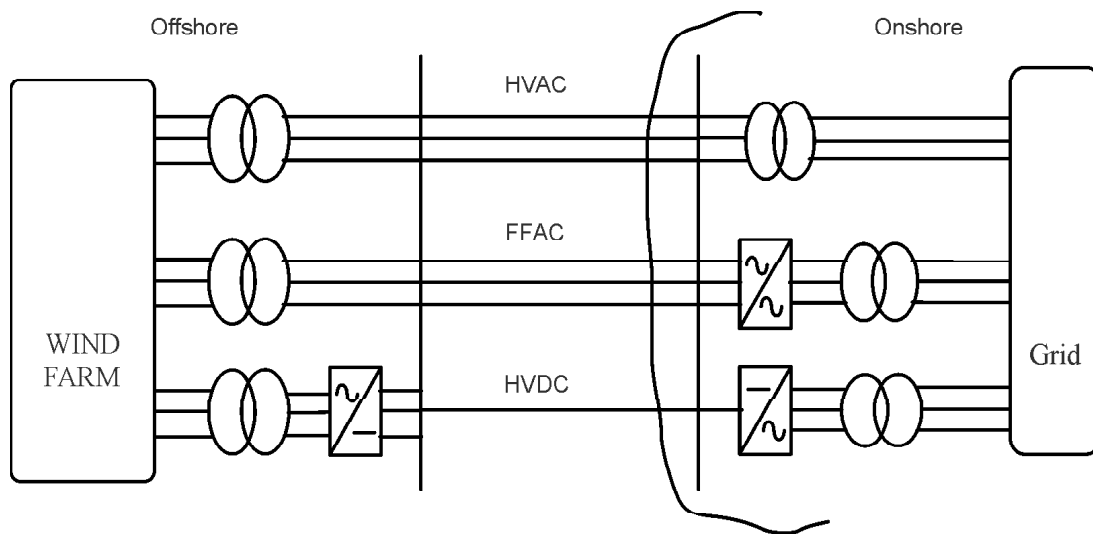

Figure 1: The line diagram of three different transmission technologies [10]

II. MODELING OF WIND SYSTEM

(A) Wind Turbine

It is well-known that the Wind turbine converts Kinetic Energy (K.E) into mechanical energy from wind and delivered that with a high speed Drive train to the rotor. The generator was driven by the shaft, to induce the electricity. Based on the output power characteristics, the aero turbine was modeled from the equn. (1) [11].

$$P_m = 0.5C_p(\lambda, \beta) \rho A V_w^3 \quad \text{equn. (1)}$$

$$\lambda = (R_{\text{blade}} \omega_r) / V_w \quad \text{equn. (2)}$$

Where P_m equal to the mechanical power output, which changes with respect to co-efficient of performance C_p , density of wind ρ , turbine blades area A and speed of wind V_w . $(\frac{1}{2})\rho A V_w^3$ is K.E of the wind at speed V_w . The K.E captured by the wind turbine system is decided by the coefficient of performance $C_p(\lambda, \beta)$, that is determined by the tip speed ratio and blade pitch angle [11].

$$C_p(\lambda, \beta) = 0.50 * (116.0 / \lambda_i - 0.4 * \beta - 5) * e^{(-21 * 1 / \lambda_i)} \quad \text{equn. (3)}$$

$$\frac{1}{\lambda_i} = \frac{1}{\lambda + 0.08\beta} + \frac{0.035}{\beta^3 + 1} \quad \text{equn. (4)}$$

Where ω_r and R_{blade} are angular velocity and the blade radius of the aero turbine respectively.

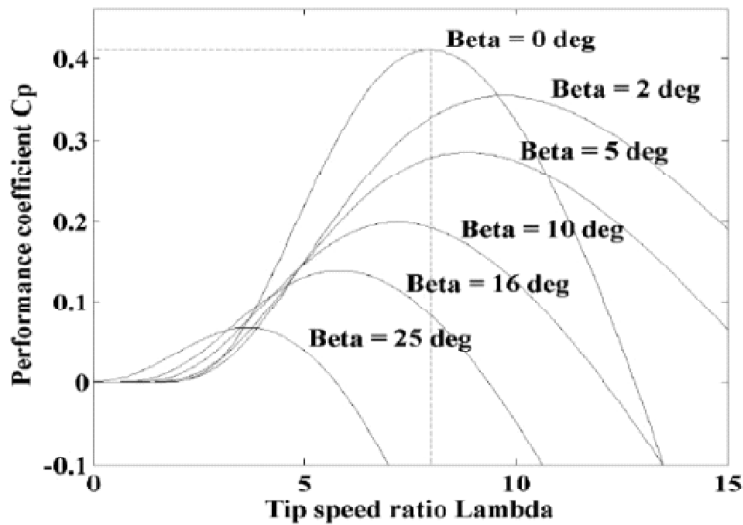

Figure 2: $C_p - \lambda$ characteristics for wind turbine

The $C_p - \lambda$ characteristics are shown in Fig. 2 for the different values of β . From the characteristics the maximum C_p is achieved when $\beta = 0^\circ$ and $\lambda = 8.1$. From equn. (3) and (4) the $C_p - \lambda$ characteristics are fixed, if the blade has a constant geometrical axis. As a result, the turbine output power follows the characteristics of $P_m - \omega_r$. In this manuscript, the aero turbine is modeled for constant $\beta = 0^\circ$ and for wind variations between 6 m/s to 14.4 m/s, the $P_m - \omega_r$ curve is shown in Fig. 3.

(B) Squirrel Cage Induction Generator (SCIG)

The squirrel cage type induction generator state-space equation in d-q reference is as explained in equn. (5).

$$\begin{aligned} V_{ds} &= R_s i_{ds} - \omega_s \Psi_{qs} + \Psi_{ds} \\ V_{qs} &= -R_s i_{qs} - \omega_s \Psi_{ds} + \Psi_{qs} \\ V_{dr} &= 0 = -R_r i_{dr} - s\omega_s \Psi_{qr} + \Psi_{dr} \\ V_{qr} &= 0 = -R_r i_{qr} - s\omega_s \Psi_{dr} + \Psi_{qr} \end{aligned} \quad \text{equn. (5)}$$

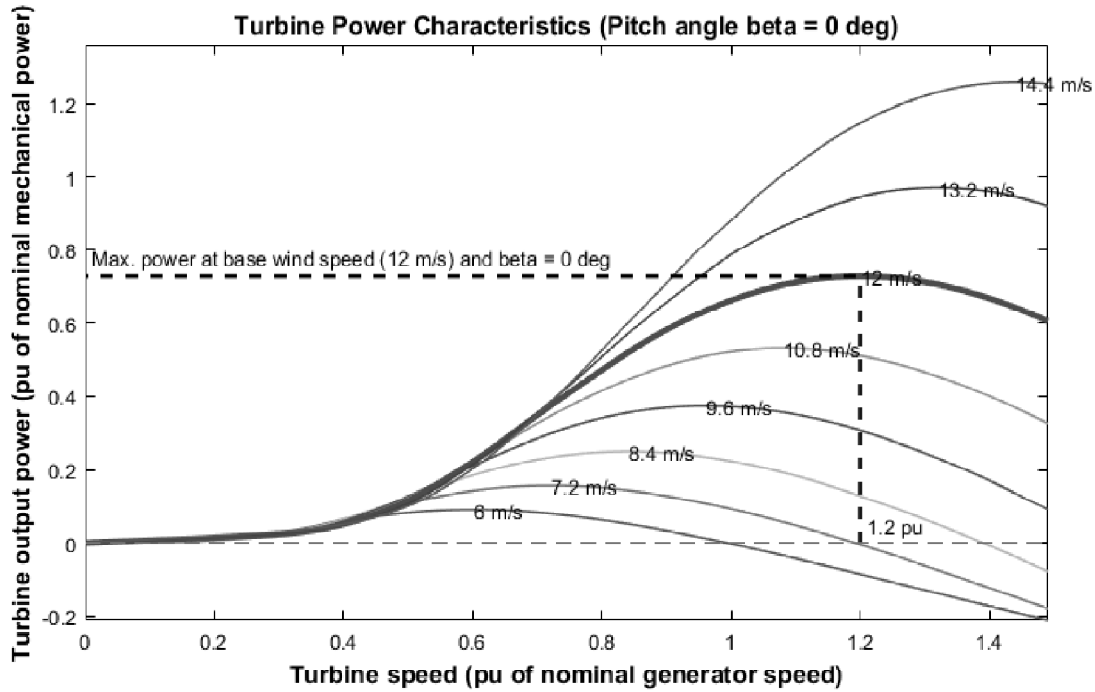

Figure 3: $P_m - \omega_r$ characteristics for wind turbine

With voltage (V), the current (i), resistance (R), stator frequency (electrical) ω_s , the rotor slip (s) and the Ψ be the linkage of flux. The suffixes d & q represents direct & quadrature axes respectively; s & r are represents stator & rotor quantities. Table 1 shows the wind system model parameters.

Table 1
Parameters of Squirrel Cage IG based Wind System

Parameter	Value
Nominal Wind Speed V_w	12 m/s
Rated Active Power P_{nSCIG}	1.5 MW
Rated Grid Voltage V_{grid}	132 kV
Rated Grid Frequency f_{grid}	60 Hz
Wind Turbine Generated Voltage V_{wt}	460 V
Stator Resistance R_s	0.01282 p.u.
Rotor Resistance R_r	0.00702 p.u.
Mutual Inductance L_m	2.503 p.u.
Stator / Rotor Leakage Inductance L_s/L_r	0.05051 p.u.

III. PRINCIPLE AND CONFIGURATION OF FF-ACTS

(A) Principle of FF-ACTS

In Alternating Current transmission configuration the active power transferring over the lines is denoted by P, now the offshore wind farms transmission power stated by the equn. (6)

$$P = \frac{E_s E_r}{X_L} \sin \delta \quad \text{equn. (6)}$$

In the above equation E_s and E_r are the sending & grid end voltages respectively. Line reactance and load angle are denoted by X_L & δ . When the length of the cable is less, thus the effect of line angle will be neglected, then the eqn. (6) is valid [10]. As from eqn. (6) the active power transmission is increased either by enhancing the magnitude of voltage or minimizing the impedance (Z) of underwater cable. Meanwhile, the source and receiving end voltages are constant. The transmission capacity enhancement is possible by decreasing the reactance of the cable if resistance is neglected. The impedance is dominated by the line reactance X_L , and is proportionate with respect to frequency f of line as shown in eqn. (7).

$$X_L = 2\pi fL \tag{7}$$

Transmission capacity would increase by reducing the reactance of the line. To decrease the reactance of the line, the FF-ACTS utilize fractional-frequency. For example, 60/3 Hz frequency is ideally three times of the transmission capacity can be increased.

Furthermore, the FF-ACTS improve the voltage stability of the system and the amount of reactive power transmission as given in eqn. (8) [12].

$$\% \Delta V = (QX/V)*100 \tag{8}$$

With ΔV is the voltage drop & V is the base voltage along the line, Q be the reactive power of the underwater cable. The voltage drop along the line is reduced with the reduction of impedance of FF-ACTS.

(B) Structure of FF-ACTS

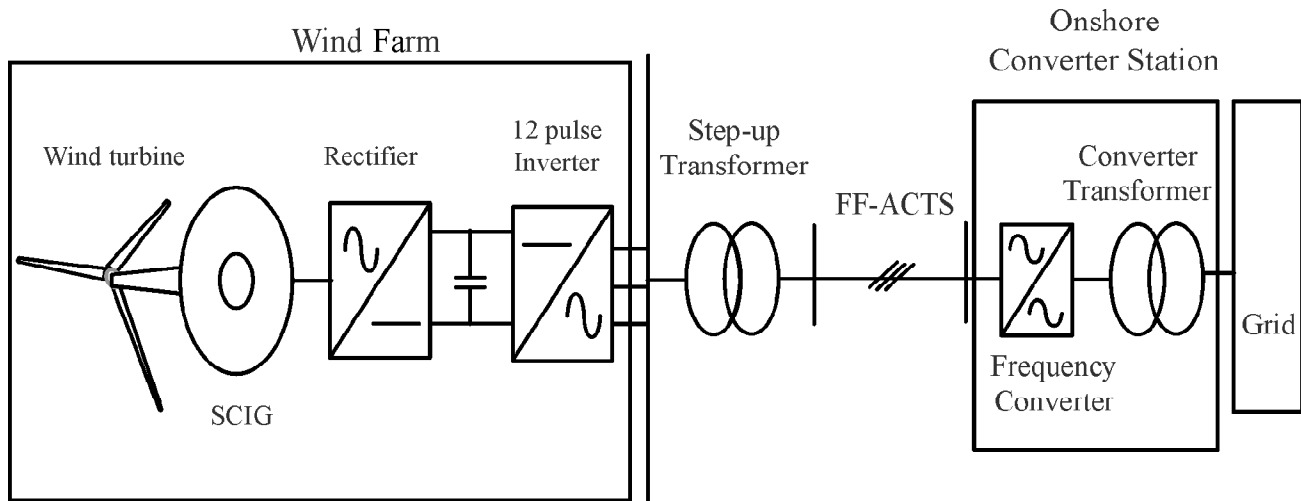

Figure 4: Structure of FF-ACTS

The proposed structure of FF-ACTS is shown in Fig.4. In this, the wind turbine operation is assumed under maximum power point tracking control. By considering the pros of SCIGs e.g. their attraction, robustness and reliability, the fixed speed wind turbine generator was demonstrated in this manuscript. The SCIG based wind farm generates AC power and is rectified by diode rectifier.

At the source end, the offshore grid is 30kV DC collection. The reason behind the offshore DC grid with FF-ACTS is no need to re-construct the wind turbine & generator for fractional frequency AC. The main grid frequency is assumed as 60Hz [6]. A twelve-pulse thyristor-based inverter converts rectified output to the fractional frequency (20-Hz) AC power. Now the low frequency AC power fed to 20Hz phase-shift transformer to increase the voltage level. Here with AC Power transmission carried out at fraction frequency i.e 20 Hz. In order to

mitigate the odd harmonics like 11th, 13th and higher-order current harmonics and to compensate the reactive power to the converter an AC filter is connected at the inverter side.

The proposed FF-ACTS is built with commonly used components in power system. The operation of FF-ACTS is as follows. At first the DC collection system is charged at source end with the generated power from wind turbine generator. On the other hand, the frequency converter at the grid end is activated, and the underwater cables are energized by a fractional frequency voltage (20Hz). At the source end a twelve-pulse inverter can synchronize in between the DC collection system and FF-ACTS with required frequency and voltage.

(C) Frequency Converter

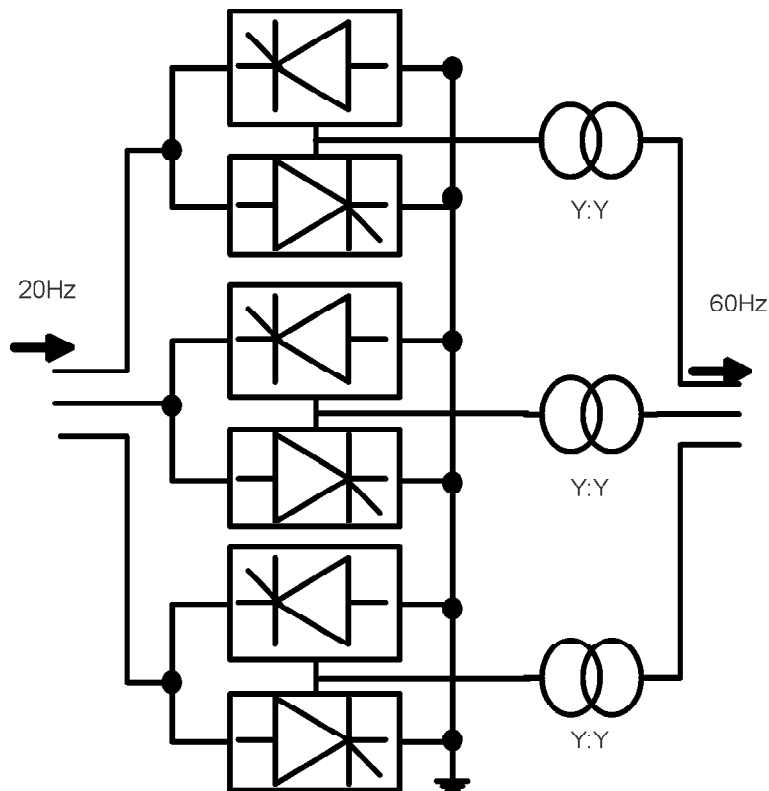

Figure 5: Three-phase 36-pulse frequency converter [13]

Fig. 5 shows the three-phase 36-pulse frequency converter. The frequency converter in the FF-ACTS is a less well known for such an AC to AC application. The thyristor based thirty-six pulse frequency converter converts 20Hz AC to 60Hz AC. The three phase input of 20 Hz wave convert to 60 Hz output, and for each phase of output has a positive and negative six pulse converter. The cosine angle control method is used to control the thyristor firing angle in each converter [6]. The firing pulse generated depending on the output frequency. A filter (LC) is connected at the FF-ACTS side to mitigate the harmonics generated by the frequency tripler.

IV. SIMULATION OF THE SYSTEM & RESULTS

This section illustrates the wind farm connection to grid via FF-ACTS through modeling and simulation. The simulation model was illustrated into two parts. 1) Wind turbine with SCIG 2) proposed FF-ACTS. Fig.6 shows the model of wind turbine with SCIG.

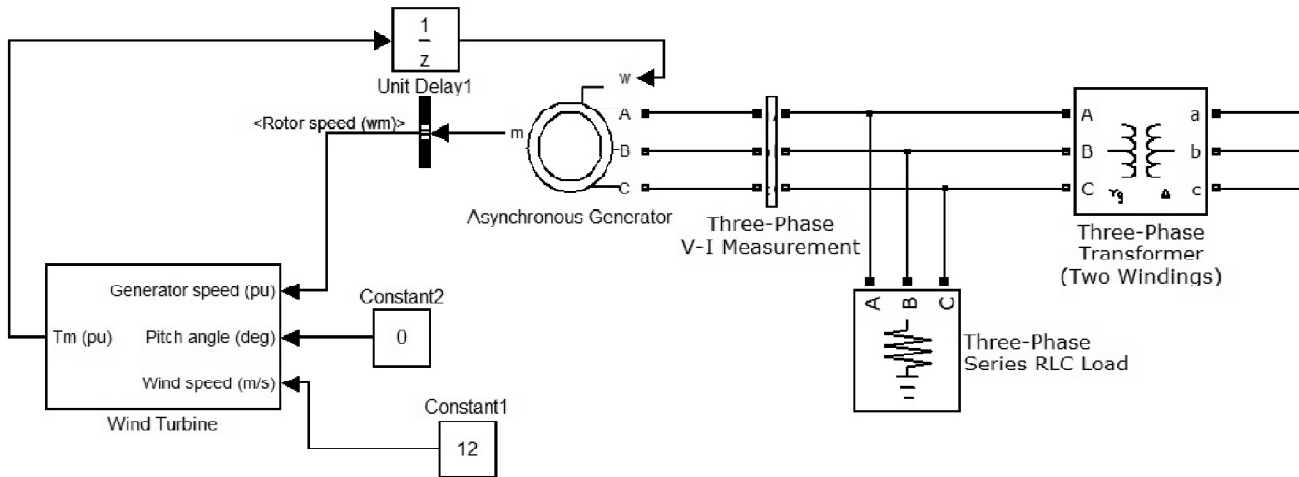

Figure 6: The model of wind turbine with SCIG

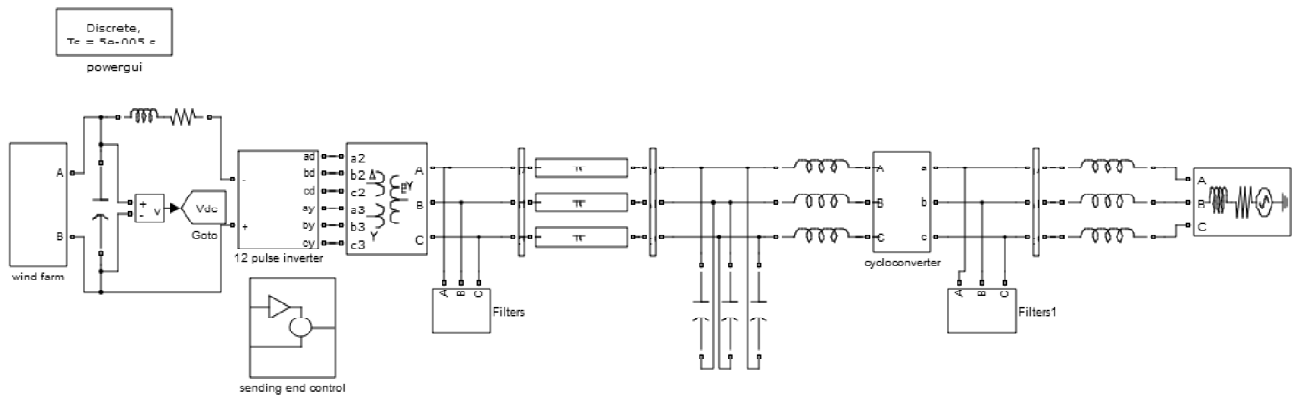
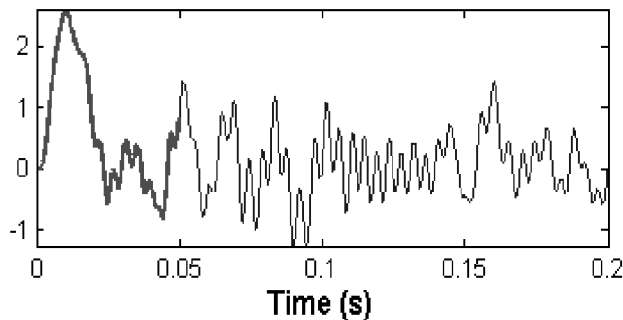

Figure 7: Proposed topology of FF-FACTS

The Fig. 7 shows the proposed topology of FF-FACTS. The Simulation results of 12-Pulse Inverter at sending end and Frequency converter at receiver end are considered for different parameters like voltages, currents and THD values with & without L-C filters are observed by Matlab/Simulink. A 180MW rated wind plant and 160 km line is modeled. Fig.8 depicts the observed sending voltages of FF-FACTS in per units and the THD values without filters is 66.97% and with filters is 2.89%.

Selected signal: 4 cycles. FFT window (in red): 1 cycles



Selected signal: 4 cycles. FFT window (in red): 1 cycles

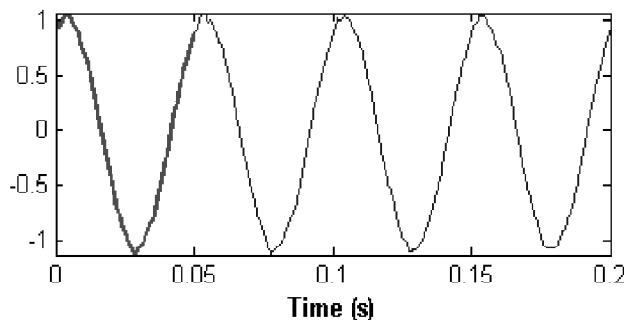

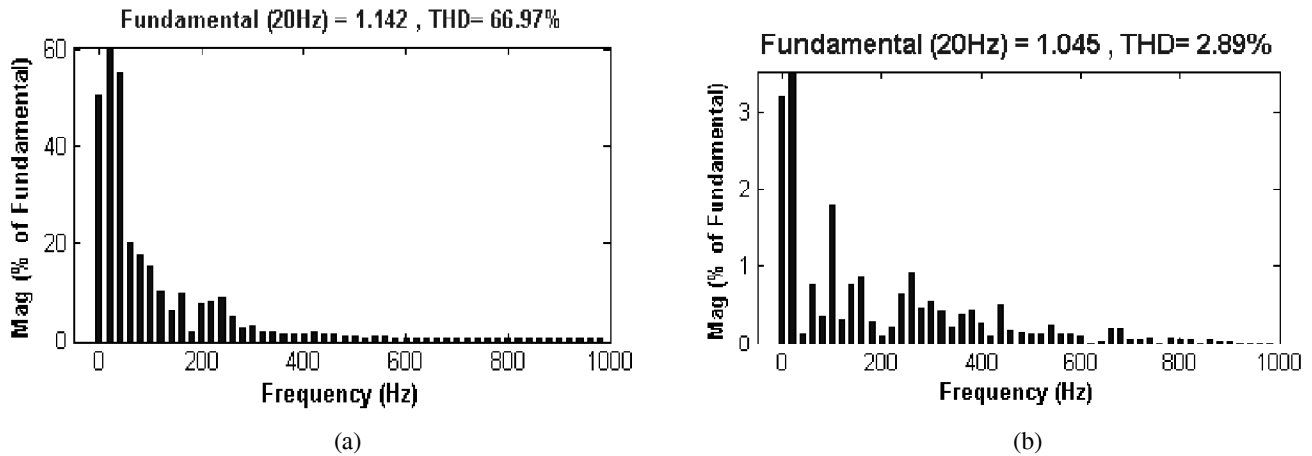
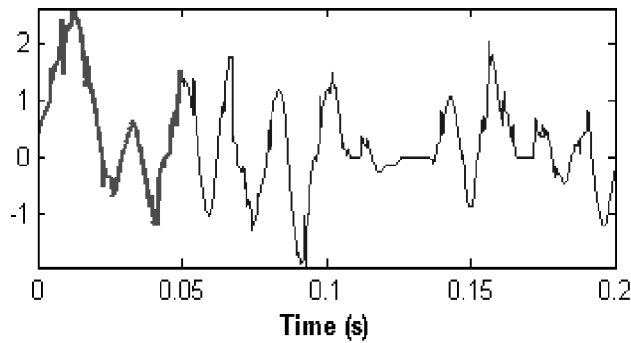

Figure 8: a) Sending end voltage (pu) and THD value of FF-ACTS without filters b) Sending end voltage (pu) and THD value of FF-ACTS with filters

Selected signal: 4 cycles. FFT window (in red): 1 cycles



Selected signal: 4 cycles. FFT window (in red): 1 cycles

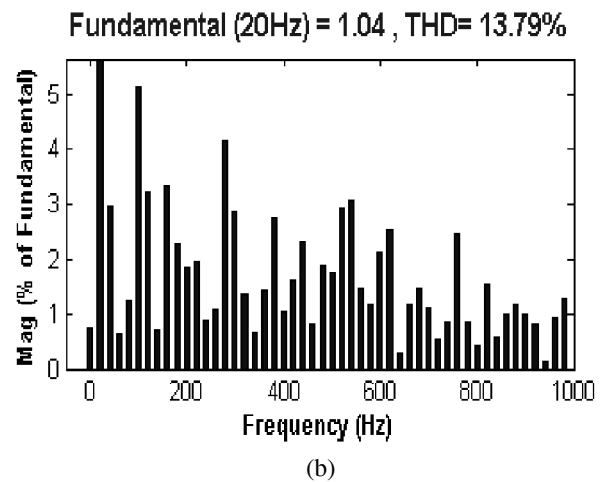
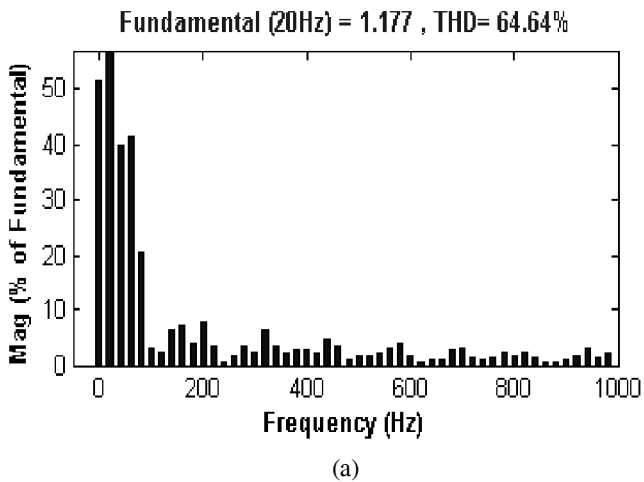
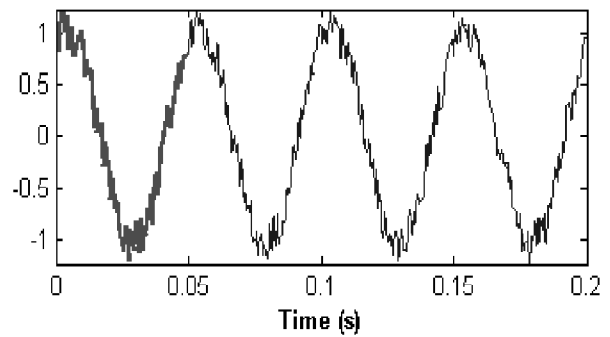

Figure 9: a) Frequency converter voltage (pu) and THD value of FF-ACTS without filters b) Frequency converter voltage (pu) and THD value of FF-ACTS with filters

From Fig.9 it is observed that the voltage at frequency converter is 1.177 per unit and the THD value is 64.64% without filters. If both the filters are connected, the voltage and THD values are 1.04 per unit and 13.79% respectively. Fig.10 shows the simulated voltages and currents at 60Hz onshore grid.

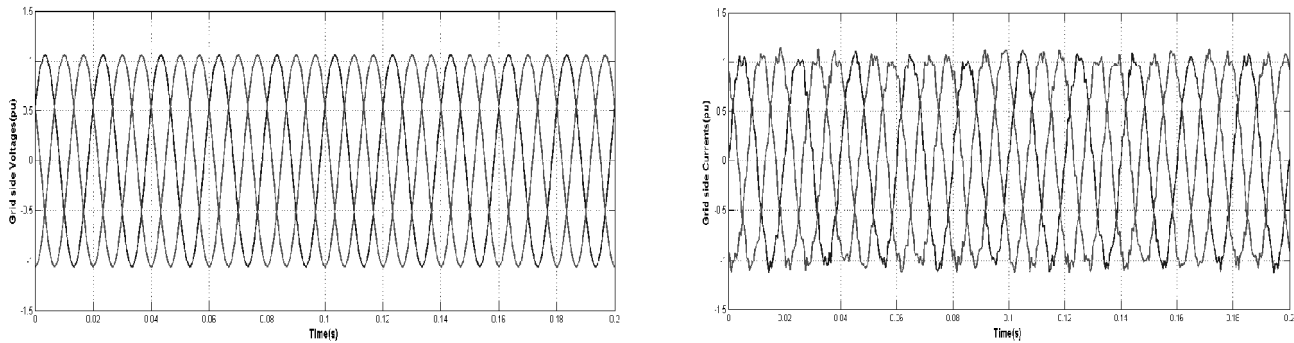

Figure 10: (a) Simulated voltages and (b) Currents at 60Hz onshore grid

V. CONCLUSION

This paper concludes with the results based on the performance of sending end & grid end converters. Performance of converters carried out with the reduction in THD, whereas the existing literature states that the fractional frequency system raises the power transmission capacity. This is the case study on FF-ACTS by the modeling and simulation. The simulation result shows the FF-ACTS increase the transmission capability. Moreover, the FFT analysis shows the harmonics are introduced by the frequency converter. So the harmonics need to mitigate more. The extension of work would concentrate, to improve the FF-ACTS for large scale wind farm system connection to the grid, to enhance the whole system performance, for e.g. designing of filter, modeling of other wind generators with other type of drive trains.

REFERENCES

- [1] EWEA: The European Offshore Wind Industry – Key Trends and Statistics 2012 (European Wind Energy Association, Brussels 2013).
- [2] P. Bresesti, W. L. Kling, R. L. Hendriks, and R. Vailati, “HVDC connection of offshore wind farms to the transmission system,” *IEEE Trans. Energy Convers.*, vol. 22, no. 1, pp. 37–43, Mar. 2007.
- [3] Van Eeckhout, B., et al. “Economic comparison of VSC HVDC and HVAC as transmission system for a 300 MW offshore wind farm.” *European Transactions on Electrical Power* 20.5(2010):661–671.
- [4] Bresesti, P.; Kling, W.L.; Hendriks, R.L.; Vailati, R., “HVDC Connection of Offshore Wind Farms to the Transmission System,”, *IEEE Trans. Energy Conversion*, vol. 22, no.1, pp. 37-43, March 2007.
- [5] S. V. Bozhko, R. Blasco-Giménez, R. Li, J. C. Clare, and G.M.Asher, “Control of offshore DFIG-based wind farm grid with line-commutated HVDC connection,” *IEEE Trans. Energy Convers.*, vol. 22, no. 1, pp. 71–78, Mar. 2007.
- [6] H. Chen, M. Johnson, and D. Aliprantis, “Low-Frequency AC transmission for offshore wind power,” *Power Delivery*, *IEEE Transactions on*, vol. 28, no. 4, pp. 2236–2244, Oct 2013.
- [7] Stefan Lundberg, “Evaluation of Wind Farm Layouts”, Chalmers University of Technology.
- [8] Funaki. T and Matsuura. K, “Basic concept of Low Frequency AC transmission system”, *International Conference on Electrical Engineering (ICEE99)*, Vol. II, pp.17-20, 16-18 Aug, Hong Kong, 1999.
- [9] Funaki. T, Matsuura, K. “Feasibility of the Low Frequency AC transmission”, *Power Engineering Society Winter Meeting*, 2000. *IEEE Volume 4*, 23-27 Jan. 2000 Page: 2693-2698.
- [10] Nan Qin, Shi You, Zhao Xu, “Offshore wind farm connection with low frequency AC transmission technology,” *IEEE Power & Energy Society General Meeting*, 2009. PES '09., 2009, Calgary, AB
- [11] S. Heier, *Grid Integration of Wind Energy Conversion Systems*, John Wiley & Sons, 2006.
- [12] Wang Xifan; Cao Chengjun; Zhou Zhichao, “Experiment on Fractional Frequency Transmission System”, *Power Systems*. *IEEE Transactions on* Volume 21, issue 1, Feb. 2006 Page: 372-377
- [13] J. Ruddy, R. Meere, and T. O’Donnell, “A Comparison of VSC-HVDC with Low Frequency AC for Offshore Wind Farm Design and Interconnection,” in *EERA DeepWind’2015 Deep Sea Offshore Wind R&D Conference*, 04-06 February, 2015.