



International Journal of Control Theory and Applications

ISSN : 0974-5572

© International Science Press

Volume 10 • Number 33 • 2017

Design and Implementation of OFDM Signal Transmission for Visible Light Communication

Sophiya Bartalwar^a and T. Deepa^a

^aDepartment of Telecommunication Engineering, SRM University, 603203

E-mail: sbsbshay5@gmail.com, deepa.t@ktr.srmuniv.ac.in

Abstract: Optical wireless communication (OWC) in the infrared and visible range is quite attractive solution, especially where radio communication face challenges. Visible light communication (VLC) a data communications medium uses visible light (VL) over a range of 400 and 800 THz (780–375 nm) and is a subset of OWC technologies. With an increasing demand for use of wireless communications, wireless access via Wi-Fi is facing many challenges especially in terms of capacity, availability, efficiency and security. Li-Fi uses intensity modulation and direct detection. Therefore, the signals must be strictly real valued and positive. These constraints pose limitation on digital modulation techniques. These limitations result in spectrum-efficiency or power-efficiency losses. In this paper, we investigate an amplitude shift keying (ASK) based orthogonal frequency division multiplexing (OFDM) signal transmission scheme for VLC technology. The ASK technique also works efficiently for transmission of digital data over optical fiber. In this paper, M ary ASK is proposed for use in OFDM systems.

Keywords: –M-ASK, OFDM, OWC, Software Defined Radio, VLC.

1. INTRODUCTION

With an increasing demand for use of wireless communications, wireless access via Wi-Fi is facing many challenges especially in terms of capacity, availability, efficiency and security. Recently, “Li-Fi” was introduced by Harald Hass in 2011 on Visible light communication VLC [1], to overcome those challenges which are faced by Wi-Fi. Li-Fi uses intensity modulation and direct detection. Therefore, the signals must be strictly real valued and positive. These constraints pose limitation on digital modulation techniques. These limitations result in spectrum-efficiency or power-efficiency losses. Visible light communication (VLC) a data communications medium uses visible light (VL) over a range of 400 and 800 THz (780–375 nm) and is a subset of OWC technologies as shown in Fig.1. Development of novel and efficient wireless technologies for a range of transmission links is essential for building future miscellaneous communication networks for providing wide range of services and to satisfy with the ever-increasing demand of achieving higher data rates.[2].

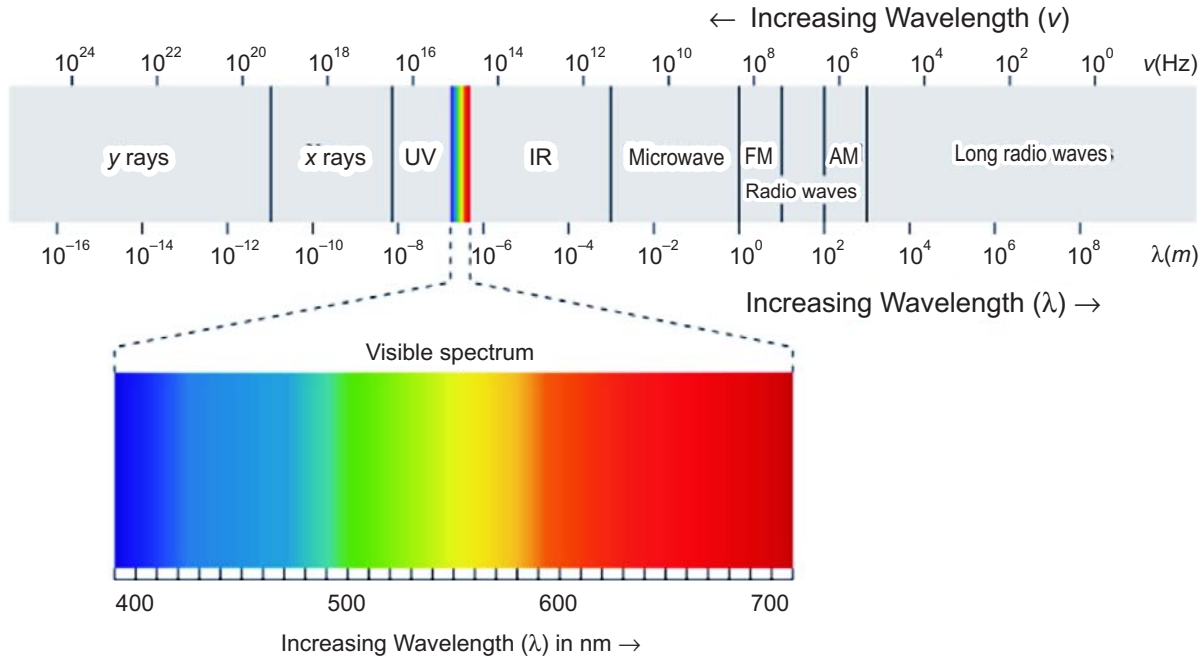

Figure 1: Spectrum Analysis for VLC

Software defined radios (SDRs) approach have been emerged as a viable prototyping option for next generation wireless research by enabling researchers to quickly prototype a system, characterize its performance, on the design. [3]. For flexibility of communication in optical system OOK technique is generally preferred. However it suffers disadvantage of poor bandwidth efficiency and high sensitivity to dispersion for high data rates. Both amplitude and phase modulation renders the prospect of multiple symbol values although the former places challenging demands on laser phase noise. Orthogonal frequency division multiplexing OFDM technique is the most adopted modulation technique, offering many advantages such as high spectral efficiency, noise, inter-symbol interference and multipath robustness and has ability to resist channel fading. [5]. OFDM have been adopted for communication in wireless and wired systems such as: DSL (Digital Subscriber Line) and DVB (Digital Video Broadcasting) systems, PLC (Power Line Communication), WLAN (Wireless LAN), WiMAX (Worldwide Interoperability for Microwave Access), LTE (Long Term Evolution) [6-8]. OFDM is a multicarrier transmission scheme works over a wideband channel consisting of overlapping orthogonal narrowband subcarriers for conveying any sort of information which is parallel in the frequency domain. In this work, Amplitude shift keying (ASK) based OFDM transceiver is implemented using LabVIEW. The traditional theory simulation lacks the interference information of practical channel. This paper, combines the simulation theory and physical research platform to evaluate OFDM link performance using LabVIEW. The remaining section as follows: Section II gives ASK based OFDM scheme using software defined radio platform, system implementation is depicted in Section III and presents the simulation results of OFDM for VLC. The conclusion is present in Section IV.

2. ASK BASED OFDM SCHEME

ASK is a form of amplitude modulation that represents the data in digital form which is obtained by variation in carrier wave amplitude. Here each data bits are assigned a unique pattern of binary digits where each amplitude encodes equal number of bits. Here when the signal value is 1 carrier signal will be transmitted, otherwise signal value 0 will be transmitted.

$$s(t) = \begin{cases} A_0 \cos 2\pi f_c t & \text{binary 0} \\ A_1 \cos 2\pi f_c t & \text{binary 1} \end{cases} \quad (1)$$

The block diagram for ASK based modulator is shown in Fig.2.

Every individual bit pattern forms symbol defined by specific amplitude. Demodulators are basically designed for the symbol-set used by the modulator. These set determines amplitude of the received signal and maps it back to the symbol thus recovers original data. Frequency and phase of the carrier remains unchanged.

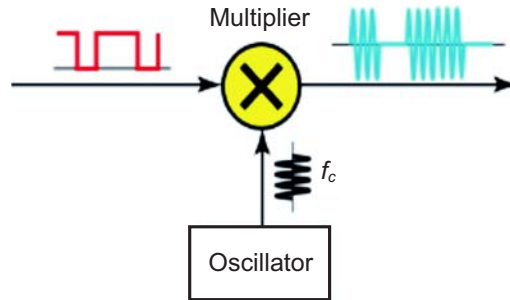

Figure 2: ASK Modulator

Different symbols are assigned with different voltage values. Let the maximum allowed value for the voltage be A, then remaining all possible values will be in the range $[-A, A]$ and given by

$$v_i = \frac{2A}{M-1}m - A$$

$$m = 0, 1, 2, \dots, M-1 \quad (2)$$

The ASK modulation is specified by the relation between the signal levels in on and off states. The difference between one voltage and the other is:

$$\Delta = \frac{2A}{M-1} \quad (3)$$

Format of ASK-based modulation are specified by simple signal generation and detection, due to which all currently established optical transmission systems utilizes ASK modulation format.

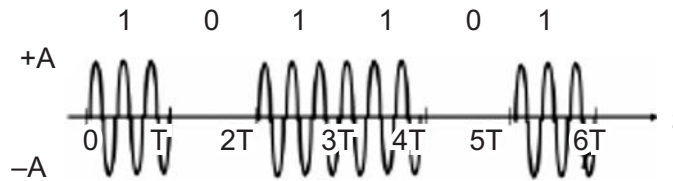

Figure 3: ASK modulated signal waveform

The ASK technique is also commonly used to transmit digital data over optical fiber. For LED transmitters, binary 1 is represented by a short pulse of light and binary 0 by the absence of light. Laser transmitters normally have a fixed “bias” current that causes the device to emit a low level light. This low level represents binary 0, while a higher-amplitude light wave represents binary 1 as shown in Fig. 3.

3. SYSTEM IMPLEMENTATION IN OFDM

The baseband, discrete-time OFDM system model is shown in fig 3. The data symbols are modulated by means of an inverse fast Fourier transform (IFFT) on N parallel subcarriers. A cyclic prefix is added involves the transfer of symbols in their communication preserving orthogonality of subcarriers in OFDM transmission. The resulting OFDM symbol is serially transmitted over a discrete time channel. At the receiver, the data are retrieved by means of a Fast Fourier transform (FFT). An accepted means of avoiding inter-symbol interference (ISI) and preserving orthogonality between subcarriers and append them as a cyclic prefix to form the complete OFDM symbol. The insertion of a cyclic prefix can be shown to result in an equivalent parallel orthogonal channel structure that allows for simple channel estimation and equalization. Finally, the data is being de mapped after a serial conversion and finally retrieved back at the output.

Table 1
Simulation Parameters of OFDM Implementation in LabVIEW

<i>Parameters</i>	<i>Values</i>
Number of bits	10000
Generate random data bits (PN Sequence)	256
Modulation	M-ASK
Order of Modulation, M	16
Map bits to symbols	2
IFFT size	256
Cyclic Prefix size	64
Channel	AWGN
Simulation Tool	LabVIEW

Procedure for Simulation of ASK based OFDM Transmitter:

1. Initialize the number of bits and ASK map locations
2. Generate random data of 10000 bits
3. Map bits to symbols we achieve 2500 symbols
4. Divide the array of symbols into 20 sets of 125 point data sets and build OFDM symbols
5. Insert one of 25 reference symbol after every 21st data symbol 150 pts per OFDM symbol
6. Insert 53 zeroes at the edges of the passband and at 1 zero at DC 256 pts per OFDM symbol
7. Perform an Inverse FFT to convert the frequency domain design to a time domain signal obtaining 256 point IQ time domain waveform
8. Insert a 64 point cyclic prefix by duplicating the last 64 points of the array at the beginning resulting in 320 point IQ time domain waveform
9. Generate frequency representation of OFDM signal.
10. Push the data to a data queue to be shared with the receiver

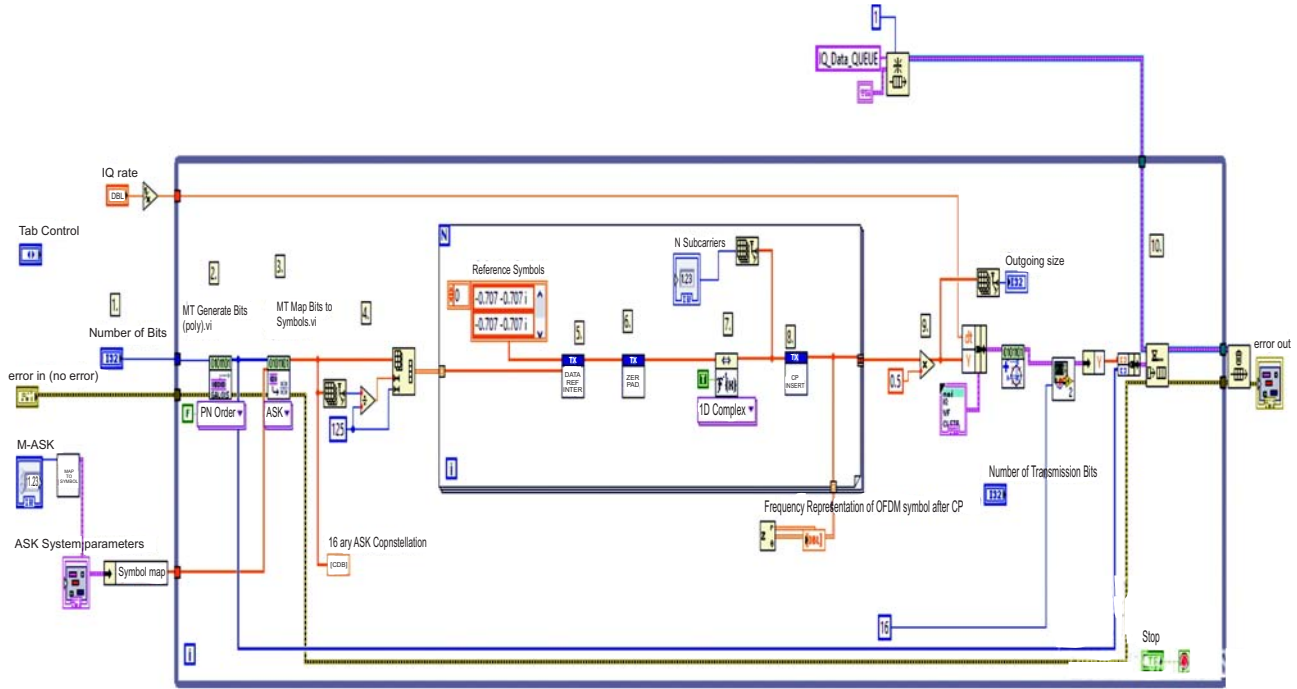

Figure 4: ASK OFDM Transmitter in LabVIEW

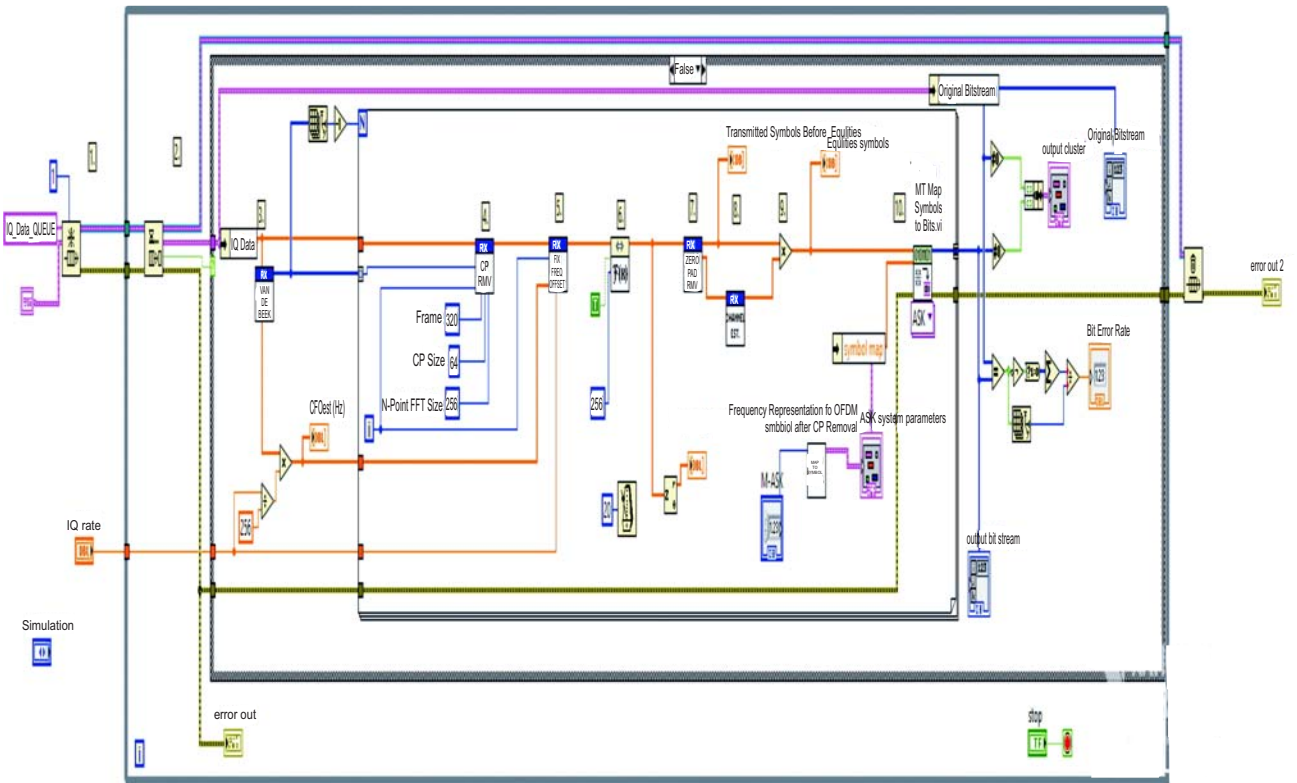

Figure 5: ASK based OFDM Receiver in LabVIEW

Procedure for Simulation of ASK based OFDM Receiver:

1. Initialize QUEUE
2. Dequeue IQ data
3. Remove the cyclic prefix
4. Compute the FFT convert in the time domain OFDM symbol to the frequency domain
5. Separate reference bits, and remove zero padding
6. Convert data symbol mapping back to data bits.

ASK based OFDM implementation using LabVIEW software platform is shown in Fig 4 and Fig.5 respectively. PN sequence helps for bit transmission which helps in analyzing BER performance at receiver side. The ASK OFDM modulator gives pulse shape using a pulse shaping filter to ease the sampling time recover process at the receiver.

Considering the transmitter side the source generates sequence of ' m ' information bits within OFDM period. These bits are being mapped to ' k ' symbols written in form of column vector using M-ASK scheme. Further channel combines the transmitted samples with impulse response, the zero mean complex AWGN & channel frequency response is added and then calculated using FFT.

Overall Circuit Description : In this project the photodiode is used for sensing the result from the ASK modulation and fed to LM-358 IC which is assembled in modules and output of IC is fed to MAX 232 pulse to bit converter and fed to LED transmitter which is covered in black round module pack in which LDR sensor is fitted at distance of 25cm away from LED and made pack for light operating sensing system. This LDR is negatively fed which gives negative pulse to micro-controller port 1 pin 2,3,4,5,6,7,8 and 9 is the reset pin for micro-controller.

10,11,12 and 13 is fed with input of LDR's output. When the module receives result from ASK modulation it tends to operate by converting process to an LED. LED when glows resistance value of LDR becomes very low and negative current passes to the micro-controller. Output of micro-controller is extracted from pin 21-30 and 32 and 33 is also output. Pin 18 and 19 is crystal oscillator operation and feeds the heart beat pulse to IC and IC works according to external program fed in HEX language to micro-controller.

According to external program the output is been extracted and this output is fed to LED's which shows the result of ASK modulation through light transferring method through LED. Power supply which is used to operate system is 5 V and 12 V regulated power supply with transformer based step down method and by converting AC step down into DC with help of IN 4007X4 diodes assembled in bridge for and capacitor 1000Mf, 25 V is added for filtration and boost up and ripple filter. This process continued up till working of the instrument. 7805 and 7812 fix regulators are connected for extracting regulated power supply and output of regulated power supply is fed to circuits

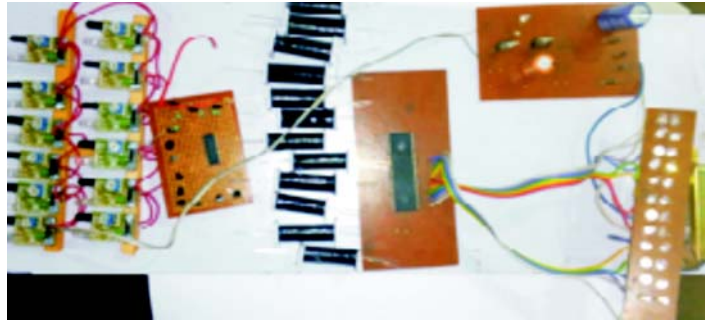

Figure 6

4. SIMULATION RESULTS

To analyze the performance of ASK based OFDM transceiver, the following simulation parameters are considered as shown in table 1. The estimated result with simulated output is obtained both for 16 ASK transmitter and receiver.

With 10000 transmitted bits and 256 subcarriers with 16 samples per symbol the ASK constellation diagram along with frequency representation for OFDM symbol after cyclic prefix is obtained for transmitter.

With IQ rate of 10M, Bit error rate 0.148 is obtained and we get the output for frequency representation for OFDM symbol after cyclic prefix removal, transmitted symbol before equalization and equalized symbols.

Simulation of 16-ASK OFDM Transmitter

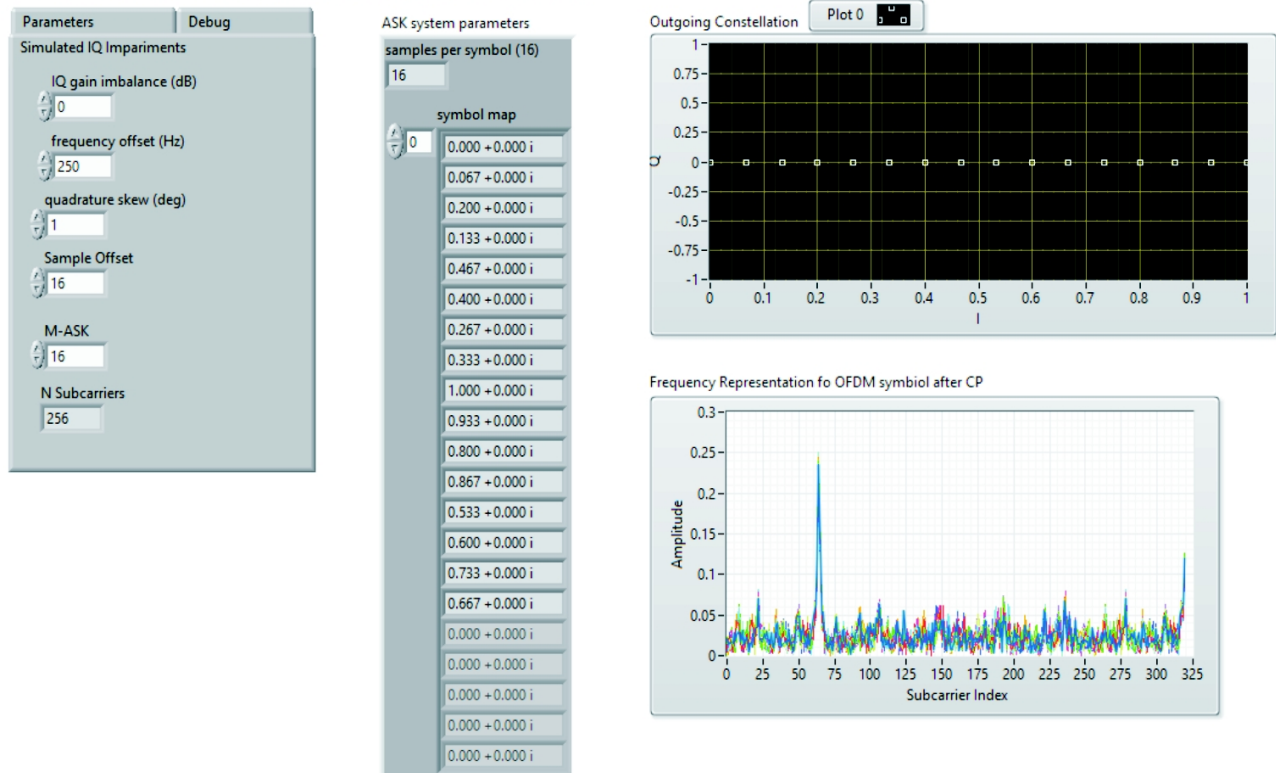

Figure 7: Simulation of 16- ASK OFDM Transmitter
 (a) Constellation diagram for 16-ASK (b) Modulated signal waveform

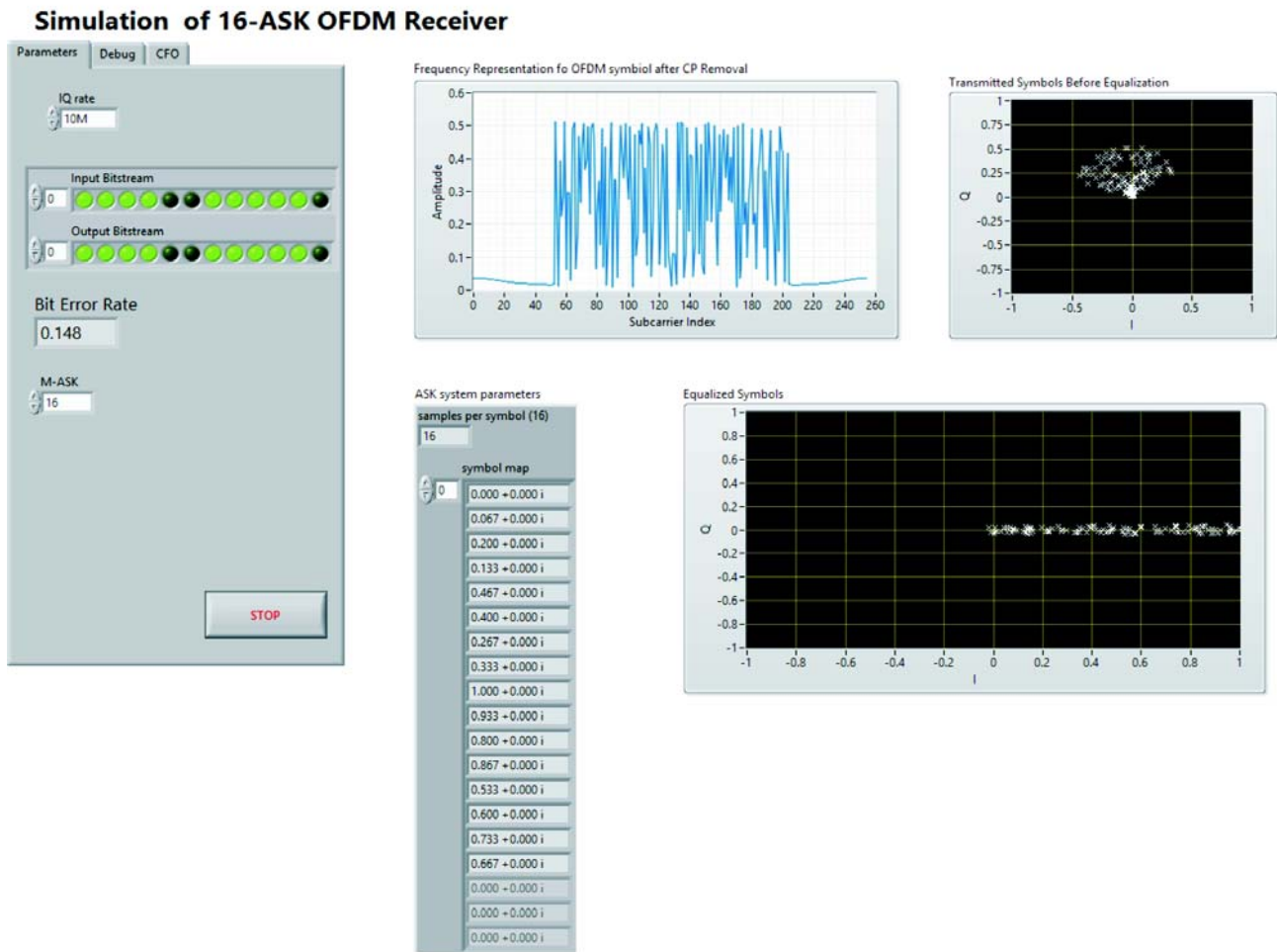

Figure 8: Simulation of 16-ASK based OFDM Receiver

5. CONCLUSION AND FUTURE WORK

In this, we have probed the ASK based OFDM for VLC system. We have simulated the 16-ASK transmitter to obtain the desired modulated waveform and at the receiver output we achieved the plot of magnitude, phase and FFT response and concluded with BER performance traits. This will help in enhancing and increasing the data transmission rate. The work is further broadened by associating this OFDM with MAX232 IC and microcontroller which will pass through digital to analog converter, the transmission will be made through LED, the receiver will have LDR and finally the communication will be accomplished via LED. With this hardware implementation one can prove that ASK modulation process is mainly used Telecommunication purpose for conveying the vocal convention can be transmitted through lighting process and which can be conveyed to optical cable distributary system. With this project of ASK modulation one has proved that the modulation of transmitting data speed can be increased ten times of transmitting frequency by light communication.

REFERENCES

- [1] Haas, Harald, "Wireless data from every light bulb". *TED Global* Edinburgh, Scotland. July 2011.
- [2] BROADCOM Corporation. 802.11n: Next-Generation Wireless LAN Technology. White paper. [Online]. Available: <http://www.broadcom.com/docs/WLAN/802-11n-WP100-R.pdf>.

- [3] W. Hussain, H. F. Ugurdag and M. Uysal, "Software defined VLC system: Implementation and performance evaluation," *Optical Wireless Communications (IWOW), 2015 4th International Workshop on*, Istanbul, 2015, pp. 117-121.
- [4] D. F. Zhang, Y. J. Zhu and Y. Y. Zhang, "Multi-LED Phase-Shifted OOK Modulation Based Visible Light Communication Systems," in *IEEE Photonics Technology Letters*, vol. 25, no. 23, pp. 2251-2254, Dec.1, 2013.
- [5] H. Elgala, R. Mesleh, H. Haas and B. Pricope, "OFDM Visible Light Wireless Communication Based on White LEDs," 2007 IEEE 65th Vehicular Technology Conference - VTC2007-Spring, Dublin, 2007, pp. 2185-2189.
- [6] Ghosh, R. Ratasuk, B. Mondal, N. Mangalvedhe, and T. Thomas, "LTE-advanced: Next-generation wireless broadband technology," *IEEE Wireless Commun.*, vol. 17, no. 3, pp. 10–22, Jun. 2010.
- [7] M. Agiwal, A. Roy and N. Saxena, "Next Generation 5G Wireless Networks: A Comprehensive Survey," in *IEEE Communications Surveys & Tutorials*, vol. 18, no. 3, pp. 1617-1655, third quarter 2016. doi: 10.1109/COMST.2016.2532458.
- [8] A.Saleem, A. A. Ikram, B. J. Bazuin, S. I. Shah and Z. Saleem, "Design and Implementation of a Software Radio based WiMAX Communication System using LabVIEW," *Networking and Communications Conference, 2008. INCC 2008. IEEE International, Lahore, 2008*, pp. 39-43.
- [9] M. Sandell, F. Tosato and A. Ismail, "Efficient Demodulation of General APSK Constellations," in *IEEE Signal Processing Letters*, vol. 23, no. 6, pp. 868-872, June 2016. doi: 10.1109/LSP.2016.256024.