



## International Journal of Control Theory and Applications

ISSN : 0974-5572

© International Science Press

Special Issue, 2016

### Power Quality Improvement in Battery Integrated Wind Energy

<sup>1</sup>N. Vani Annapurna Bhavani and <sup>2</sup>I. Swetha Mounica

Assist. Prof. Electrical and Electronics Departement S. R. K. R. Engineering College, Bhimavaram, A.P, India  
E-mail: <sup>1</sup>nvabhavani10@gmail.com; <sup>2</sup>swethamounica@gmail.com

**Abstract:** Objective: Regulation of load voltage and frequency in standalone wind energy system under fluctuating wind speeds as well as changing load conditions. Methods/analysis: This paper presents vector control strategy for load side inverter in coordination with battery energy storage system for maintaining power balance, voltage and frequency regulation in battery integrated wind-energy system under various operating conditions. Findings: The resilience of the suggested control scheme to improve the dynamic performance of standalone PMSG under transient operating conditions is validated using MATLAB/SIMULINK environment.

**Keywords:** Wind-energy system (WES), permanent-magnet synchronous generator (PMSG), battery energy storage system (BESS).

#### 1. INTRODUCTION

Renewable-energy sources utilization for the production of electrical energy has become necessary to reduce the green-house gas release into the environment and undesirable changes in the climate. Globally, Number of countries engaged in installation of renewable-energy based new power-stations. Wind energy is most important renewable-energy resource and which is fast growing technology. Wind energy based power system operation is challenging under fluctuating nature of wind speeds and variable load conditions, particularly when the operation mode of the hybrid wind power system is stand alone. The changing wind speeds cause fluctuations in wind-turbine generator, which leads to fluctuations in load voltage as well as frequency in the battery integrated wind-energy system (WES) [1]. Pitch-control mechanism is applied to the wind-turbine for the safety operation of the WES under high wind-speeds [2]. Variable speed wind-turbine systems are more advantageous when compared with the fixed speed wind-turbine systems. They generate maximum amount of power and gives less mechanical stress, higher power quality and efficiency than fixed speed wind-turbine systems.

In this type of variable-speed systems power-electronic devices have more importance, which are used to change the generator side AC voltage with varying frequency as well as amplitude to DC voltage with constant magnitude at the DC link. For the utilization of electricity at the load side DC-link voltage is transformed into AC voltage with fixed amplitude as well as frequency. Permanent-magnet synchronous generators(PMSG) are utilized to improve the reliability of the hybrid power systems with variable speed wind-energy generation

systems. Different kinds of generators are utilized in wind-energy systems, in that Permanent-magnet synchronous generators (PMSG) have more advantages when compared with the other generators.

They have simple structure, low speed operation ability and operation with high efficiency and power factor (p.f) because of its self excitation capability. When PMSG operated at low wind speeds, it does not require any gearbox system. When the presence of gearbox in the wind-energy system, which makes system unreliable because of its maintenance requirements regularly.

Stand alone wind-energy power systems are required battery energy storage systems to supply the power according to the load requirements. Power generated at the wind-energy system differs according to the wind speed variations. Battery energy storage system is store the energy if the load power requirement is lower than the generated power and which supply energy as per the load requirements when generated power is lower than the needed load power due to low wind-speeds. The charging and discharging states of the battery energy storage system (BESS) controlled with the gating pulses applied to the DC-DC bidirectional buck/boost converter [3], [4]. This helps to sustain the power-balance between the generation and load side powers which increases the reliability of power. Vector control scheme has been used for the inverter control for PMSG in reported in literature. But little focus has been done on battery integrated wind energy system. This paper mainly focuses on PMSG based wind energy system with battery for maintaining the voltage and frequency and also to maintain the power balance system with the Vector control based inverter.

This paper is organized into the following sections. Section II describes about the Battery connected wind energy system configuration with PMSG modeling and different control strategies of inverter and battery energy storage system. Section III discusses about the simulation results and discussion. Finally Section IV concludes with conclusions.

## 2. BATTERY CONNECTED WIND-ENERGY SYSTEM CONFIGURATION

In this stand-alone Battery connected wind-energy system (WES), PMSG without using any gearbox is connected directly with wind-turbine system. The generated output power of the PMSG flows through the diode-bridge rectifier converted into DC voltage. Wind-speed changes according to the climatic changes due to this DC-DC buck/boost converter is employed for maximal power extraction from the available wind-power [5], [6]. Power balance in between load & generation sides is maintained with the battery-energy storage system (BESS). Vector-controlled three phase PWM inverter is used to get the AC voltage at the load side. LC filter is connected in between inverter and load to reduce the harmonic distortion on load side. The proposed system schematics-diagram is given in Fig. 1.

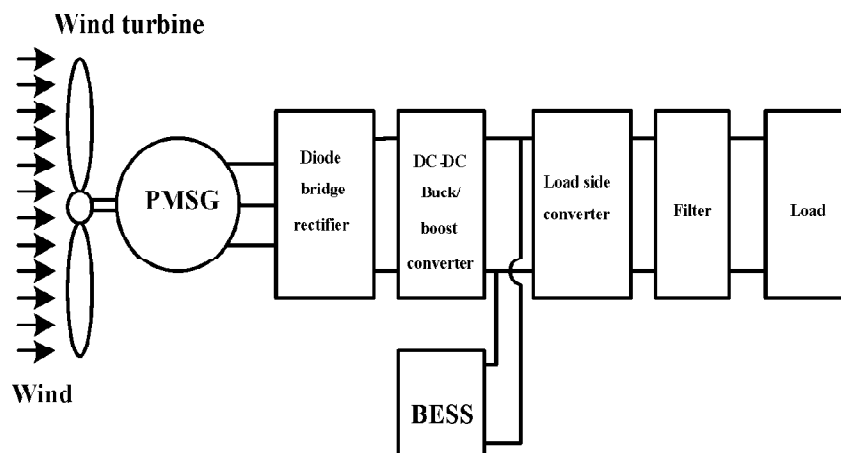

**Figure 1: Proposed battery integrated wind-energy system**

## 2.1. Wind turbine

Wind turbine converts the linear kinetic-energy into a rotational kinetic-energy [8]. Power curve is the very important technical information for a wind-turbine, which provides the relationship between wind-speed & generated power. The wind-power at any wind-speed is expressed as:

$$P_w = \left(\frac{1}{2}\right) \times (\rho \cdot A \cdot v_w^3) \quad [1]$$

Where  $P_w$  is the wind-power (watts),  $\rho$  the air density (Kg per cubic meter),  $v_w$  is the wind-speed (m/s) and  $A$  the swept area of the wind turbine blade ( $m^2$ ).  $C_p$  is the coefficient of the wind-turbine power. The wind-turbine captured mechanical power may be given by:

$$P_{mech} = (P_w) \times (C_p) \quad [2]$$

$$P_{mech} = \left(\frac{1}{2}\right) \times (\rho \cdot A \cdot v_w^3) \times (C_p) \quad [3]$$

Wind-power coefficient ( $C_p$ ) is the measure of efficiency of wind-power into the mechanical power at the generator rotor shaft.  $C_p$  is expressed in tip-speed ratio ( $\lambda$ ) & pitch-angle ( $\beta$ ) in degree [9]. If blade pitch-angle is zero then  $C_p$  can be expressed as;

$$C_p(\lambda, \beta) = \left(\frac{60.04 - 4.69 \times \lambda}{\lambda}\right) \times e^{\left(\frac{0.735 \times \lambda - 21}{\lambda}\right)} + \left(\frac{0.0068 \times \lambda}{1 - 0.035 \times \lambda}\right) \quad [4]$$

$$TSR(\lambda) = \frac{\omega_r \times R}{v_w} \quad [5]$$

Wherein  $\omega_r$  represents the rotational-speed of the shaft (rad/s) while  $R$  represents the radius of wind-turbine blade (m).

## 2.2. Permanent-magnet synchronous generator (PMSG)

PMSG have high efficiency and energy-field than the electrically excited machines. Field-winding is absent in PMSGs due to this, there is no requirement of any additional-power for the magnetic-field excitation. The dynamic-model representation of the PMSG in rotating or synchronous (dq) reference-frame as:

$$V_{ds} = -R_s \cdot i_{ds} - L_d \left(\frac{di_{ds}}{dt}\right) + L_q i_{qs} \omega \quad [6]$$

$$V_{qs} = -R_s \cdot i_{qs} - L_q \left(\frac{di_{qs}}{dt}\right) - L_d i_{ds} \omega + \phi_m \omega \quad [7]$$

Wherein  $V_{ds}$ ,  $V_{qs}$  &  $i_{ds}$ ,  $i_{qs}$  are d-axes and q-axes voltages currents of the PMSG.  $R_s$  and  $\omega$  are stator-resistance and electrical angular-frequency correspondingly.  $L_d$  and  $L_q$  are inductances of direct and quadrature axis respectively.  $\phi_m$  is the flux-linkage established by the permanent-magnet. Electromagnetic torque expression for the PMSG is given as

$$T_e = \left(\frac{3}{2}\right)(p)\left((L_d - L_q) \times (i_{qs} i_{ds}) - \phi_m i_{qs}\right) \quad [8]$$

Where  $p$  represents number of pole pairs.  $L_d$  and  $L_q$  are equal when the PMSG s rotor construction is cylindrical, then the torque equation is as follows

$$T_e = -\left(\frac{3}{2}\right)(p)(\phi_m i_{qs}) \quad [9]$$

### 2.3. DC\_DC Buck/Boost converter with MPPT

The unidirectional buck/boost converter is act as an interface between the BESS and diode rectifier. Simplified circuit model of the buck/boost converter is shown in Fig. 2. The relation between primary/secondary or input/output voltages and currents is given as:

$$V_b = (V_{dc})\left(\frac{1}{1-D}\right) \quad [10]$$

$$I_b = (1-D) \cdot I_{Lconv} \quad [11]$$

Wherein,  $D$  represents the duty-cycle. If,  $V_{dc} \geq V_b$  the buck/boost unidirectional converter is not functioning and the current given by the generator flows via the bypass Schottky-diode ( $D_s$ ).

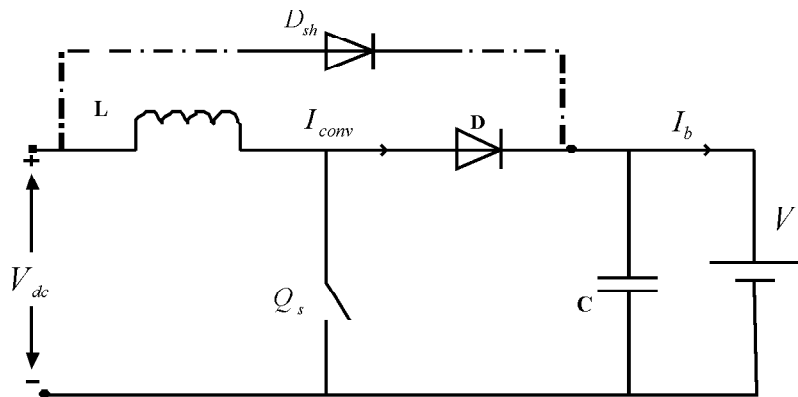

Figure 2(a): Schematic diagram of the boost converter

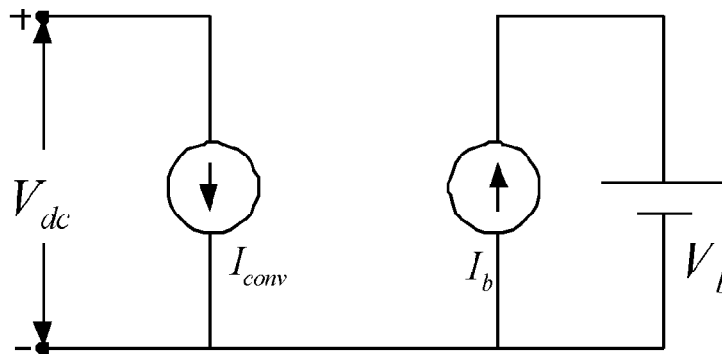

Figure 2(b): Equivalent-circuit model of the boost converter

The reference converter-current ( $I_{Lconv}^*$ ) is given by maximum-power point tracking (MPPT). The fault signal of the reference converter-current as well as the computed converter-current ( $I_{Lconv}$ ) is given to the PI-controller. The output signal of the PI-controller is totaled with the positive voltage-reaction, that given as  $1 - V_{dc}/V_b$ . Switching signal ( $S_T$ ) is generated by the PWM-generator with the help of duty-cycle. Control strategy for the buck/boost converter is given by Figure 3.

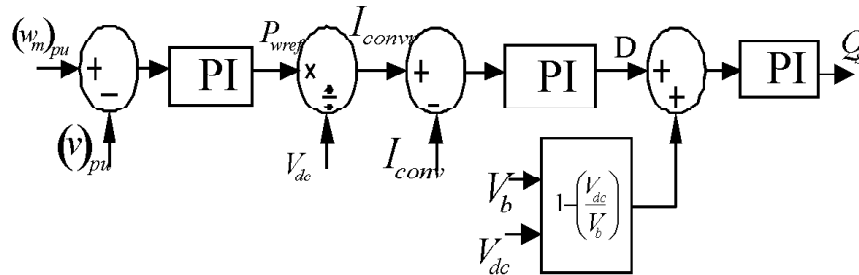

Figure 3: Buck/boost converter control scheme with MPPT

For generating the maximal power from the wind-energy system maximal-power point tracking (MPPT) control is utilized in this HWES. The control scheme for MPPT is shown in Fig. 3. Wind-speed ( $v_{p.u.}$ ) and wind-turbine generator speeds ( $n_{p.u.}$ ) are used to generate reference wind-power with the help of PI controller.

#### 2.4. Battery energy storage system (BESS)

DC-DC bi-directional Buck/Boost converter is controller for battery, which functions as a buck-converter during charging condition and while acts as a boost-converter in the discharging condition. The aim of the battery-energy storage system is for supplying balanced power according to the load requirements in fluctuating wind conditions. Schematics of the battery-energy storage system given in fig. 4.

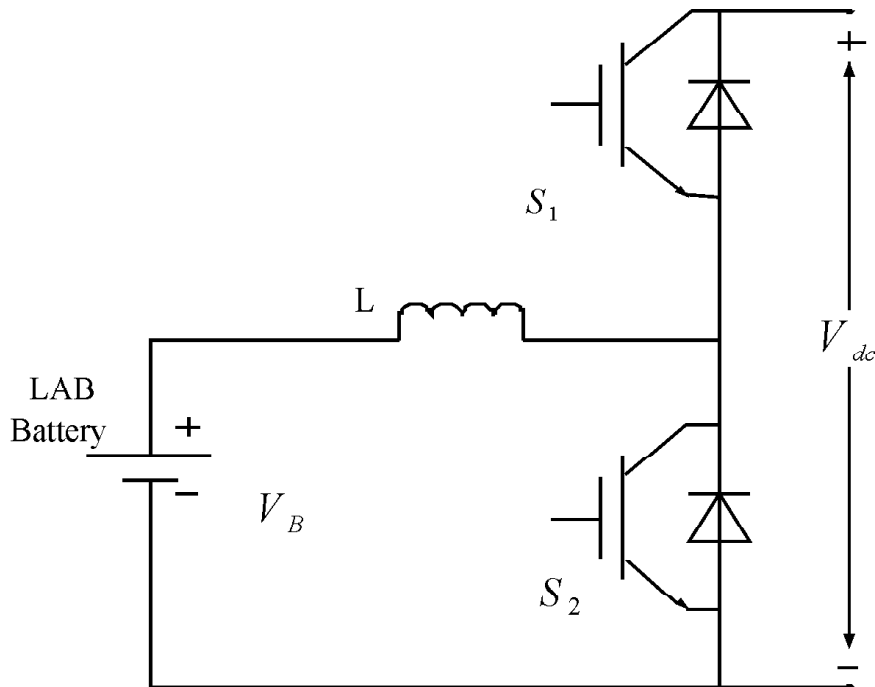

Figure 4: BESS connected to dc-link through bi-directional converter

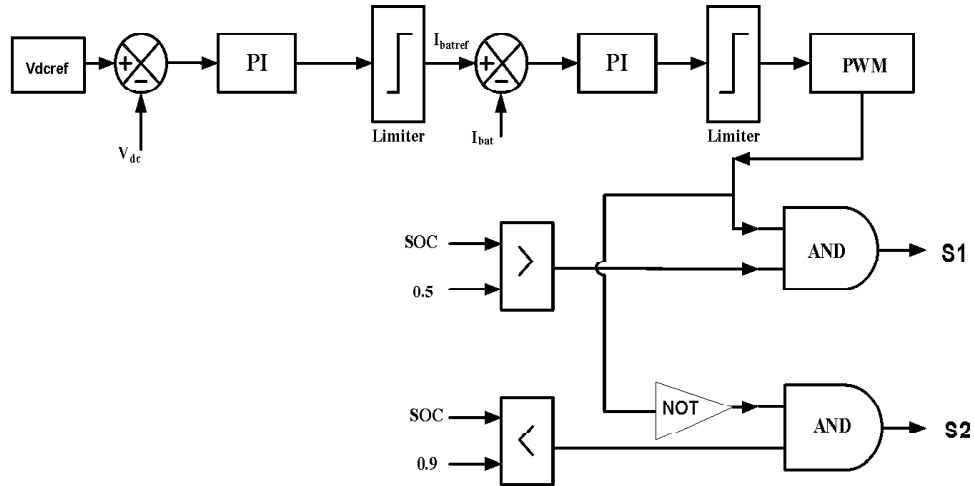

Figure 5: BESS control strategy

DC-Link voltage and state of charge (SOC) information controls the battery bi-directional buck/boost converter as given in Fig. 5. The charging and discharging condition of the battery is identified with the SOC value. In this proposed battery control scheme, if the battery SOC value is higher than the 50% then the BESS is ready to supply power to the load or which is in discharging mode. BESS is in charging mode if the SOC value is lesser than 90%.

### 2.5. Load side converter control

The primary goal of the Load-side converter/inverter is to control the magnitude of the voltage and frequency. Inverter/converter is an interface in between DC-Link and the load to convert constant DC voltage into AC voltage at load side. The control scheme applied to this load side converter is vector-control strategy on the basis of synchronously rotating reference-frame as given in Fig. 6. PI controllers are used to implement this control scheme. Implementation of the vector-control scheme for load-side converter is given in Fig. 7.

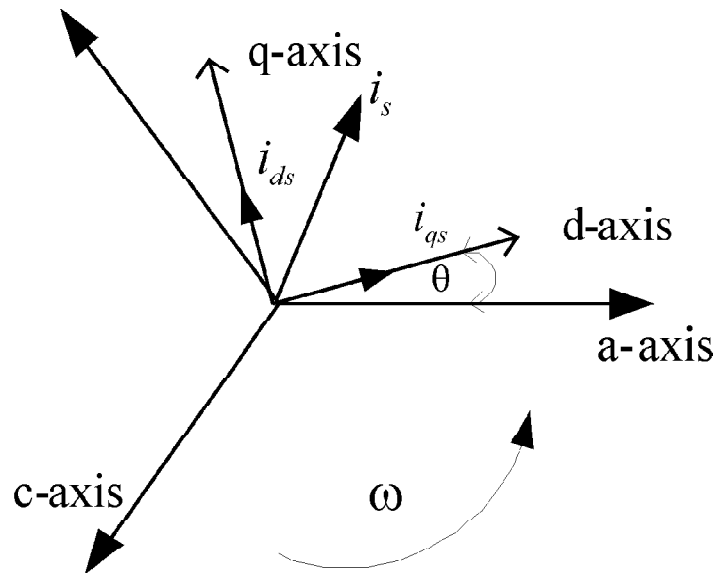

Figure 6: Stationary (abc) and synchronous (dq) reference frames

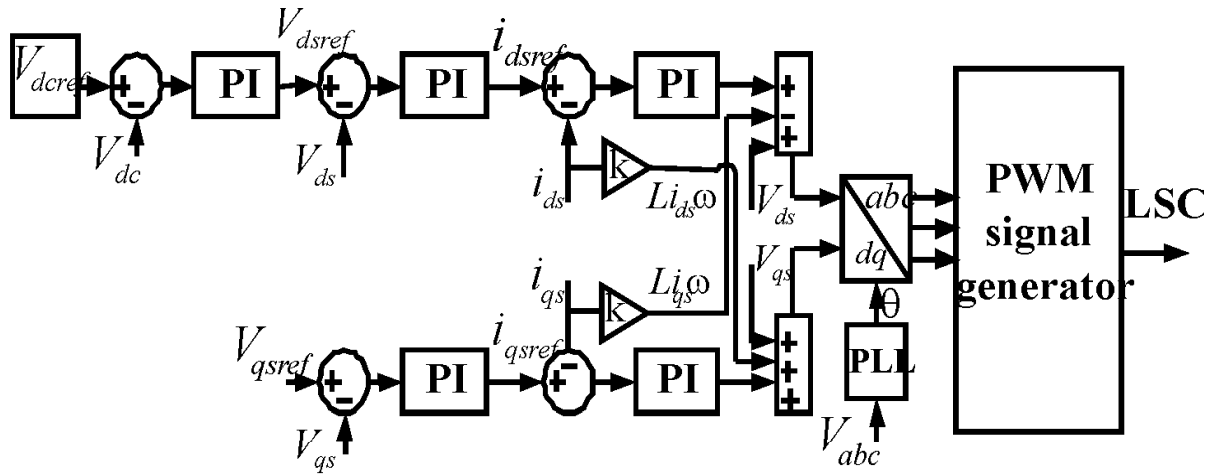

Figure 7: Vector-control strategy for load-side converter

In this vector-control scheme outer loop maintains DC-link voltage at reference value & inner loop controls the current values. The vector-representation of the stationary (abc) and synchronous (dq) reference-frames given in Figure 6. The voltage equations in synchronous reference-frame (dq) are as follows

$$V_{ds1} = V_{ds} - V_{ds1}^* + \omega L i_{qs} \tag{12}$$

$$V_{qs1} = V_{qs} - V_{qs}^* - \omega L i_{ds} \tag{13}$$

$$V_{ds}^* = R i_{ds} + L \frac{d i_{ds}}{dt} \tag{14}$$

$$V_{qs}^* = R i_{qs} + L \frac{d i_{qs}}{dt} \tag{15}$$

The active and reactive powers using rotating reference-frame (dq) are

$$P_{inverter} = V_{ds} i_{ds} \tag{16}$$

$$Q_{inverter} = V_{ds} i_{qs} \tag{17}$$

Therefore, direct-axes and quadrature-axes current components controls the active as well as reactive powers respectively.  $V_{ds}$  and  $V_{qs}$  are d-axis & q-axis voltage components as well as  $i_{ds}$  and  $i_{qs}$  current components in rotating reference frame.  $V_{ds1}$  and  $V_{qs1}$  are load-side converter voltages in dq reference-frame.

### 3. SIMULATION RESULT ANALYSIS

The behaviour of the hybrid wind energy system, on the basis of PMSG is studied under differing loads as well as wind conditions. The resilience of the suggested hybrid wind energy system is given with regard to the voltage as well as frequency regulations. The system response of the PMSG-based power system in varying wind as well as load conditions are given in Figure 8.

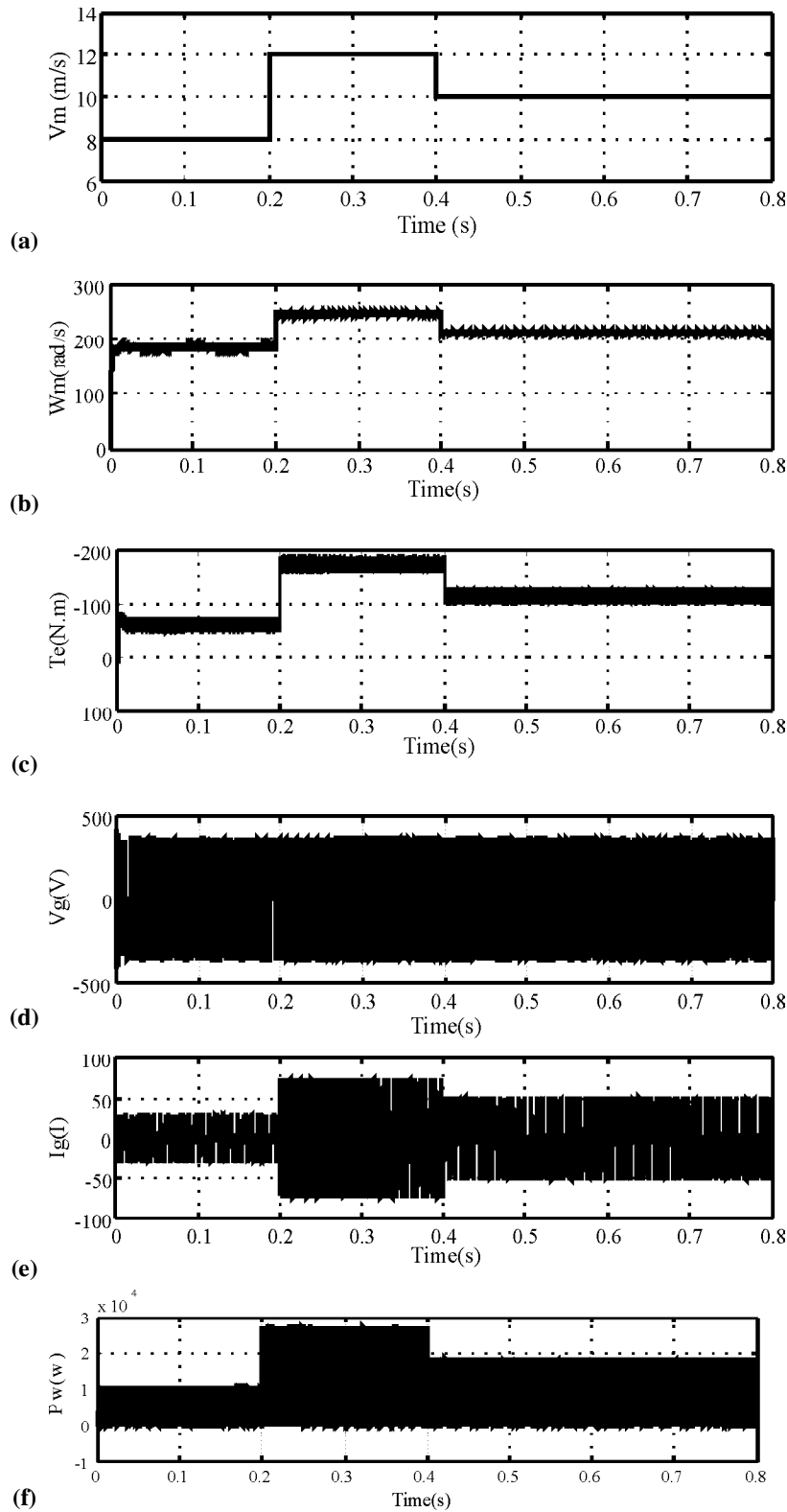

**Figure 8: Response of the PMSG-based Hybrid wind energy system in varying wind as well as load conditions: (a) wind speed, (b) Rotor speed  $W_m$  (rad/s), (c) Electromagnetic Torque  $T_e$  (N.m), (d) Generator voltage (V), (e) generator current (I) and (f) generator power**



The wind profile in system simulation is given in Fig. 8(a). It is noted that the wind velocity is initialized originally at 8 m/s. At  $t = 2$ s, the wind velocity increases to 12 m/s, then it is decreases to 10 m/s at  $t = 0.4$ s. During increase and decrease in wind speeds the rotor speed, PMSG Power and electromagnetic torque also increased and decrease in response to the changes in wind velocity conditions as shown in Figure 8(b), (c). The PMSG generates the extra power during increase in wind velocity and supplies to load. The variation of the wind power as per the variations of the wind velocity is given in Fig. 8 (f).

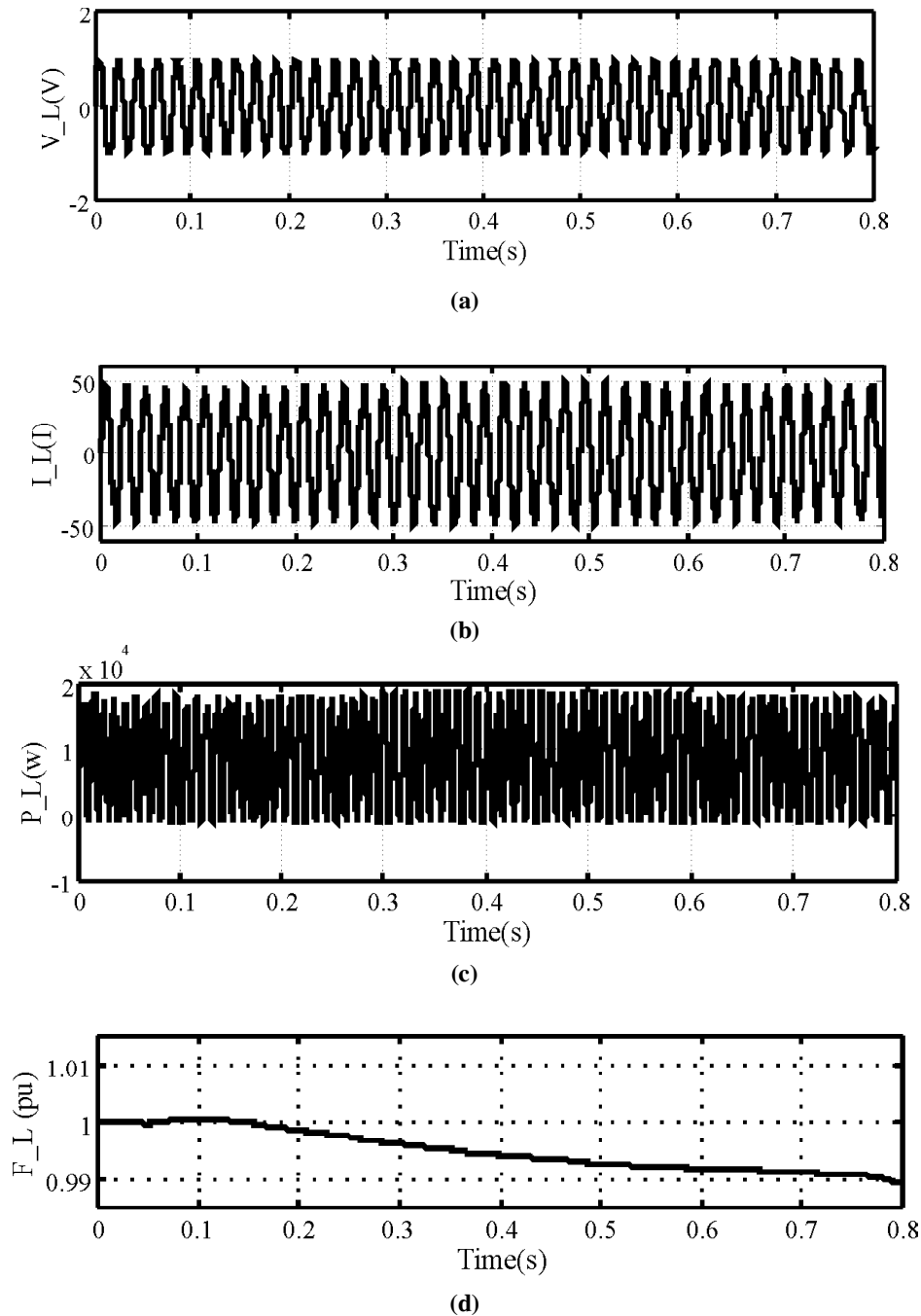

**Figure 9: Response of the PMSG-based Hybrid wind energy system in varying wind as well as load conditions:, (a) Load voltage (pu), (b) Load current, (c) Load power (w) and (d) Load side frequency (pu)**

Fig. 9(a) gives the DC-link voltage of the rectifier/inverter system. With the control strategy for battery storage, the DC-link voltage is sustained near the rated value. The simulated behaviour of the load voltage at load side is given in Fig. 9(b). It is noted that the voltage of the system is unaffected by the wind speed changes that occur at  $t = 2$  s &  $t = 4$  s but a voltage dip at  $t = 3$  that relates to the load step up as given by Figure 9(d). A instantaneous voltage rise happens at  $t = 6$  s that relates to the load step down. The load voltage is sustained within  $\pm 0.5\%$  in normal operations. Fig. 9(c) represents the load current of the hybrid wind energy system with step up load 2kw at  $t=3$ s and step down load 3kw at  $t=6$ s. The behaviour of the operating frequency of the hybrid wind energy system is given in figure 9(e). It is noted that the frequency is within  $1 \pm 5 \times 10^{-3}$ pu in the whole operation with no regard to wind or load change. But, the greatest frequency deviation is corresponding to load deviation. Moreover, it is seen that wind speed change does not impact operating frequency as seen in Figure9(e).

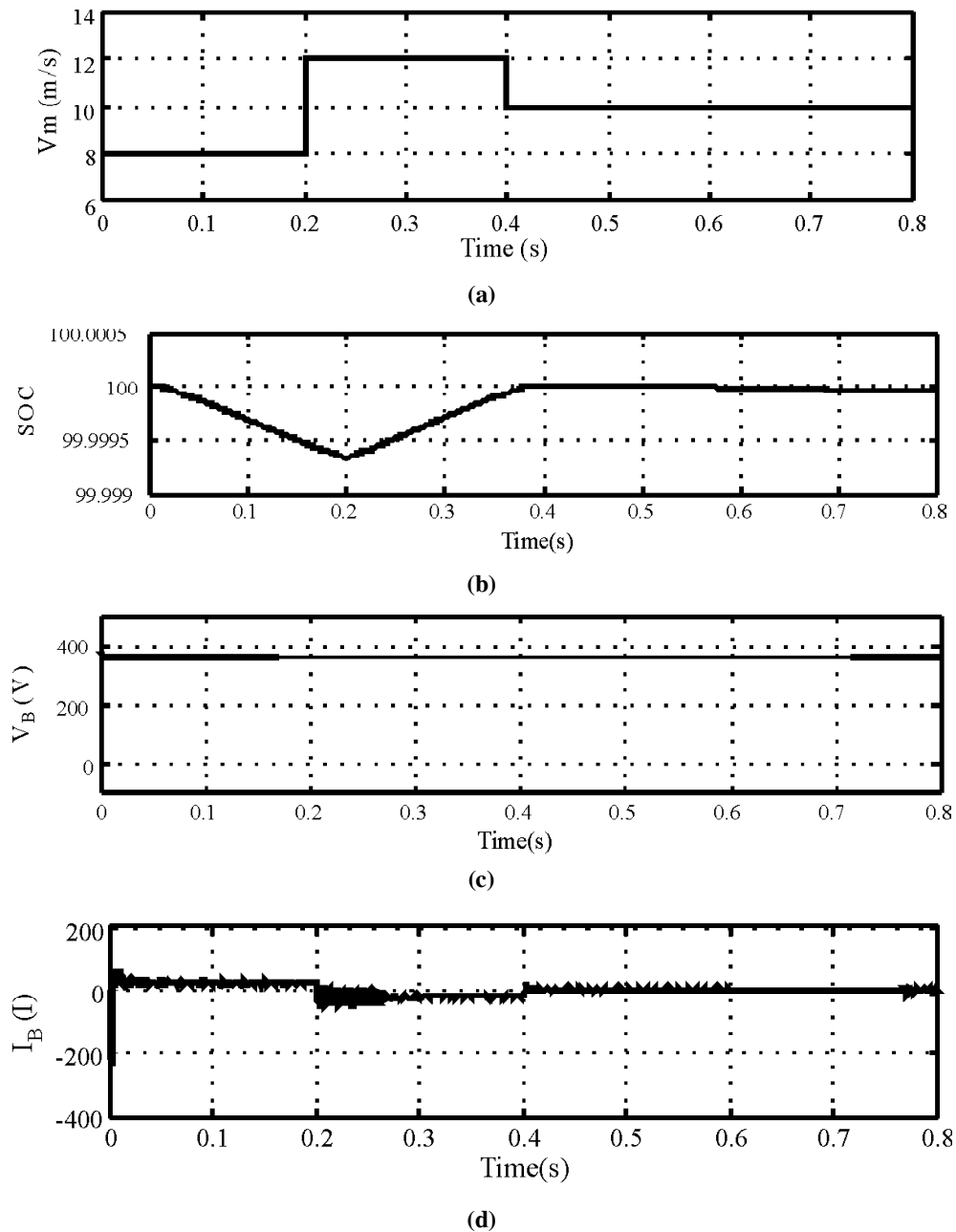

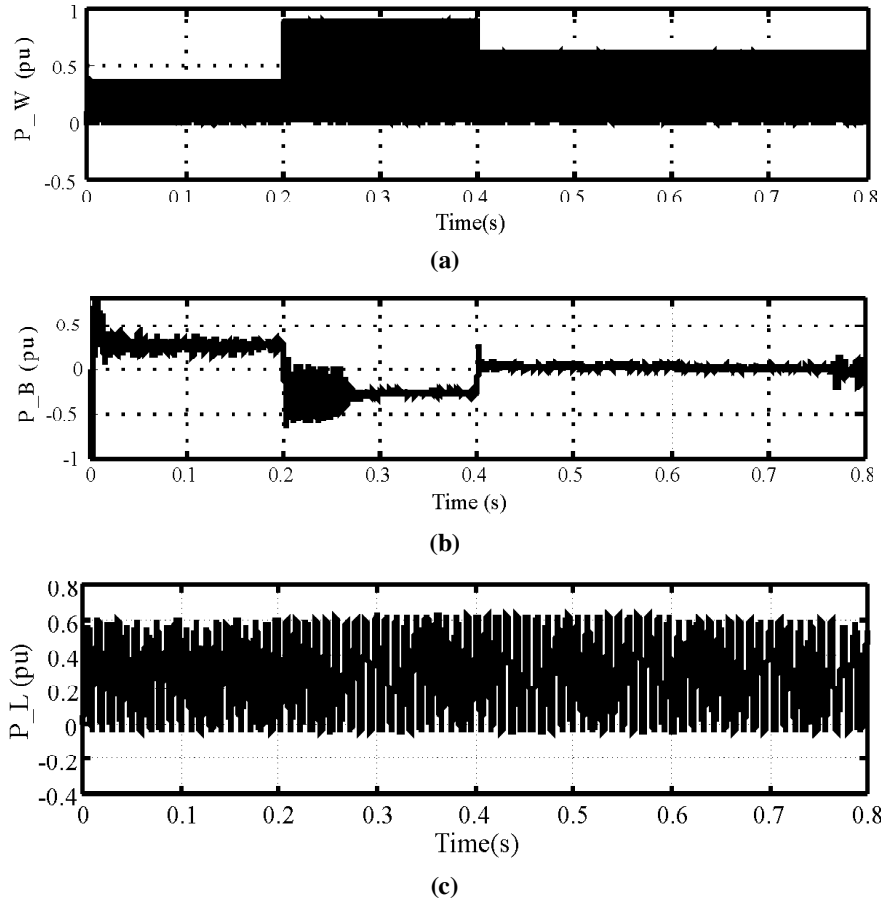

FFT analysis of the PMSG-based Hybrid wind energy system in various wind & load conditions when load side converter control scheme is implemented with PI controller is shown in below fig. 11.

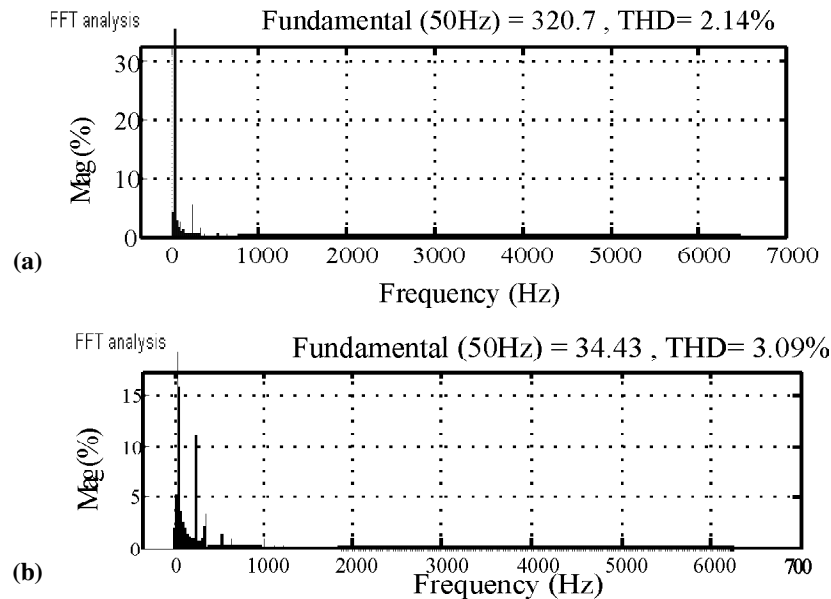

Figure 11: FFT analysis of the PMSG-based Hybrid wind energy system in varying wind as well as load conditions: (a) Load voltage, (b) Load current

Total harmonic distortion (THD) of the load side voltage as well as current are given in fig. 11(a) & (b) respectively. This FFT analysis has been carried out at fundamental frequency 50Hz. The fundamental harmonic component of the voltage is 403.4 and the THD values of the voltage and current at the load side 2.14% and 3.09% correspondingly.

#### **4. CONCLUSION**

The study examined the dynamic performance of standalone battery integrated direct drive PMSG using Hybrid proportional controller with vector control based PI controllers in the outer and inner loops of load side converter. The robustness of the proposed controller to improve the dynamic performance of direct drive PMSG is demonstrated under various operating conditions such as variable wind and loads.

From the simulation results it is seen that the load parameters such as load voltage, frequency and machine side parameters such as stator voltage, current, torque oscillations and dc link voltage are well regulated within the acceptable limits with the proposed control scheme.

#### **REFERENCES**

- [1] NishadMendis, Student Member, IEEE, Kashem M. Muttaqi, Senior Member, IEEE, Saad Sayeef, Member, IEEE, and SarathPerera, Member, IEEE, "Standalone operation of wind turbine based variable speed generator with maximum power extraction capacity", IEEE Transactions on energy conversion, vol. 27, no. 4, December 2012.
- [2] AradhyaSambhuSatpathy, N. K. Kishore,Senior Member, IEEE, DepaprasadKastha, Member, IEEE, and N.C. Sahoo, Member, IEEE, "Control Scheme for a Stand-Alone Wind Energy Conversion System", IEEE Transactions on Energy Conversion, Vol.29, NO. 2, JUNE 2014.
- [3] Haruni A. M. O., Gargoom A., Haque M. E., and Negnevitsky M.: Dynamic Operation and Control of aHybrid Wind-Diesel Stand Alone Power Systems. In: IEEE conference on Centre of Renewable Energy and Power Systems (CREPS), 2010.
- [4] Barton J K and Infield D G, 'Energy storage and its use with intermittent renewable energy', IEEE Transaction on EC, Vol. 19, No.2, June 2004, Pages 441-448.
- [5] LuminitaBarote, CorneliuMarinescu and Marcian N. cirsteea, " Control structure for single phase stand alone wind based energy sources", IEEE Transactions on Industrial Electronics, Vol.60, No.2, February 2013.
- [6] Mutoh N and Nagasawa A, 'A maximum power point tracking control method suitable for compact wind power generators', Proceeding of the IEEE Power Electronics Specialists Conference (PESE), 18-22 June, 2006,Pages 1-7.
- [7] Tin ZarKhaing, LwinZaKyin, "Control Analysis of Stand-Alone Wind Power Supply System with Three Phase PWM Voltage Source Inverter and Boost Converter", International Journal of Electrical and Computer Engineering(IJECE), Vol.5,No.4, august 2015, pp.798-809.
- [8] Chinchila M. Arnaltes S and Burgos J C, 'Control of permanent-magnet generators applied to variable-speed wind-energy systems connected to the grid', IEEE Transactions on EC, Vol. 21, Issue 1, March 2006, Pages 130-135.
- [9] Mukhtiar Singh, Ambrish Chandra, "Control of PMSG based variable speed-wind battery hybrid system in a isolated network", IEEE Trans. Power Delivary, Vol.3, pp549-557, Apr.2009.
- [10] Datta R and Ranganathan VT, 'A method of tracking peak power points for a variable speed wind energy conversion system', IEEE Transactions on EC, Vol. 18, No. 1, March 2003, Pages 163-168.