

INTERNATIONAL JOURNAL OF ELECTRONICS ENGINEERING

ISSN : 0973-7383

Volume 11 • Number 1 • 2019

Wireless Power Transmission: A Simulation Study

M. Likhith^a, P. Naveen Kumar Reddy^b, S. Jagadeeswara Rao^c, V. Nirmith Sudev^d and Mamatha I^e

^{a-d}Dept of Electrical and Electronics Engineering, Amrita School of Engineering, Bengaluru, Amrita Vishwa Vidyapeetham, Amrita University, India. ^bnaveenkumarreddy94@gmail.com; ^emamraj78@gmail.com

Abstract: In this work, design and closed loop simulation of a Wireless power transfer (WPT) system is carried out. WPT technology is one of the fastest growing technologies due to its emerging applications. Researches in this technology mainly focus on improving the efficiency of inductive link section. This work is concerned with the design of coils driving converters and the power conditioning at the receiver side of the system. Design and simulation of WPT system is carried out to supply a load of 90W at 20V, 4.5A such as an adapter for notebook computers. Both transmitter and receiver coils are designed to operate at a resonance frequency of 50kHz. In a WPT system, voltage induced at the receiver coil depends on the mutual coupling which in turn depend on distance between the two coils and the coil inductances. It is observed that the resonance coupling improves the efficiency of transmission allowing one to transmit at lesser frequency (in kHz range instead of MHz range). To mitigate the voltage variations at the receiver side, a closed loop system is designed using PI controller. It is observed that the output of the system is maintained at 19V, 4.3A while varying the coupling coefficient from 0.3-0.5. A closed loop WPT system is designed and simulated which can be implemented on hardware in future.

Keywords: Wireless Power Transfer, Inductive coupling, Resonant coupling.

1. INTRODUCTION

Wireless Power Transfer (WPT) was first demonstrated by Nikola Tesla in 1890's. By the decade from its invention, it has evolved as promising field and has found its own importance because of its various advantages. Elimination of a power cord and the task of battery replacements make WPT enabled devices more convenient and reliable. Its convenience level of transferring energy and less maintenance techniques promoted more researches in this field and made it to have its own importance in both the consumer electronics market and higher rated applications. Where ever there is a need of continuous power supply and is not feasible to use wired connection, wireless transmission is useful. Applications of WPT technology include biological implants, oil platforms to name a few.

There are three techniques of wireless power transfer namely, radiative, inductive and resonant coupling. In radiative transfer maximum energy is wasted and suitable for small amount of power to be transmitted (milliwatts).

For long distances, directive radiative transfer using highly directional antennas is efficient and has harmful influences on human body. On the other hand, inductive coupling using resonance technique is more efficient for short distance (just in several centimeters). As the objects exchange energy efficiently under resonance, coupled magnetic resonances will make possible the commercialization of a midrange wireless power transfer. The high degree of scalability of power level and distance range in solutions based on highly resonant wireless power transfer enables a very diverse array of configurations.

As wireless power transmission is a most promising field, there were many researches that have been published on this technology. Kurs et.al[1] used the concept of self resonance of strongly coupled coils and experimentally proved the efficient non-radiative power transfer at a distance of 8 times the coil radius. Further a quantitative model is developed to validate the experimental results for power transfer which is accurate to 95%. Similar technique of non radiative power transfer is used by Zue et.al[2] where authors tried to relate the effect of back electromotive force in receiver coil with the varied distance between the transceiver coils. Wireless power transmission of upto 50W over a distance of 1m at 60% efficiency was reported. Shoki in[3] addressed the problems related to commercialization of WPT technologies and initiatives of WPT-WG systems in Japan. Sibakoti and Hambleton [4] showed a system where AC oscillating waveform is transferred wirelessly into a DC voltage on the receiving end with high frequency which could be used to power an electrical load (in watts) to demonstrate instantaneous power transfer. A simple circuit model is derived showing the essential features of resonant coupling implications on the various parameters.

A model from physical theory, antenna theory and circuit theory for resonant inductive coupling is derived by Balust et.al[5] to predict the behaviors of the RIC systems under various conditions. It has been proven that the circuit theory model gives better accuracy for transition period conditions. Further, the parameter selection such as input frequency, resonant frequency, distance between coils and source and load resistances for maximum power transfer has been reported by the authors. Hasan et.al [6] showed the simulations for wireless power transmission using MultiSim software. Authors reported that the system designed is immune to shielding materials such as plastic, books and the power can be transmitted wirelessly for low voltage chargers. A method of frequency tracking to mitigate the drop in efficiency of wireless power transfer is proposed by Yan et.al[7]. Circuit model of WPT system and the theory of mutual inductance is discussed. Also, the reason for drop in efficiency such as distance and orientation of coils, deviation of center point are referred and technique of adoptive resonance frequency has improved the efficiency.

Duarte and Felic[8] showed the measurement techniques for coupling co-efficient and mutual inductance in order to improve efficiency from transmitter to receiver coil. Coupling capacitors are placed on both the coils in order to improve the transmission efficiency. Main advantage of resonant coupling is the usage of low-cost semiconductor devices operating at kHz range for converter circuits. This frequency range switching helps to reduce the radiation and conduction losses. Ria et.al[9] have proposed a system using single stage converters against the conventional method of rectifying and using dc-dc converter in order to improve the overall efficiency of the WPT system. Rohith et. al. [10] have implemented a open loop system to charge a cell phone device at 5V, 0.5A wirelessly using solar power while keeping the distance of transmission as 5-8cm. The frequency of transmission was 241kHz. The factors like line and load regulations are not been addressed as the system is open loop. The objective of this work is to transmit power wirelessly to charge loads like laptop, using inductive resonance principle. As the voltage at receiver end varies with the distance between the coils, a closed loop circuit using PI controller at the receiver side is used. Closed loop simulation of the proposed work is carried out to supply a load of 90W at 20V, 4.5A which can be used to charge a laptop.

Rest of the paper is organized as under: section 2 describes the block diagram and the design aspects of the proposed WPT system. Simulation results and analysis is carried out in section 3. Section 4 concludes the work and briefs about the scope for future work.

2. BLOCK DIAGRAM AND DESIGN

This section describes the block diagram and design of the proposed system.

A. Block Diagram

The Figure 1 shows the block diagram of the work proposed. The input is taken from the ac main and converted to dc using rectifier circuit. The output of the rectifier is converted to required frequency ac with the help of inverter circuit switched at high frequency which is chosen to resonate the transmitter and receiver coils. High frequency ac is given to transmitter coil which transmits the power wirelessly. Voltage is received at receiver by using induction principle and is converted to load power rating by using rectifier and dc-dc converter (Chopper). A Proportional-Integral (PI) controller in the feedback section at the receiver side is used to control the fluctuations of the voltage induced at receiver in order to maintain a constant output voltage to the load.

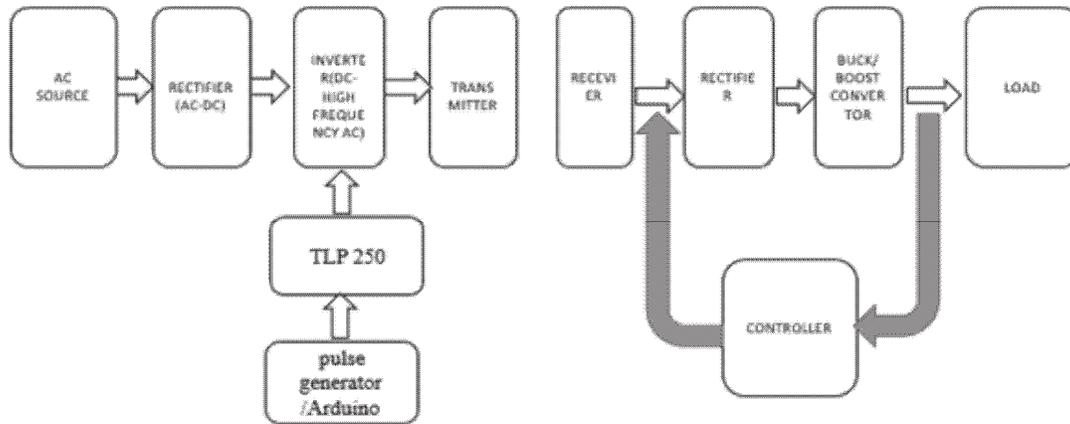

Figure 1: Block diagram of the proposed WPT system

B. Design

In this work, design and simulation of a system for wireless power transmission is carried out to power a load at 20V, 4.5A. Input of sinusoidal signal with 158V as peak voltage is fed to the circuit in order to obtain an output of 100V dc from the rectifier circuit.

1. *Rectifier*: Full wave bridge rectifier is considered in the proposed design. The rectifier is built using diodes and filter capacitor.

DC output of the rectifier circuit is given by, $V_{dc} = \frac{2V_m}{\pi} = 100 \text{ V}$ since $V_m = 158 \text{ V}$.

$$\text{Voltage ripple} = \frac{I_{dc}}{F.C} = \frac{V_{dc}}{R_L.C} \Delta t$$

Assuming 3% (9V) ripple, frequency of operation $f = 50\text{Hz}$, $F =$ frequency of ripple voltage $= 2.f$ (twice the input frequency) resulted in $\Delta t = \frac{1}{F} = 10 \text{ msec}$, $V_{dc} = 100\text{V}$, $R_L.C = 0.1111$ results in a filter capacitor of value $C = 20\mu\text{f}$.

2. *Inverter*: Output of the rectifier which is 100V is fed to an inverter. The elements of the inverter are MOSFET and pulse generation circuit. For an input 100V, inverter output is a square wave fluctuating between $\pm 100\text{V}$. Pulse generator produces switching pulses of 50kHz and are fed to the inverter switches. Hence, inverter generates square wave of $\pm 100\text{V}$ at 50kHz frequency.

3. *Transmitter Coil*: Output of the inverter is fed to the transmitter coil which is operating at 50kHz frequency. Inductance of transmitter coil is given by the Wheeler's long coil formula,

$$L = \frac{r^2 N^2}{(9r + 10.l)} \text{ (micro Henrys) for } l > 0.8r \quad (1)$$

where l = air core length in inches, r = radius of the coil in inches. Assuming $l = 9.5$ cm, thickness = 4 mm, diameter ($2r$) = 8.5cm and number of turns $N = 20$, results in the inductance value as $L = 19.79 \mu\text{H}$, and assumed capacitance as $C = 0.1 \mu\text{F}$. Here, a cylindrical winding coil made of a 4mm copper wire having high current carrying capability (4A) is used as transmitter coil. This allows the transmitter to transmit power to many loads.

4. *Receiver Coil*: Receiver coil is designed in order to receive the signal at resonant frequency. Flat spiral winding with inner diameter (D_1) = 1.15 cm, thickness (w) = 19SWG = 18 AWG = 1 mm, spacing between the coils (s) = 0.54 mm, no. of turns $N = 45$ is chosen for receiver coil.

$$L = \frac{N^2 \times A^2}{30 \times A - 11 \times D_1} \text{ and } A = \frac{D_1 + N(w + s)}{2} \text{ for low frequencies } < 30\text{MHz}. \quad (2)$$

In (2) all dimensions are in inches. The inductance is found to be approximately 94.5uH and a capacitance of 0.02uF is assumed. For the receiver coil, single layered winding is used such that maximum flux lines by the transmitter can be cut by it. The coil is made of a 1mm copper wire having high current carrying capability of about 4A.

Mutual inductance between the coils = $k\sqrt{L_1 L_2}$, Transmitter coil inductance $L_1 = 19.79 \mu\text{H}$, Receiver coil inductance $L_2 = 94.5 \mu\text{H}$, k = coupling co-efficient (varies from 0.1 to 0.5), Assuming 'k' value as 0.3, mutual inductance = 12 uH.

5. *Receiver Side Rectifier*: The receiver side voltage is assumed to be varying between 30V-70V based on the distance between the transmitter and receiver, same expressions are used to find the value of the filter capacitor. Output of the rectifier is found to be around 40V.
6. *Buck Converter (Chopper)*: The main elements of the Buck converter circuit are diode, inductor, capacitor, pulse generating circuit and MOSFET switches. Output of the buck converter is given by, $V_{\text{out}} = D.V_n$ where D = duty cycle. Assuming 50% duty cycle with $V_{\text{in}} = 40\text{V}$, $V_{\text{out}} = 20\text{V}$. Output current $I_{\text{out}} = V_{\text{out}}/R$, assuming $R = 4.5\Omega$, $I_{\text{out}} = 4.3\text{A}$.

Inductance of the buck converter is given by,

$$L = \frac{V.D}{F_{\text{sw}} \Delta I_L} \quad (3)$$

Here $V = 40 \text{ V}$, F_{sw} = switching frequency = 15 kHz, $\Delta I_L = 4\%$ of output current = 0.2 Amp. Therefore, $L = 6.66 \text{ mH}$. $L = 5 \text{ mH}$ is chosen.

$$C = \frac{\Delta I_L}{8 F_{\text{sw}} \Delta V_{\text{out}}} \quad (4)$$

assuming 4% voltage ripple = 0.8V, $C = 2\mu\text{F}$.

Other components chosen for simulation purpose are listed in Table 1.

1. *Proportional-Integral (PI) Controller*: P-I controller is mainly used to eliminate the steady state error resulting from Proportional (P) controller. However, in terms of the speed of the response and overall stability of the system, it has a negative impact. This controller is mostly used in areas where

speed of the system is not an issue. Since P-I controller has no ability to predict the future errors of the system it cannot decrease the rise time and eliminate the oscillations. If applied, any amount of I guarantees set point overshoot. In this work, self tuning technique for designing PI controller is used. It is observed that a constant voltage for the input range of 30V to 70V was achievable.

Table 1
List of components

Section	Element	Specification	Reason
Rectifier (Transmitter Side)	Diode	FR306A	Capability to switch at higher frequency
	Filter Capacitor	20 μ F, 150V	Voltage rating is chosen to give output voltage of 100V
Inverter	MOSFET	IRF640	Can handle until 500kHz switching frequency at 300V, 18A
Pulse generation Circuit	Pulses required for inverter switches	Arduino Board and TLP250	TLP250 is used for isolation and its operating frequency is 500kHz
Rectifier (Receiver Side)	Diode	FR306A	Higher switching frequency
	Filter Capacitor	2 μ F, 100V	Output voltage is 40V
Buck Converter	Diode	FR306A	
	Inductor	5mH, Ferrite Core	Flux concentration can be increased and size of inductance reduces for ferrite core
	Capacitor	2 μ F, 100V	To reduce the voltage ripple at the load
	Pulse generator	15kHz	As per the design
	MOSFET	IRF640	Can handle until 500kHz switching frequency at 300V, 18A

3. RESULTS AND ANALYSIS

This section discusses the open loop and closed loop simulation results obtained for the proposed WPT system. Simulation is carried out in Matlab Simulink software.

AC input of 158V is fed to the rectifier circuit and an output of 99V is obtained with a ripple voltage of about 3% (varying between (98V-100V). Figure 2 shows the ripple in the output of rectifier. This output is fed to the inverter where the switches are operated at 50kHz frequency using a pulse generator circuit. The circuit of the transmitter side, receiver side buck converter is shown in Figure 3 and Figure 4 respectively.

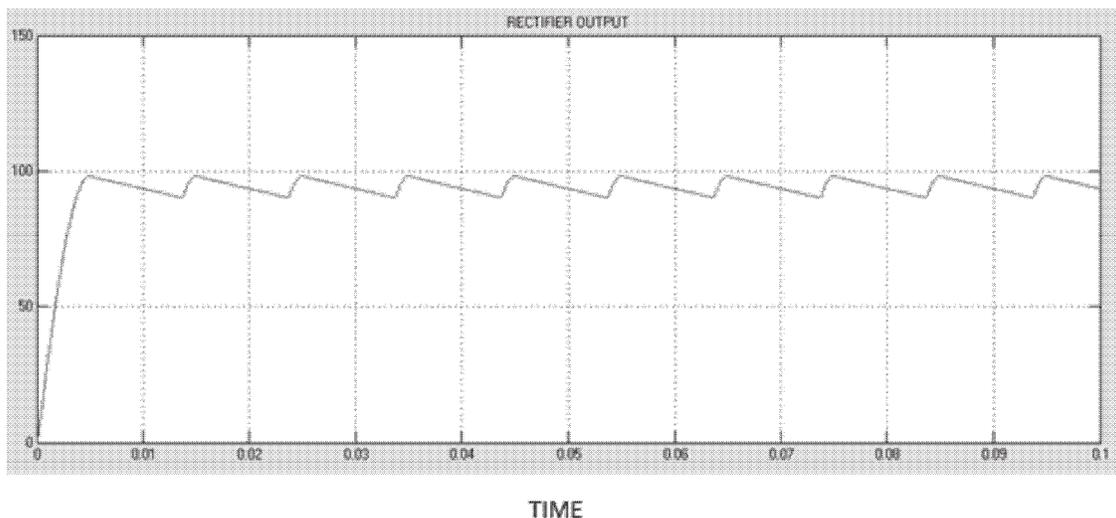

Figure 2: Output of Diode Rectifier (transmitter Side)

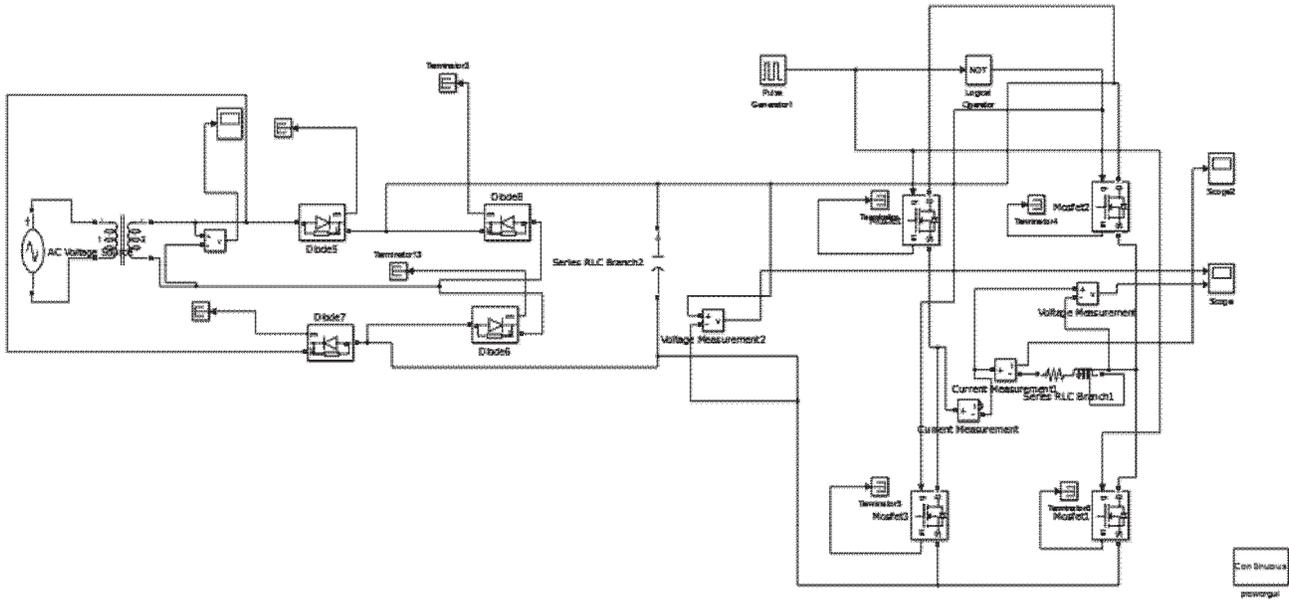

Figure 3: Transmitter Side Complete Circuit

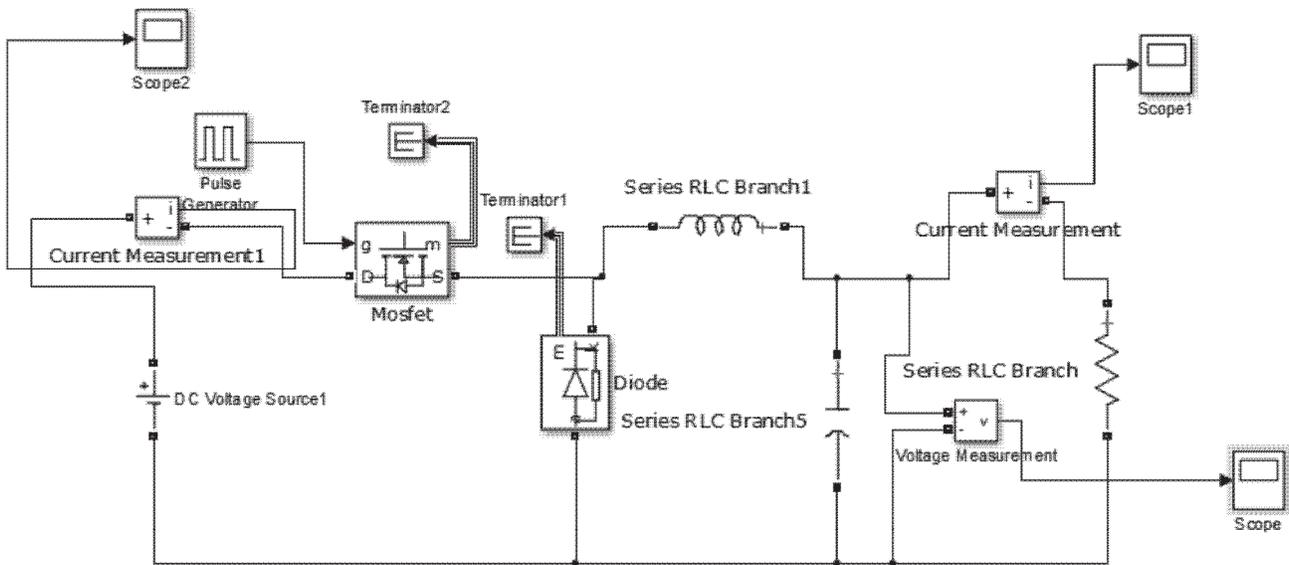

Figure 4: Buck Converter (Chopper) Circuit (Receiver Side)

The open loop simulation results of the various stages is shown in Figure 5 where a transmitting voltage of $\pm 99\text{V}$ and a receiving voltage of $\pm 48\text{V}$ is observed. Both these signals have a frequency of 50kHz . Receiver side rectifier output is obtained as 40V which is fed as input to the buck converter stage. The output from the buck converter was found to be 19V and an output current of 4.3A is obtained. Voltage and current output of the buck converter with a better resolution is shown in Figure 6 and Figure 7 respectively. The open loop simulation circuit with transmitter and receiver side is shown in Figure 8.

Further, the effect of input variation is observed in the simulation result to understand the importance of a controller at the receiver side. While changing the input voltage from 30V to 50V resulted in an output voltage variation from 14V to 25V and output current variation between 3.1A - 5.4A . The input to the chopper is assumed to be varying when the distance between the two coils are varied. Figure 9 shows the simulation result for varied input.

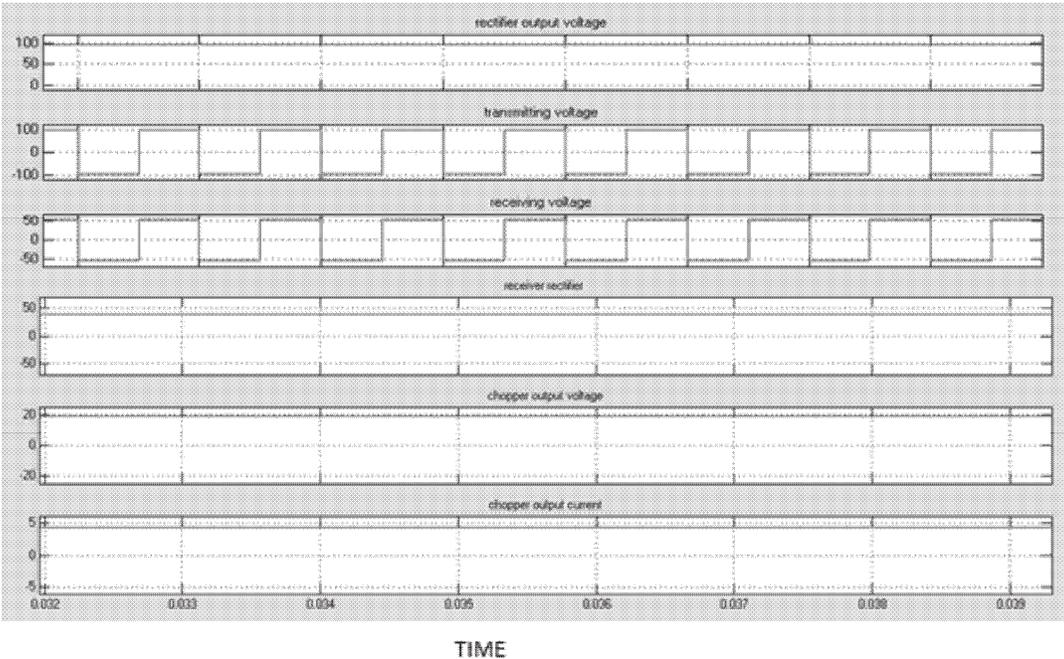

Figure 5: Open Loop Simulation Result

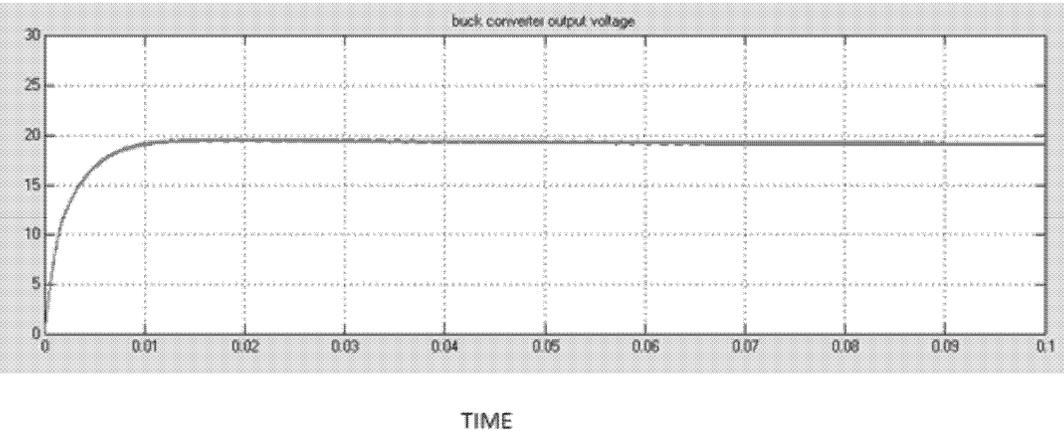

Figure 6: Buck Converter (Chopper) Output Voltage

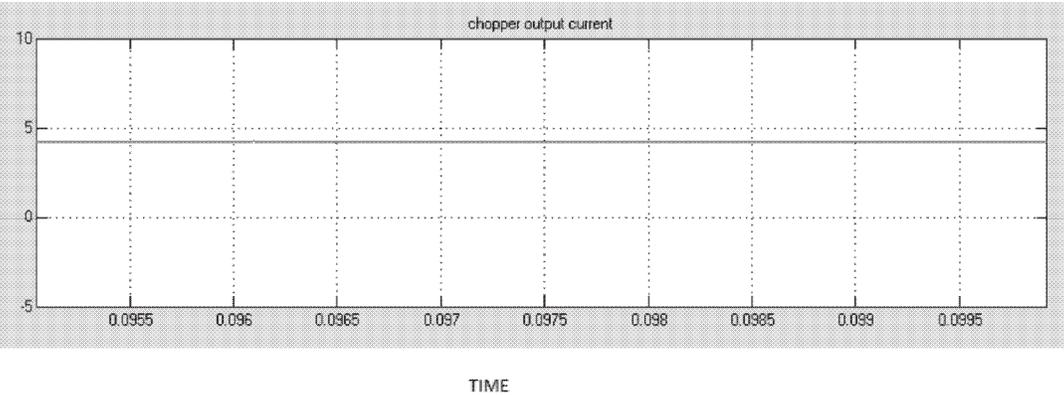

Figure 7: Buck Converter (Chopper) Output Current

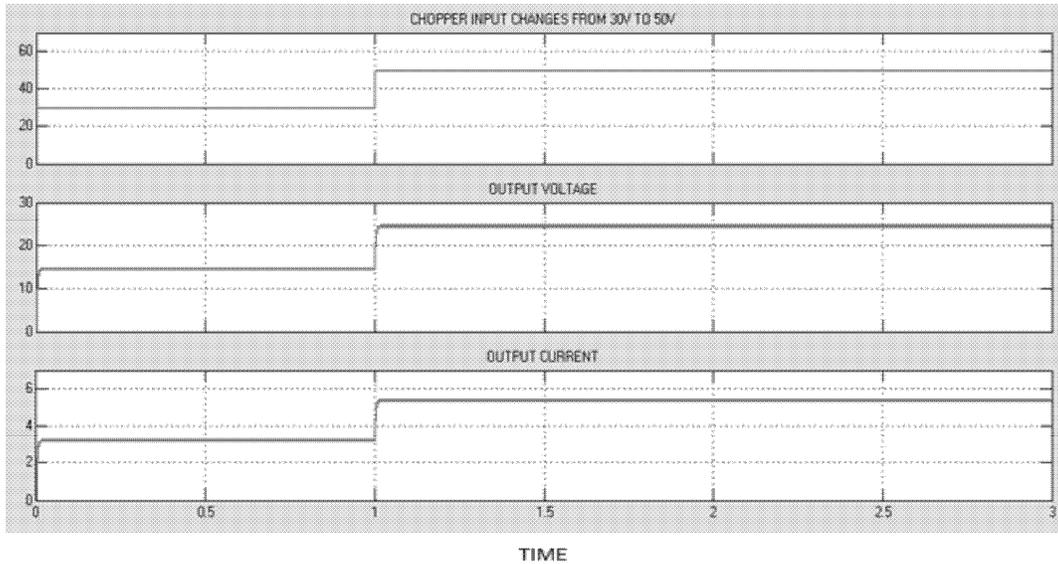

Figure 8: Open Loop Simulation Result for Change in Input Voltage

To overcome this problem a closed loop circuit is designed using P-I controller at the receiver stage and is shown in Figure 10. The auto tuning method available in simulink is used to obtain the controller parameters K_p and K_i . The simulation circuit for closed loop is shown in the Figure 11. It is observed that while using the controller, for a change in input to chopper from 30V to 50V, the output overshoots and settles to the constant voltage of about 19V. The settling time is about 5ms. Similar way, the output current also stabilizes to 4.3A.

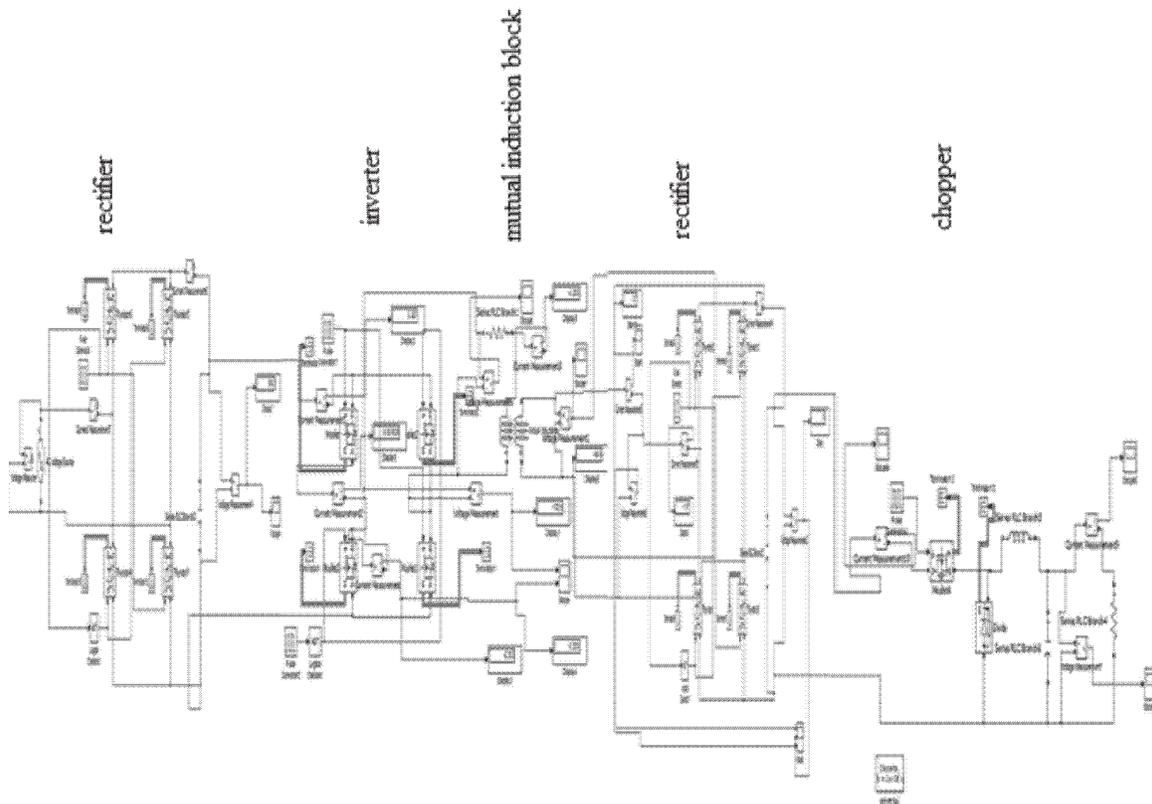

Figure 9: Over all Simulation Circuit (open loop)

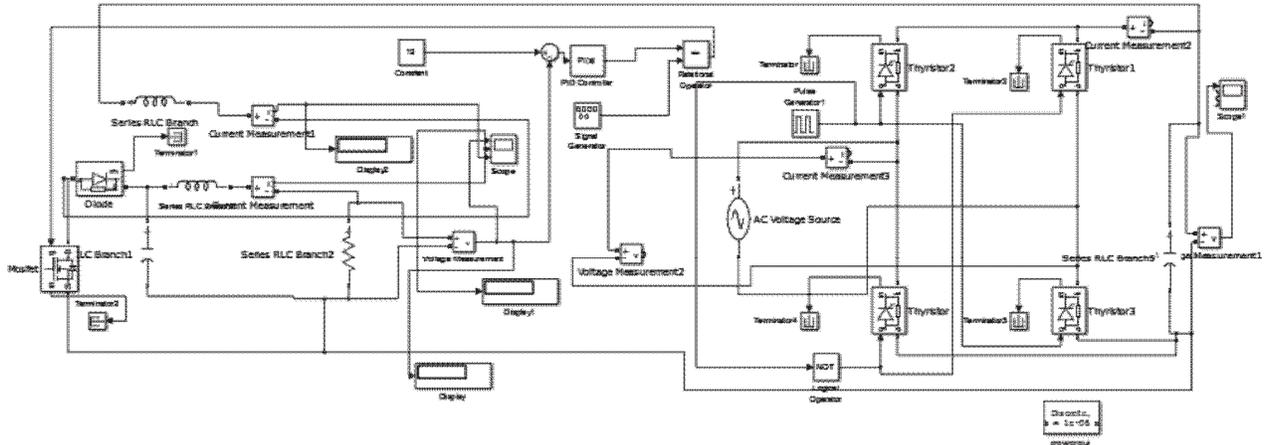

Figure 10: Closed Loop Circuit

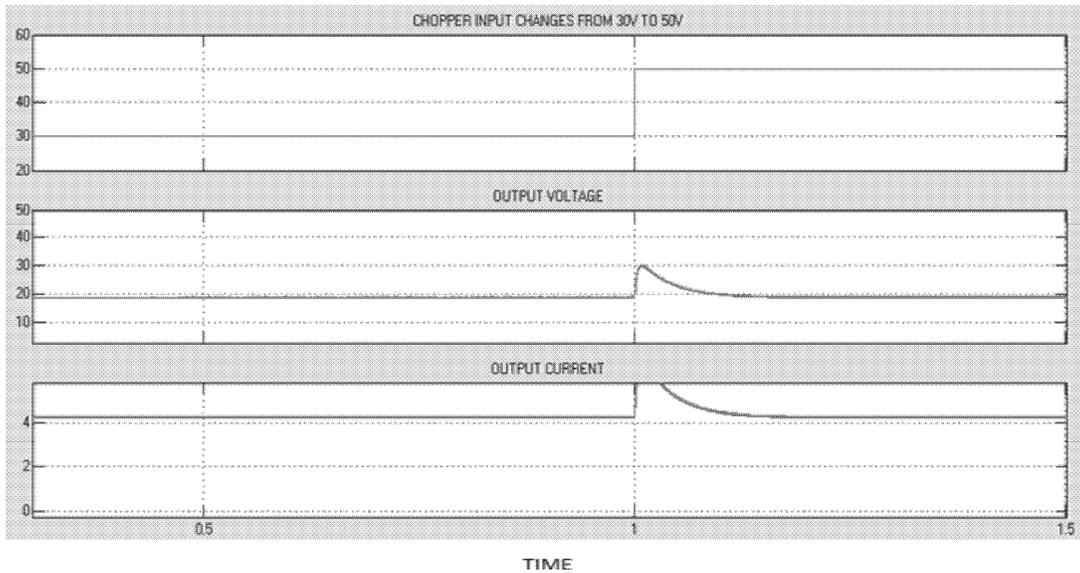

Figure 11: Closed Loop Simulation Result for Change in Input Voltage

4. CONCLUSIONS

The main motive behind taking up this work is to transmit the electric power for short distance through different mediums. It is possible to operate few equipment's like pace maker, submarines, drilling machines in deep mines, etc.

Design and simulation of a system for wireless power transmission is carried out to power a load at 20V, 4.5A. The circuit is simulated in Matlab Simulink software and an output of 19V, 4.3A is obtained. Further, the voltage transmission efficiency of wireless transmission depends on the various factors such as the distance between the coils, frequency of transmission and other environmental conditions. A closed loop circuit using PI controller is designed at the receiver side to mitigate the voltage fluctuations for varied distance between the two coils. With auto tuning facility of the Simulink software the PI controller is tuned so as to maintain the load voltage constant for varied distance ($k = 3 \text{ cm} - 10 \text{ cm}$) between the transmitter and receiver coils. The variation in distance is introduced by changing the coupling coefficient between the coils. Hardware implementation of the proposed design is planned in future.

REFERENCES

- [1] Kurs, Andre, Aristeidis Karalis, Robert Moffatt, John D. Joannopoulos, Peter Fisher, and Marin Soljacic, "Wireless power transfer via strongly coupled magnetic resonances", *Science*, vol.317, no.5834, pp. 83-86, 2007
- [2] Zhu, C., Liu, K., Yu, C., Ma, R., & Cheng, H., "Simulation and experimental analysis on wireless energy transfer based on magnetic resonances", *In 2008 IEEE Vehicle Power and Propulsion Conference (VPPC'08)*, pp. 1-4, 2008
- [3] Shoki, H. "Issues and initiatives for practical use of wireless power transmission technologies in Japan" *2011 IEEE MTT-s International Microwave workshop series on Innovative Wireless power transmission: technologies, Systems, and Applications*, pp. 87-90, 2011.
- [4] Sibakoti, Mandip Jung, and Joey Hamblin, "Wireless Power Transmission Using Magnetic Resonance", *IEEE International Conference on Magnetics*, pp. 2685-2698, December 2011.
- [5] Bou Balust, Elisenda., "Resonant inductive coupling wireless power transfer" *Proceedings of the 2012 Barcelona Forum on Ph. D. Research in Communication and Information Technologies*, October 15th, 2012.
- [6] Fareq, Mohd, M. Fitra, M. Irwanto, Syafruddin Hasan, and M. Arinal., "Low wireless power transfer using Inductive Coupling for mobile phone charger", *In Journal of Physics: Conference Series*, vol. 495, no.1, pp. 012-019, 2014
- [7] Yan, Z., Li, Y., Zhang, C., & Yang, Q., "Influence Factors Analysis and Improvement Method on Efficiency of Wireless Power Transfer Via Coupled Magnetic Resonance", *IEEE Transactions on Magnetics*, vol. 50, no.4, pp.1-4, 2014.
- [8] Mendes Duarte, R., & Klaric Felic, G., "Corrigendum to "Analysis of the Coupling Coefficient in Inductive Energy Transfer Systems", *Active and Passive Electronic Components*, Jan 1, 2016.
- [9] Ria George, M. Sreekala, and K. Deepa., "Single-Stage Boost Rectifier for Wireless Charging of Portable Devices Through Magnetic Resonant Coupling", *In Artificial Intelligence and Evolutionary Computations in Engineering Systems, Springer India*, pp. 443-452, 2016
- [10] T Rohith, Samhitha, Mamatha I., "Wireless Transmission of Solar Power using Inductive Resonant Principle", *2016 IEEE International Conference on Power and Energy Systems: Towards Sustainable Energy*. pp. 1-6, 21st-23rd Jan 2016: