

International Journal of Control Theory and Applications

ISSN : 0974-5572

© International Science Press

Volume 9 • Number 47 • 2016

Modelling of Engine Gimbal Control System

Jithina P. K., Anooja Sankar, Clint Augustine and Ashline George

Department of Electronics and Instrumentation, Kannur, Vimal Jyothi Engineering College, Kannur university, India
E-mail: jithinapk120@gmail.com

Abstract: An engine gimbal control system (EGCS) is usually used in spacecraft system for motion control. In rockets thrusters are used to provide attitude control. An EGCS is capable of providing torque with which rotation can be controlled (yaw, roll & pitch). This actuator helps in the movement of the thruster. Motion control is established by swivelling the thrusters in the desired direction. Runge – kutta integration method is used to solve the governed differential equations. Accordingly the system model is developed on MATLAB environment. By controlling the actuator, engine deflection is controlled.

Keywords: Engine Gimbal Control System, Runge-Kutta Method, torque motor, control system)

I. INTRODUCTION

In spacecrafts motion control is an inevitable factor. There are no of factors that affect its motion, such as effects due to aerodynamic forces, changing weather conditions etc. EGCS usually use combinations of small and large (vernier) thrusters, to allow dissimilar levels of response. Spacecraft engine gimbal control systems are used for controlling attitude during re-entry, for station keeping in orbit, for controlling orientation. Since spacecraft contain only fuel of finite amount there is small chance to fill-up them, some alternate EGCS have been recognized to conserve fuel. Air-launched Rocket Attitude Control of Separation Stage Based on RCS by TANG Shuo[1]. In this work he first studied movement under dissimilar separation conditions between plane and launch rocket, then found out status of launch vehicle flight when fired RCS. C. Toumes in his paper upper stage rocket guidance and control using discontinuous reaction control thrusters via sliding modes, studied about the design of the Guidance and Control Subsystem(GK) and the avionics system, [2]. In his work he presents the architecture of the G&C, and designed algorithms. Here discontinuous nature was exhibited by the attitude thrusters used in the RCS. Output Tracking Sliding Mode technique used the proposed design. The proposed execution of the design changes the outdated high frequency relay switching by a Smoothing Sliding Mode Controller. He established that a robust and accurate tracking of the spacecraft velocity and attitude was achieved by the Sliding mode.

Reaction Control System using Hybrid micro thrusters for Guided Sounding Rocket by Adrian Chelaru[3]. This paper calculus model for an advanced Reaction Control System (RCS) using hybrid rocket

engine technology was developed. Several hybrid micro-thrusters were used by the RCS, where separate control systems were used for thrust modulation. Each of the thrusters are made to burn a few minutes for RCS and by controlling the oxidizer flow the thrust will be modulated. A single oxidizer tank will be used to decrease weight and size of the RCS, which will be having a flow distributor output. Here idea is to minimize their thrust decreasing the oxidizer flow without halting any of the engines during system's operation.

In Apollo experience report lunar module reaction control system by Chester A. Vuughun, Robert Villemarette [4]. The Apollo spacecraft consist of the service module (SM) the lunar module (LM) and the command module (CM). The NASA Space Task Group unconfined the first statement of work for the SM and the CM in July 1961. The lunar module RCS was veined very closely after the service module reaction control system. Components common to the lunar module RCS and the service module and reaction control system were used where possible. Similar technology was used in the progress of the lunar module RCS.

II. SYSTEM DESCRIPTION

(A) Engine gimbal control system

A gimbal is a pivoted support that permits the rotation of an object about a single axis. A significant feature of rocket flight is control of the rocket and stability. Aerodynamic forces are used to deliver some measure of flight stability by the Stomp rockets, bottle rockets and model rockets. But these types of toy rockets do not have any other system for flight control. A full scale rocket is designed to successfully complete its mission, with systems for both control and stability. The Guidance system usually contains erudite computers and sensors to spot location, the orientation, and speed of the rocket.

Early rockets, and some air-to-air missiles, like the elevators on an airplane used movable aerodynamic surfaces. Later on rockets were intended to exit the atmosphere using minor vanes in the nozzle exhaust to vector the thrust. In most modern rockets like the Saturn V moon rockets and the Space Shuttle a system called gimballed thrust is used. Using a gimballed thrust system, the exhaust nozzle of the rocket can be swivelled from side to side, the direction of the thrust will be altered relative to the center of gravity of the rocket, as the nozzle is moved.

An engine gimbal control (EGCS) system uses an electromechanical actuator. It has a combination armature controlled DC torque motor and gear drive system. The gear system used here is a three stage speed reducer gear. The engine used here is very heavy, so high torque is required. This high torque requirement is satisfied using the gear system. The input torque is increased by twelve times. The actuator broadly comprises of an actuation unit and a sensor unit. The sensor unit consist of a rotary potentiometer, and it gives a direct output of the deflected angle.

The servo electronics completes the control loop. It receives the command of 0 to 6 V range from the on board processor and the feedback signal from the actuator, and thus generates the drive to the DC Torque Motor in the actuator. The servo electronics implement a lead-lag compensator. The EGCS block diagram is shown in fig. 1.

(B) DC torque motor

The Direct Drive DC torque motor is a servo actuator which can be openly fixed to the load it drives. It has a wound armature and a permanent magnet (PM) field which works together to translate electrical power to torque. This torque can then be used in speed control systems or positioning. For servo system applications direct drive torque motors are particularly suitable where it is necessary to reduce size, power, response time and weight, and to exploit position accuracies and rate.

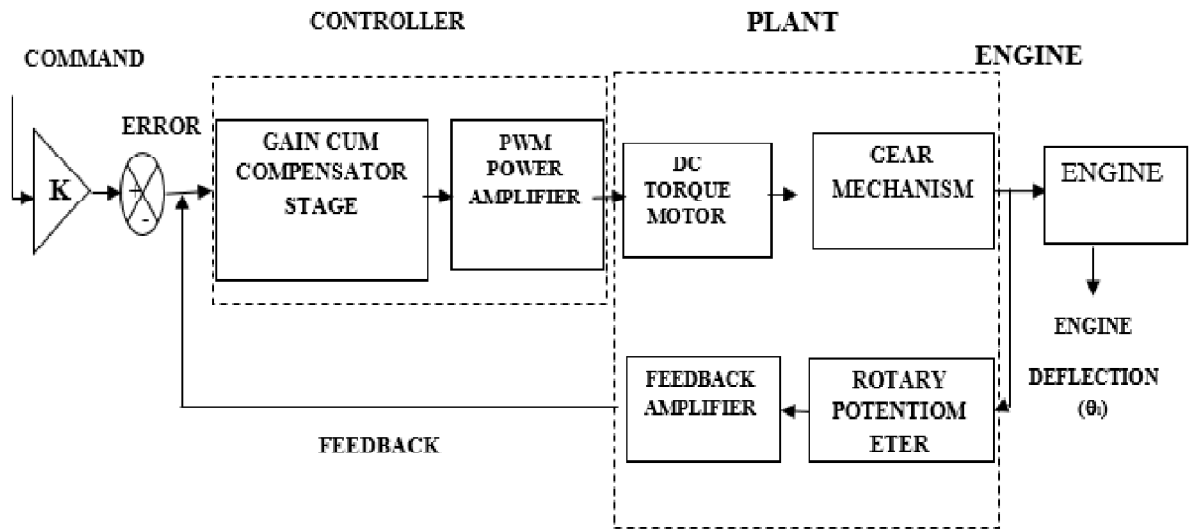

Figure 1: EGCS servo loop Block diagram including engine

(C) Gear mechanism

Gear drive is used here to satisfy the torque requirement. Since the thruster is too heavy high torque is needed to move the thruster. The speed input from the motor is reduced by gear trains. The torque is increased to twelve times as per the requirement. The system involves 3 stage gears.

(D) Rotary potentiometer

The feedback sensor used here is a rotary potentiometer. It produces a voltage output proportional to the rotation of the shaft. This output voltage is given as feedback voltage to the error detector.

3. ACTUATOR MODELLING

An actuator is a type of motor that is accountable for controlling or moving a system or mechanism. In our system the actuator used is an armature controlled DC torque motor. The field current is kept constant, and the armature current is controlled by varying the armature voltage V , in an armature controlled DC motor. The torque increases linearly with the armature for the motor.

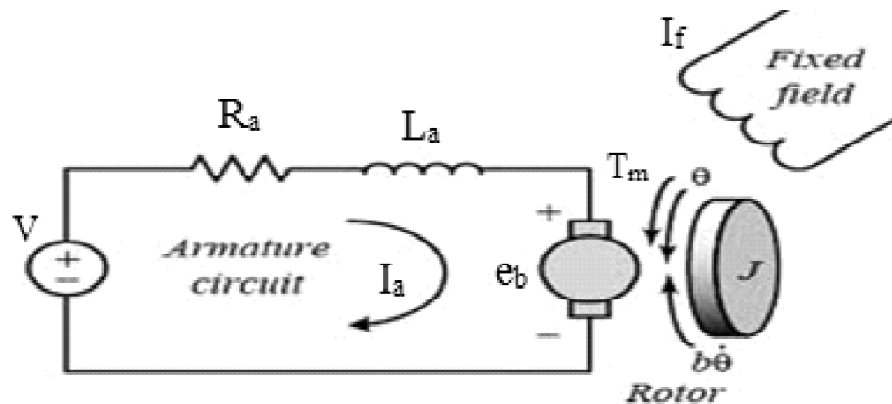

Figure 2: Armature controlled DC motor

L_a – Armature winding Inductance (H)

R_a – Armature resistance (ohm)

V – Applied armature voltage (V)

I_a – Armature current (A)

I_f – Field current (A)

e_b – Back emf (volts)

T_m – Motor torque (Nm)

θ – Angular displacement of motor shaft (rad)

$\dot{\theta}$ – Angular velocity of motor shaft

J – Equivalent moment of inertia of the motor and load referred to motor shaft ($\text{kg}\cdot\text{m}^2$)

B – Friction coefficient of the motor and load referred to motor shaft $\left(\frac{\text{Nm}}{\text{rad/sec}}\right)$

The DC motors are generally used in linear range of magnetization curve, in servo applications. Therefore, the air gap flux Φ is proportional to the field current i.e

$$\Phi = k_f I_f \quad (1)$$

Where k_f is a constant

The torque T_m developed by the motor is proportional to the product of the air gap flux and armature current, i.e

$$T_m = k_t k_f I_f I_a \quad (2)$$

Where k_t is a constant

Usually in the armature controlled DC motor the field current is kept constant, so the equation (5.2) can be written as

$$T_m = k_t I_a \quad (3)$$

Where k_t is the motor torque constant

The back emf of the motor being proportional to speed is given as

$$e_b = k_b \frac{d\theta}{dt}$$

$$e_b = K_b \omega \quad (4)$$

where k_b is the back emf constant

The armature circuits differential equation is

$$V_a = R_a I_a + L_a \left(\frac{dI_a}{dt}\right) + e_b \quad (5)$$

Laplace transforms of Equation (5) gives

$$V_a(s) - K_b \omega(s) = (R_a + sL_a) I_a(s) \quad (6)$$

An equation relating the rotational motion of the inertial load is got by summing moments

The torque equation is

$$T_m = J\dot{\omega} + B\omega \quad (7)$$

The transfer function of the motor torque input to rotational speed changes is

$$\frac{\omega(s)}{T_m(s)} = \frac{(1/J)}{s + (B/J)} \quad (8)$$

Equations (3), (6) and (8) together can be denoted by the closed loop block diagram shown below.

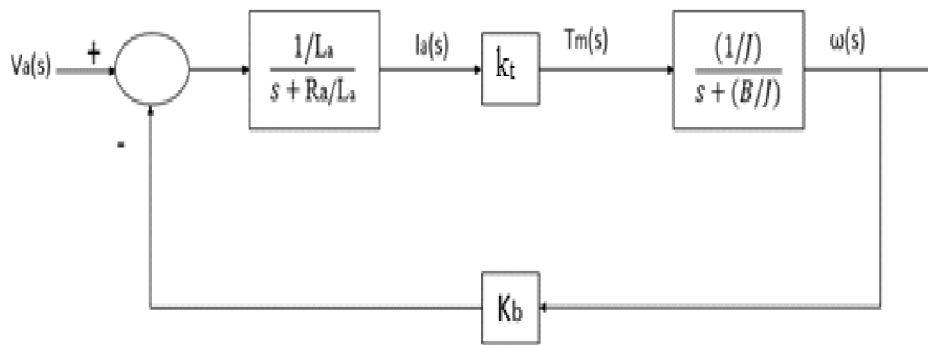

Figure 3: Armature controlled DC motor Block diagram

The inductance and armature resistance of the motor are represented in the model. The effect of back emf on the motor operation is represented as the negative feedback to match the speed – torque requirements of load.

4. MODELLING OF ELECTROMECHANICAL ACTUATOR

Motor output is given to the gear system. Geared system are usually used as speed reducer or in systems where high torque is required to move heavy system. The motor armature resistance and inductance are depicted in the model. Gear mechanism is employed between the prime mover and the thruster as a reduction gear which transfers the load from prime mover to thruster. The gear used here is a three stage gear with a gear ratio 1/12. This implies the speed is reduced by twelve times and the torque is increased by twelve times. The governed differential equations of the system is solved using runge – kutta integration method.

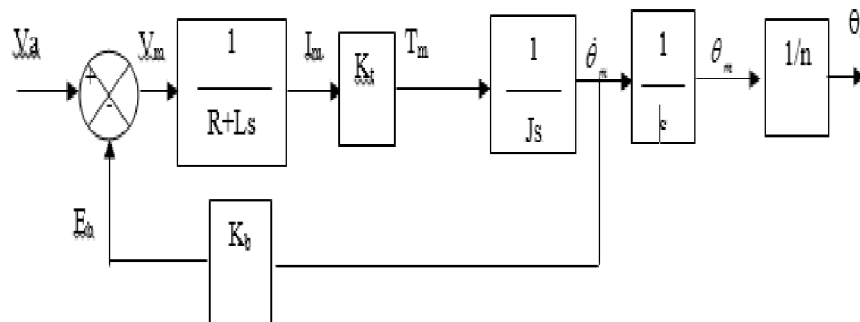

Figure 4: Block diagram of electro-mechanical actuator

5. GIMBAL ENGINE MODELLING

1. The load acting on the engine-actuator level during operation comprises of

- a) Load due to thrust misalignment
- b) Load due to hose stiffness
- c) Load due to bearing friction
- a) Load due to thrust misalignment :

The engine thruster will be swiveling according to the input from the actuator. When the propellant enters the combustion chamber, burning of propulsion takes place at high pressure. In the nozzle this chemical energy is converted into kinetic energy. The thrust force produced during operation will exert a small amount of deflection of the engine from current position. Thus due to thrust extra load will be generated which is included in modelling.

- b) Load due to hose stiffness: The hose is used to supply fuel to the combustion chamber. Due to propellant flow and stiffness of the hose extra load come into action which should be considered during operation.
- c) Load due to bearing friction : During operation friction effect of bearing also account for extra load on the engine.

The fig 5 shows the block diagram of engine gimbal control system.

Characteristics of the motor is represented using the conventional equation.

Equation for actuator level

$$\frac{J_m d^2 \theta_m}{dt^2} + B_m \frac{d\theta_m}{dt} = T_m \quad (9)$$

Taking laplace transform of eqn (9) and simplifying we get

$$E_b = K_b \times \dot{\theta}_m(s) \quad (10)$$

$$I(s) = \frac{V - E_b(s)}{R + Ls} \quad (11)$$

$$T_m(s) = K_t \times \frac{(V - E_b)}{R + Ls} \quad (12)$$

$$\theta_m(s) = \frac{T_m(s) - T_d(s)}{J_m s^2 + B_m s} \quad (13)$$

$$\theta_a(s) = \theta_m(s) \times \frac{1}{n}$$

Engine Level

$$\frac{J_m d^2 \theta_m}{dt^2} + B_m \frac{d\theta_m}{dt} + T_n = T_m \quad (14)$$

$$T_n = k_s (\theta_a - \theta_n) / n \tag{15}$$

T_m - Generated Torque

q_m - Rotor angular deflection

θ_a - Actuator angle deflection

$$J_n \frac{d^2 \theta_n}{dt^2} + B_n \frac{d\theta_n}{dt} = T_d + K_s (\theta_a - \theta_n) \tag{16}$$

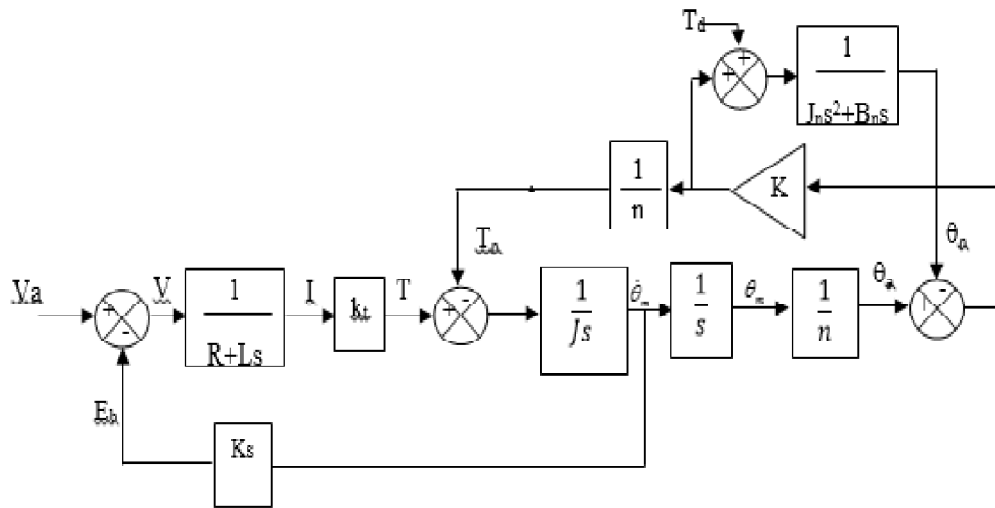

Figure 5: Block Diagram of Engine Gimbal Control System

(A) Output Sensor

Feedback sensor used here is rotary potentiometer. It produces a voltage output corresponding to the input deflection in the angle. The sensor output is scaled and fed to the negative input of the input error amplifier.

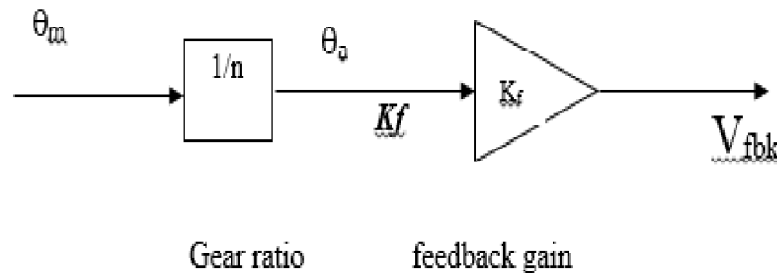

Figure 6: Feedback Sensor unit

6. NUMERICAL ANALYSIS USING RUNGE KUTTA INTEGRATION

The Runge–Kutta methods are an important family of explicit and implicit iterative methods in numerical analysis, which are used in ordinary differential equation’s temporal discretization for the approximation of solutions . The differential equations of the system are solved using the Runge - kutta integration method.

Motor current

$$\frac{I_m}{V_m} = \frac{1}{R + L_s}$$

$$RI_m + LI_m = V_m$$

$$\dot{I}_m = \frac{V_m - RI_m}{L}$$

Motor speed

$$\frac{\dot{\theta}_m}{T_{net}} = \frac{1}{J_m s + B_m}$$

$$J_m \ddot{\theta}_m + \dot{\theta}_m B_m = T_{net}$$

$$\dot{\omega}_m = \frac{T_{net} - \omega_m B_m}{J_m}$$

Engine

$$J_n \ddot{\theta}_n + B_n \dot{\theta}_n = T_d + K_s (\theta_a - \theta_n)$$

$$J_n \dot{\omega}_n + B_n \omega_n = T_d + K_s (\theta_a - \theta_n)$$

$$\dot{\omega}_n = \frac{T_d + K_s (\theta_a - \theta_n)}{J_n}$$

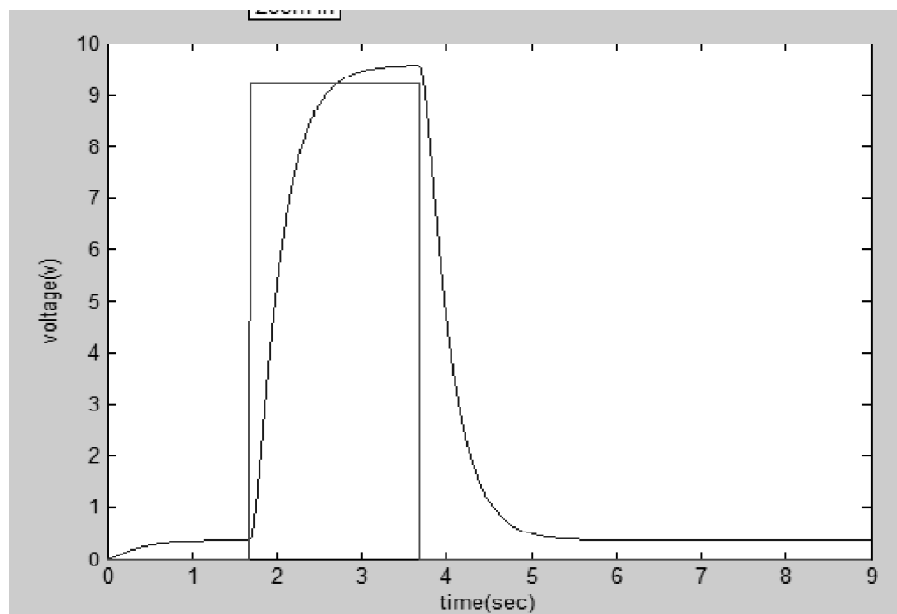

Figure 6: Response of uncompensated system for 6v step input

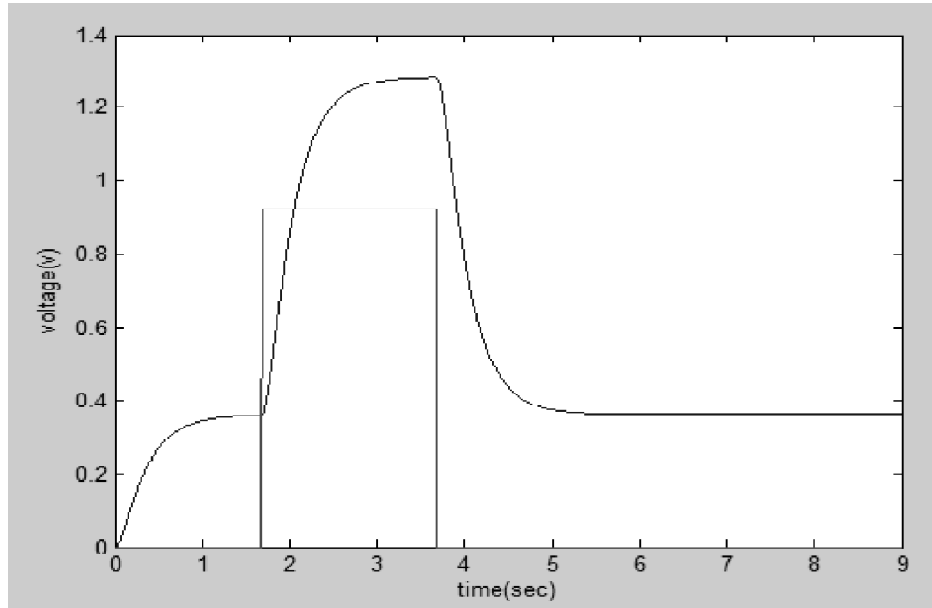

Figure 7: Response of the uncompensated system with 0.6v input

8. COMPENSATOR DESIGN

The control system is designed to perform specific tasks. The requirement of control system are usually specified as performance specifications. The specifications are generally related to relative and speed of response stability and accuracy.

The first step in design is the adjustment of gain to meet the desired specifications shown in table1. In practical systems modification of gain alone will not be enough to meet the given specifications. In many cases increasing the gain may result in poor instability or stability. In such cases, it is essential to change the behavior and to encounter the desired specifications. Compensator used here is a gain come lead lag compensator.

(A) Design steps

In EGCS improvement in both transient state and steady state is required. So lead – lag compensator is used. In actual designing the gain value is tuned 1st. Then to improve the transient response and to meet the bandwidth requirement lead compensator is tuned. Finally the lag compensator is set to improve the steady state requirement.

The servo electronics comprises of the error amplifier, 2 stages of compensator and PWM power amplifier gain. In PWM the output of the gain stage is compared with a ramp signal and generates the PWM signal. The PWM output drives the H-type power amplifier and the amplifier output drives the torque motor in actual system. But in modelling we consider only the compensator stage and the PWM gain. Power amplifier gain is estimated from the experimental contour of command Vs Actuator voltage with feedback path open. Power amplifier gain

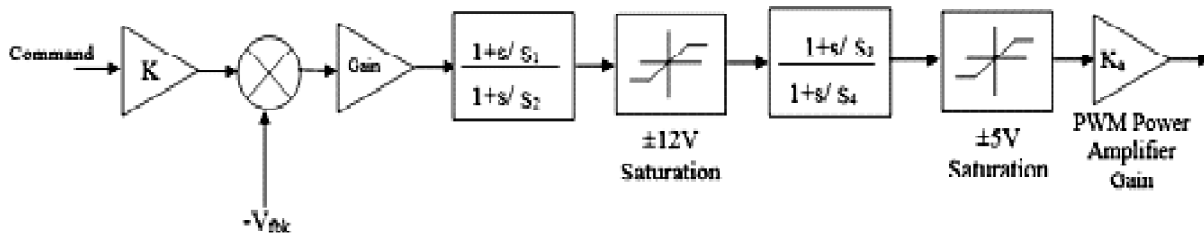

Figure 8: Block diagram of compensator

is implemented as a 1-D lookup table between error voltage and amplifier gain. The poles and zeros of lead lag compensators are found out by trial and error method. V_a the actuator voltage = Gain * G_1 * G_2

7. VALIDATION RESULTS

The validation of the model is done by analyzing the output of the model with selected input command. The model output must satisfy the given specification. Both step input and sinusoidal input is given to the system. The step and frequency response of the system is analysed. The validation results are shown below.

(A) Step response of the system

The models are subjected to the following step input. Results are shown below. The required specifications and the result obtained are included below. The response is taken from the potentiometer feedback. The response plot is between the time and potentiometer voltage which indicate the rotation of the actuator shaft. By controlling the actuator to the required specification the engine deflection can be controlled.

step input

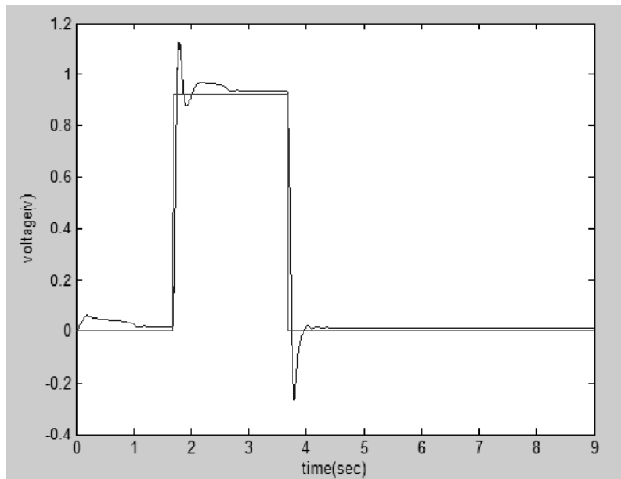

Figure 9: Step Response of compensated system for 0.6v

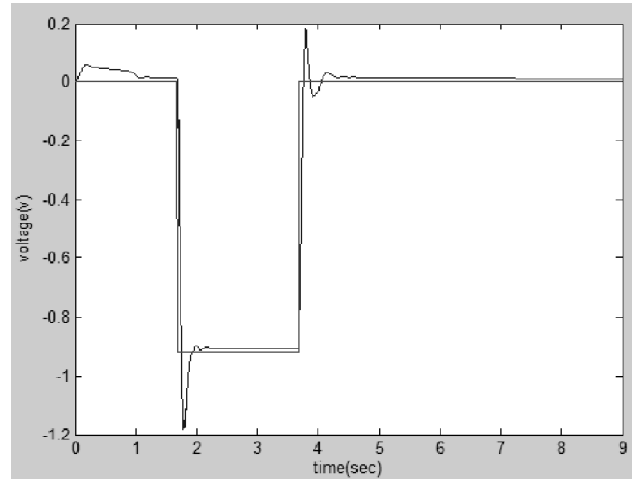

Figure 10: Response of compensated system for -0.6v step input

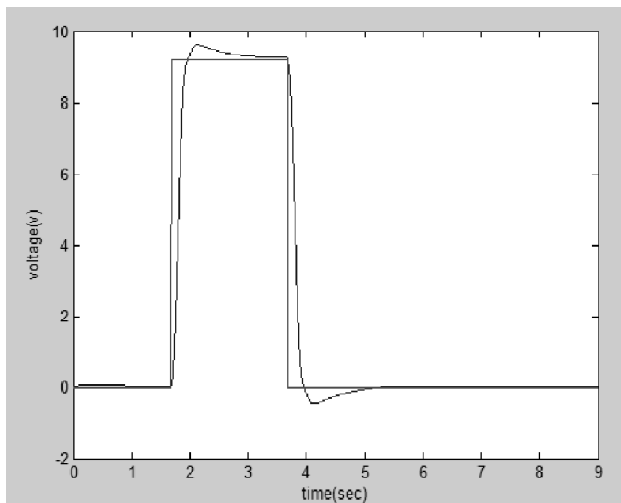

Figure 11: Response of compensate for 6v step input

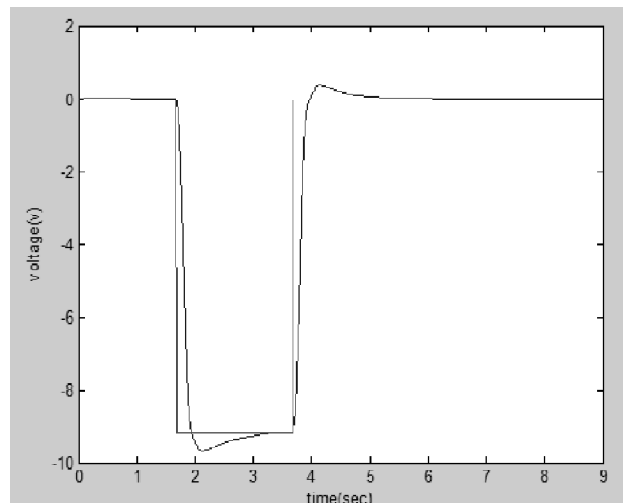

Figure 12: Response of compensated system for -6v step input

(B) Frequency response of the system

10% command - 3db – 5.25 – 7.25 hz
- 90deg bandwidth 3.5 to 5.25hz

100% command- 3db – 1 – 2 hz
- 90deg bandwidth 2.25 to 3 hz

Maximum steady state error % less than 1.5 %

Position accuracy less than 3

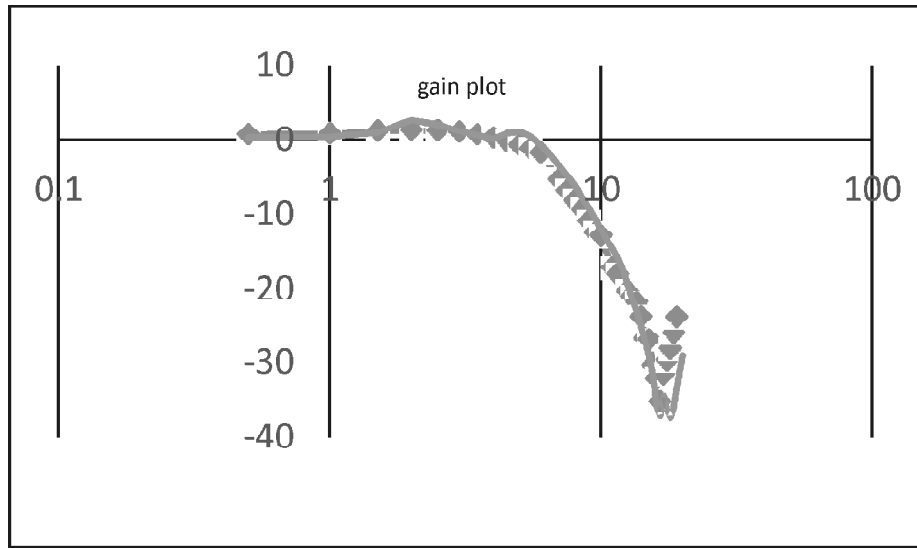

Figure 13: Gain plot of model output and experimental output



Figure 14: Phase plot of model output and experimental output

Table 1
Step response specifications

Command	Simulated Response				Specifications			
	Rise Time (msec)	Fall Time (msec)	Settling Time (msec)	% Overshoot	Rise Time (msec)	Fall Time (msec)	Settling Time (msec)	% Overshoot
10 % Command								
0 to 0.6 V	56	56	168	20	45-105	45-105	<350	15-45
0 to -0.6V	55	55	169	20	45-105	45-105	<350	15-45
100% Command								
0 to 0.6 V	156	156	180	4	170-230	170-230	<475	<11
0 to -0.6V	157	157	181	4	170-230	170-230	<475	<11

8. CONCLUSION

Mathematical modelling of the engine gimbal control system (EGCS) is obligatory for checking the proper working of the system. Engine Gimbal Control System has a wide range of application in the research and space fields. This is a main control systems used in majority of rocket systems. It is used for controlling the yaw, pitch and roll of the rockets. Usually the rockets have different stages. Separate EGCS are provided for motion controls in different stages. So the peculiarity of EGCS at different stages are different. In this work a mathematical model and validation of EGCS is done. This EGCS system mainly focus on the roll control of rockets during launching. Roll control is essential since the chances of rockets to get collapsed due to directional change is more. So roll control is inevitable. For this the motion of two engine gimbal thrusters are controlled for achieving the required motions. The required control signal is given from the guidance package. With the help of electromechanical actuator the gimbal control thruster is moved

REFERENCES

- [1] XUZhi and TANG Shuo “Air-launched Rocket Attitude Control of Separation Stage Based on RCS”, *2010 3rd International Conference on Advanced Computer Theory and Engineering (ICA CTE)*.
- [2] C. Toumes and Y. B. Shtessel “Upper stage rocket guidance and control using discontinuous reaction control thrusters via sliding modes”, *Proceedings of the American Control Conference Albuquerque, New Mexico June 1997-7803-3832-4/97/1997 AACC*.
- [3] Teodor Viorel Chelaru, “Reaction Control System using Hybrid MicroThrusters for Guided Sounding Rocket”, *20 13 IEEE*.
- [4] Chester A. Vuughun and Robert Villemarette “Apollo experience report lunar module reaction control system”, *national aeronautics and space administration washington, d. C. March 1972*.
- [5] Artem A and Dyakonov “Design concerns and considerations for Mars entry vehicle RCS”.
- [6] Yingjing “RCS compound control design for near space vehicles”, *international journal of innovative computing, information and control, volume 8, number, K. Elissa, “Title of paper if known,” unpublished*.