



International Journal of Control Theory and Applications

ISSN : 0974-5572

© International Science Press

Volume 10 • Number 26 • 2017

Modelling of PID controller for AGC of a Multi-Area Power System with Thyristor Controlled Series Controller

K. Swetha¹, D. Vijaya Kumar² and V. S. Vakula³

¹ SRKR College of Engineering, Bheemavaram, Andhra Pradesh-532402, E-mail: swet07@gmail.com

² Aditya Institute of Technology and Management, Tekkali, Andhra Pradesh

³ JNTUK University college of Engineering, Vizianagaram, Andhra Pradesh

Abstract: The current study discusses the impact of non-linearities on “Automatic Generation Control (AGC)” problem with Thyristor Controlled Series Controller (TCSC) system. At the outset, a 3 area thermal power system is considered for investigation in presence of non linearities like “Governor Dead Band (GDB)” as well as “Time Delay (TD)”. In the next step, “Proportional Integral Derivative (PID)” controller is kept as secondary controller and the gains of the controller are optimized by using Bacteria Forging Optimization Algorithm (BFOA). Further, TCSC is incorporated in first area to improve the performance of the system. Finally, from the outcomes of the simulations, it reveals that the power system with TCSC performs better than without any TCSC.

Objectives: To control the frequency deviation efficiently so that it should be in the specified limits and also to show that Thyristor Controlled Series Compensator is better than the conventional methods while considering the non linearities like Governor Dead Band and Time delay

Methods: The methods employed are Particle Swarm Optimisation technique and Bacteria Forging Optimisation Algorithm for tuning the gains of the PID Controller

Findings: The system employed with TCSC performs better than the system does not containing the TCSC. TCSC employed system gives better results when we consider speed governor Dead band, Generation Rate Constraint and Time delay.

Improvements: The change in frequency is less in the areas consisting of TCSC when compared to other frequency Compensating techniques employed areas. So TCSC is a better choice for controlling the frequency deviation in LFC.

Keywords: Load Frequency Control; Thyristor Controlled Series Controller; Particle Swarm Optimization; PIDcontroller; Governor Dead Band; Transport Delay.

1. INTRODUCTION

In modern power system the main concern was about the control of power system even though there are some significant milestones in the evolution of the electric power which is due to demand increases day by day. The

primary goal of power system control is the maintenance of constant supply of power with an adequate quality, for all customers in the system. As AC form of power has both real as well as reactive elements, the balance between real as well as reactive power is to be attained. 2 fundamental control methods utilized for achieving reactive (adequate voltage profile) as well as real power balance (adequate frequency value). The first is known as “Automatic Voltage Regulator (AVR)”, while the second is known as “Automatic Load Frequency Control (ALFC)” or “Automatic Generation Control (AGC)” among which LFC is very important [1]. In an inter-connected power system an instantaneous load change in any area leads to deviation of frequency of every area as well as of tie-line powers which is to be adjusted for ensuring generation as well as distribution of electric power of sufficient quality and is attained with Load Frequency Control (LFC)”. The primary goal of LFC is the maintenance of steady frequency, controlling the tie-line flow, controlling frequency deviations through maintenance of real power balance in the system and distribution of load amongst participant generating units [2].

Almost all the previous work in the domain of LFC is with regard to inter-connected system as well as comparatively less focus is given to LFC of interconnected multi area system. Also little work has been done through consideration of physical limitations like “transport delay (TD)”, “Generation Rate Constraint (GRC)” as well as “Governor Dead Band (GDB)” non-linearity [3]. The stabilization of frequency oscillation is problematic as well as very anticipated in the upcoming competitive environments. The “Flexible Alternating Current Transmission System (FACTS)” devices are having the capability for overcoming above problems. As there are several types of FACTS devices such as “Static synchronous Compensator (STATCOM)” (shunt connected), “Static Synchronous Series Compensator (SSSC)” (series connected), “Static Var Compensator (SVC)”, (shunt connected), “Thyristor Controlled Series Capacitor or compensator (TCSC)”, “Interline Power Flow Controller (IPFC)”, “Unified Power Flow Controller (UPFC)” (combined shunt-series) [4]. In view of the above in the present study, an unequal three area system is considered and performance of system is analyzed in presence of TD, GDB, filter and TCSC. A comparative analysis was done in different cases, that is, with no delay, with delay as well as with TCSC.

In PID controller, the output consists of the properties of proportionality, Integrity and the derivative of error signal. For the proportionality block if the gain is very high system becomes unstable where as smaller gain results in very large input error. when an integral block present in the controller it speed up the response towards its final state and it also reduces the residual steady-state error when compared to the system only having the proportionality block. A Derivative control is useful when it have a constant error signal. Derivative control is not used alone because it effects the system stability.

Generation Rate Constraint

The power system is in equilibrium, if power demands as well as power generated are balanced. For the interconnected power system we do not include the effects of rate of deviation in power generation. Different generating sources have different deviations or changes in rate of power production. When there is a load demand there is a chance of an instruction to a power source to increase its power generation. When there is load shut down there is a chance of an instruction to a power source to decrease its power generation to meet the supply demand equilibrium. The increment or decrement of rate of change in power generation should follow some rate. Generally, it is a ramp rate. The Generation rate Constraint is nothing but the ramp rate limit.

Speed governor dead band

Dead band is the region where the output is zero. For a given position of the governor control valves, an increase /decrease in speed can occur before the position of the valve changes is the effect of speed governor. the system response can materially affected by the governor dead –band. The dead band can be significant in AGC studies, since relatively small signals are under considerations.

The nonlinear has been approved by linear characteristics in earlier analysis. By dead-band in the governor operation there is another non –linearity introduced. The governor dead band is caused by the mechanical friction

and backlash and also valve overlaps in hydraulic relays. Because of this the input signal increases, the speed governor may not immediately react until the input reaches a particular value. When the input signal decreases similar action takes place. The governor dead-band is specified as 0.06%. The speed governor control loop block diagram includes the effect of dead-band is shown in fig. If the worst case for the dead-band is considered and examining the dead-band block in fig. the following set of equations define the behaviour of dead band.

2. SYSTEM INVESTIGATED

In this paper, a multi area power system comprises three regions which are inter-connected by higher voltage transmission line or tie-line are considered. In multi-area power system, load changes affect frequencies of every control area. Hence, frequency deviation in areas may be the result of the mismatch power in the entire inter-connection not only in the control area. AGC system executed in every control area ought to be capable of managing as well as controlling exchanged power between control area and local frequencies. In various applications, the position and speed control can be easily done by varying the gains of the PID controller. The goal may be attained through addition of tie-line flow deviations to frequency deviations in feedback loop. Hence, area control errors that are linear combinations of frequencies as well as tie-line power deviation is utilized. All the three areas are having thermal units with different rating and to get the realistic concept, transport delay, governor dead band. A chebyshev-II filter is considered to reduce the harmonics in the system.

2.1. Particle Swarm Optimization (PSO) technique for tuning the gains of the PID Controller

PSO is proposed by Eberhart and by his Colleagues. The tuning of PID controller can be done by PSO so that the optimal performance can be ensured at normal operating conditions. The tuning of PARAMETERS PID gains in offline can be done by PSO. PSO is the best method because it does not have any assumptions or less assumptions during the arrival of the best solution. The PSO is an iterative method which finds the solution in a systematic procedure.

The Particle Swarm Optimisation technique is a natural process in which the movement of organisms such as group of bird movements. The initial swarm of particles represented by a matrix in search space is firstly produced by PSO. The candidate solution for each PID parameters is represented by each particle where they are ranges from 0 to 100. The position and velocity in a 3- dimensional problems are represented by matrices with dimension of 3 x swarm size. The number of the particle is the swarm size where 40 is considered as a lot enough. A good PID controller yields a good system response and minimization of performance index also be obtained. For a particular set of the gains the system response is good and that is the best solution that is obtained through Particle Swarm Optimisation technique.

2.2. Bacteria Forging Optimization Algorithm (BFOA)

The Bacterial Foraging Optimization Algorithm is based on the bacteria Behaviour of E.coli and M.xanthus. Mostly, the BFOA construction based on the behaviour of bacteria chemotaxis that it can aware of chemicals existing in the environment like nutrients and continuous its journey by taking some signals. For an specific signal it moves towards the destination and for other signal it may move away from it.

2.3. TCSC Model in LFC

TCSC does not have a power source but it can change the impedance of the transmission path, where it is situated which affects the power flow in a network. When we consider a multi area system, tie line powers also gets affected. It is well known that "Thyristor Controlled Series Compensator (TCSC)" is a series compensating device, it contains a fixed series capacitor in parallel with thyristor controlled reactor. Thyristor controlled reactor has a reactor in series with a bi-directional thyristor valve. The TCR can be fired in such a way that phase

angle ranges from 90 degrees to 180 degrees which helps to vary the impedance of TCSC. The impedance of TCSC can be represented in terms of firing angle, which can be modified by the gate signal applied to the thyristor. The reactance of the transmission line can be varied through adjustment of the firing angles of TCSC. TCSC is regarded as a variable reactance, whose value is fixed automatically for constraining the power flow over the branch to a particular value. The variable reactance X_{TCSC} denotes the net equivalent reactance of TCSC, if operating in inductive or capacitive mode [5]. [Figure 4] gives the schematics of a 2 area inter-connected thermal - thermal power system with TCSC linked in series with tie-line. For analysis, it is presumed that TCSC is linked close to the area 1. Resistance of tie-line is ignored, as the impact on dynamic performance is negligent. Furthermore, reactance to resistance ratio in a practical inter-connected power system is higher. The TCSC is used because it reduces the power variations from one area to another area.

Incremental tie-line power with no TCSC is expressed as (1).

$$\Delta P_{Tie12}(s) = \frac{2\pi T^0}{s} [\Delta F_1(s) - \Delta F_2(s)] \quad (1)$$

In this equation, ΔF_1 and ΔF_2 represents system frequency deviations, T^0_{12} the synchronising coefficient with no TCSC. The line current flows between area 1 and area 2 may be given by, if TCSC is linked in series with the tie line

$$I_{12} = \frac{|V_1| \angle(\delta_1) - |V_2| \angle(\delta_2)}{j(X_{12} - X_{TCSC})} \quad (2)$$

Where in X_{12} as well as X_{TCSC} represents the tie-line and TCSC reactance correspondingly.

The complicated tie-line power as

$$P_{Tie12} - j Q_{Tie12} = V_1^* I_{12} = |V_1| \angle(\delta_1) \left[\frac{|V_1| \angle(\delta_1) - |V_2| \angle(\delta_2)}{j(X_{12} - X_{TCSC})} \right] \quad (3)$$

$$P_{Tie12} = \frac{|V_1| |V_2|}{(X_{12} - X_{TCSC})} \sin(\delta_1 - \delta_2) \quad (4)$$

The tie-line power flow may be expressed with regard to % compensation (k_c) as

$$P_{Tie12} = \frac{|V_1| |V_2|}{X_{12} (1 - k_c)} \sin(\delta_1 - \delta_2) \quad (5)$$

Where $k_c = \frac{X_{TCSC}}{X_{12}}$; % age of compensation given by the TCSC

To get linear incremental model, the (8) may be expressed as

$$P_{Tie12} = \frac{|V_1| |V_2|}{X_{12} (1 - k_c)^2} \sin(\delta_1^0 - \delta_2^0) \Delta k_c + \frac{|V_1| |V_2|}{X_{12} (1 - k_c)^2} \cos(\delta_1^0 - \delta_2^0) (\Delta \delta_1 - \Delta \delta_2) \quad (6)$$

If $J^0_{12} = \frac{|V_1| |V_2|}{X_{12}} \sin(\delta_1^0 - \delta_2^0)$ and $T^0_{12} = \frac{|V_1| |V_2|}{X_{12}} \cos(\delta_1^0 - \delta_2^0)$, then Eq (6) is expressed as

$$\Delta P_{Tie12}(s) = \frac{J_{12}^0}{(1-k_C^0)^2} \Delta k_C + \frac{T_{12}^0}{(1-k_C^0)} (\Delta \delta_1 - \Delta \delta_2) \quad (7)$$

Since $\Delta \delta_1 = 2\pi \int \Delta F_1 dt$ $\Delta \delta_2 = 2\pi \int \Delta F_2 dt$ and

Laplace transforms of Eq. 7

$$\Delta P_{Tie12}(s) = \frac{J_{12}^0}{(1-k_C^0)} \Delta k_C(s) + \frac{2\pi T_{12}^0}{s(1-k_C^0)} (\Delta F_1(s) - \Delta F_2(s)) \quad (8)$$

From eq (8), tie-line power flow may be regulated through control of $\Delta k_C(s)$. If the control input signal to TCSC damping controller is presumed to be $\Delta Error(s)$ while the transfer function of the signal conditioning circuit is

$$k_C = \frac{K_{TCSC}}{1+sT_{TCSC}}, \text{ The expression is given (9)}$$

$$\Delta k_C(s) = \frac{K_{TCSC}}{1+sT_{TCSC}} \Delta Error(s) \quad (9)$$

Where in K_{TCSC} & T_{TCSC} are the gains as well as time constant of TCSC controller correspondingly. As TCSC is retained close to area-1, frequency deviation ΔF_1 can be adequately utilized as the control signal $\Delta Error(s)$, to the TCSC unit for controlling the % age increment change in the system compensation level. Hence,

$$\Delta k_C(s) = \frac{K_{TCSC}}{1+sT_{TCSC}} \Delta F_1(s) \quad (10)$$

$$\Delta P_{Tie12}(s) = \frac{2\pi T_{12}^0}{s(1-k_C^0)} [\Delta F_1(s) - \Delta F_2(s)] + \frac{J_{12}^0}{(1-k_C^0)^2} \frac{K_{TCSC}}{1+sT_{TCSC}} \Delta F_1(s) \quad (11)$$

3. RESULTS ANALYSIS

The schematic model of the system under present research given in [Figure 1 [6]] is built in MATLAB/SIMULINK. A 4% step load increased at a time in area 1. The system is studied in two cases. As the system is unequal three separate controllers are considered in all areas. The gains of PID controllers are optimized by using PSO optimization technique [7]. The optimal gain values are given in the [Table 1]. The PSO technique clearly explained. Initially, 0.04 pu.u. load disturbance and transport delay of 0.5 sec is considered. In next, TCSC is connected in area1 to improve the performance of the system. From the simulation results shown in [Figures 2 – 7] it reveals that, the system with TCSC performs better than without TCSC. The Change in frequencies (ΔF_1 , ΔF_2 , ΔF_3) with respect to time (in sec) in area 1, area 2, area 3, deviates more when the system does not contain TCSC when compared with system having Thyristor Controlled Series Compensator as shown in figures. The red dotted line indicates the performance without TCSC and the black continuous line indicate the system performance with TCSC. The tie line power between area 1 and area 2 is as shown in [Figure 5]. The tie line power between area 1 and area 3 is as shown in figure 6. The tie line power between areas 2 and area 3 is as shown in [Figure 7]. The arrangement of the area 1 is as shown in [Figure 1].

Table 1
Optimal gain values of PID Controller

Parameters	Area 1	Area 2	Area 3
K_p	0.7049	0.6418	0.5493
K_i	0.4249	0.4750	0.5434
K_d	0.2850	0.2693	0.5336

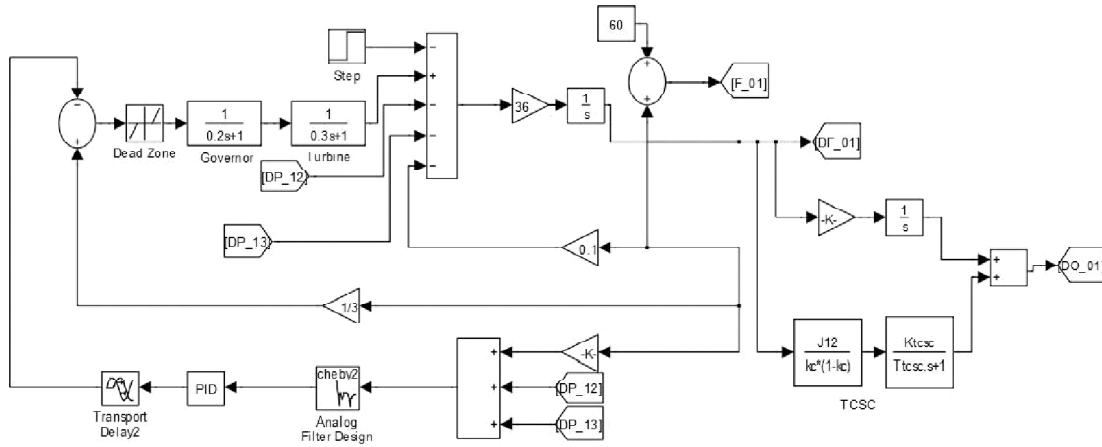

Figure 1: Schematic diagram of Area 1

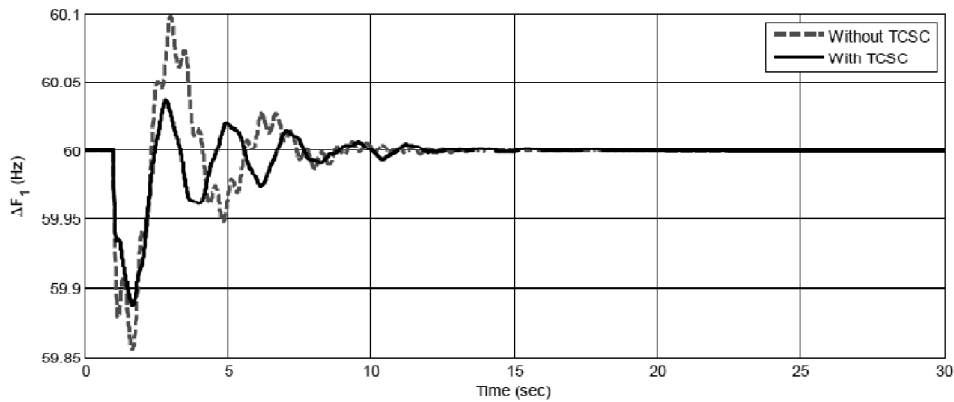

Figure 2: System performance with TCSC and without TCSC

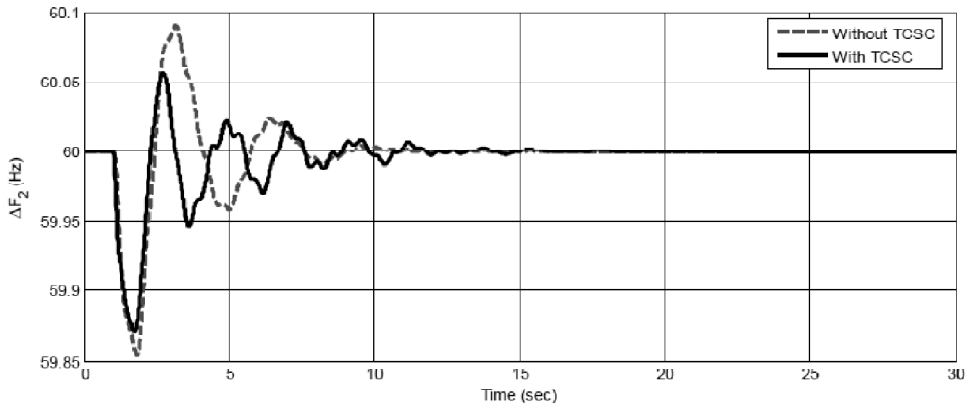

Figure 3: System performance with TCSC and without TCSC

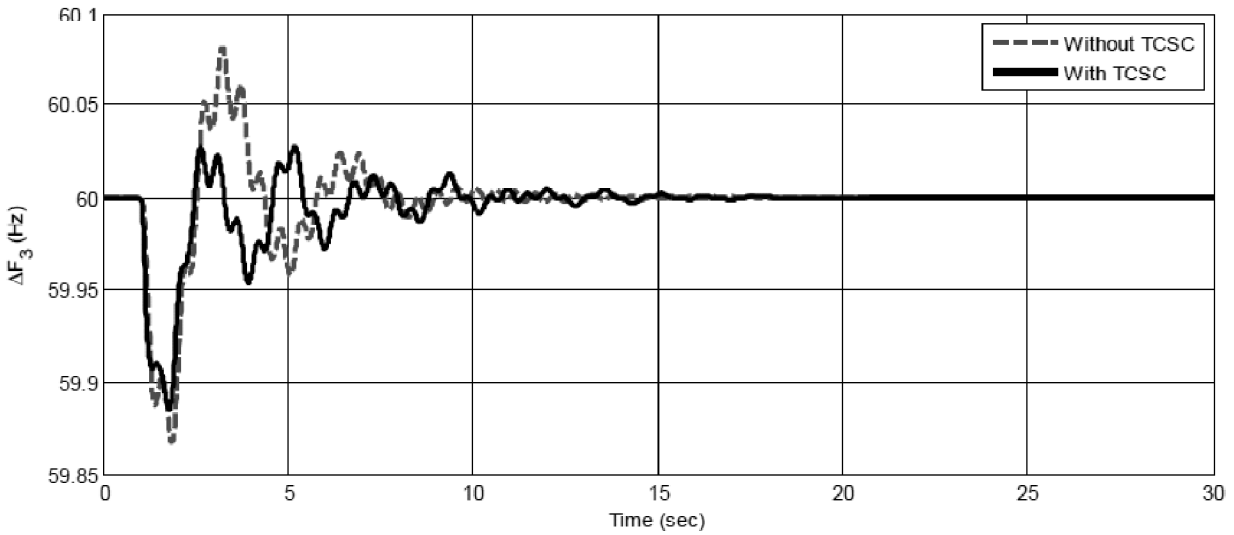

Figure 4: System performance with TCSC and without TCSC

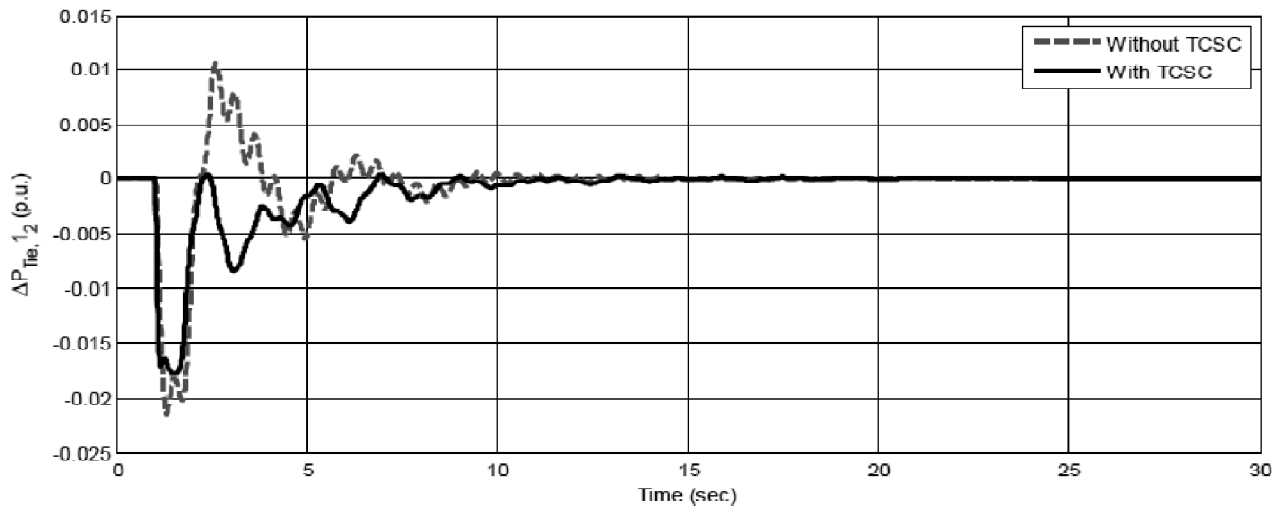

Figure 5: System performance with TCSC and without TCSC

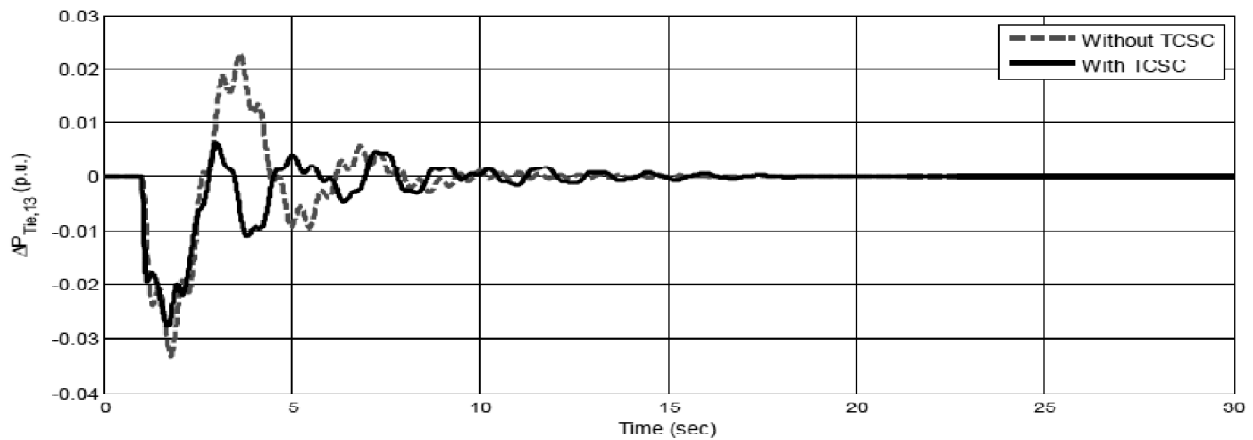

Figure 6: System performance with TCSC and without TCSC

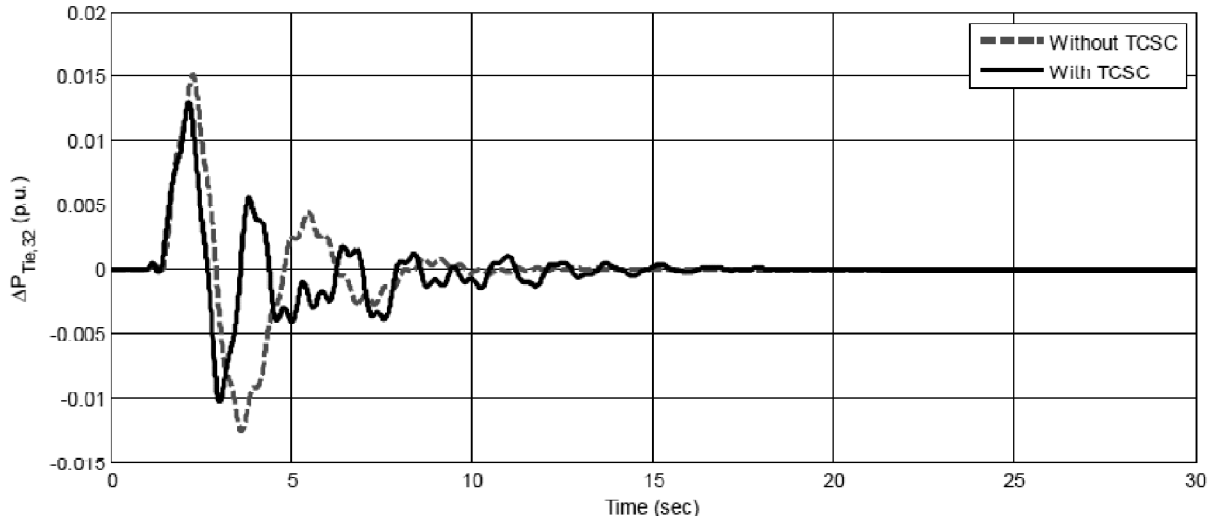

Figure 7: System performance with TCSC and without TCSC

4. CONCLUSION

In this paper modelling of a three area unequal power system is presented. “Particle Swarm Optimization (PSO)” is employed here to obtain the gain values of PID controller. To get realistic scenario and better performance at practical effects called non linearities such as Transport delay as well as Governor Dead band are considered. For the better performance Thyristor Controlled Series Capacitor (TCSC) is employed at area 1 and PID controller is kept as secondary controller in this design. The performance of system comprising of TCSC are compared without TCSC. Finally, by observing the results it can concluded that the system comprising of TCSC shown the better performance than the system not containing TCSC.

APPENDIX

$D1 = 0.1, D2 = 0.2, D3 = 0.15$ [p.u./Hz]; $2H1 = 2H2 = 00.1667, 2H3 = 0.2$ [p.u. s]; $R1 = R3 = 3, R2 = 4$ [Hz/p.u.]; $Tg1 = 0.2, Tg2 = 0.25, Tg3 = 0.3$ [s]; $Tf1 = Tf2 = Tf3 = 0.3$ [s]; $\beta1 = 0.25, \beta2 = 0.3, \beta3 = 0.28$ [p.u./Hz]; $T12 = 0.20, T13 = 0.22, T23 = 0.15$ [p.u./Hz]; $K_{tcsc} = 2.0; T_{tcsc} = 0.02s; \delta_0 = 30$ [Deg.]; $X_t = 10$ [p.u.]”

REFERENCES

- [1] Elgerd, O.I. ‘Electric energy systems theory. an introduction’. 2nd ed., Tata McGraw-Hill, 2007.
- [2] Kundur, P. ‘Power system stability and control’. McGraw-Hill, New York 1994.
- [3] Parmar, K.P.S., Majhi S., Kothari D.P.: ‘Load frequency control of a realistic power system with multi-source power generation’, Int. J. Elect. Power & Energy Sys., 2012, 42. pp. 426-433.
- [4] Hingorani, N. G and Gyugyi, L. ‘Understanding FACTS-Concepts and Technology of Flexible AC. Transmission Systems’, Standard Publishers, IEEE Press, 2000.
- [6] Alberto D. R., Claudio A.C., Victor M. D.: ‘A Study of TCSC Controller Design for Power System. Stability Improvement’, IEEE Transactions On Power Systems, 2003,18(4), pp.1487-1496.
- [8] Kaveh Rahimi and Parviz Famouri ‘Performance Enhancement of Automatic Generation Control for a Multi-Area Power System in the Presence of Communication Delay’, IEEE, 2013.
- [9] R.Roy, S.P.Ghoshal, “A novel crazy swarm optimized economic load dispatch for various types of cost functions”, *Electrical Power and Energy Systems*, vol.30, pp.242-253, 2008.